

Top-of-Pole Mount for 6 Modules (TPM6) for Module Types A, B, C, D, & E

ASSEMBLY INSTRUCTIONS

step-by-step
assembly and installation



Top-of-Pole Mount For 6 Modules (TPM6) For Module Types A, B, C, D, & E

WARNING

Follow the procedures and precautions in these instructions carefully.

About the product

Depending on the module size, the TPM6 is designed to mount on either 4 or 6 inch SCH40/80 galvanized steel pipe (installer supplied).

- 4-inch pipe is used on module types A, B, & C
- 6-inch pipe is used on module types D & E

Pipe size and foundation requirements are based on several factors including the array surface area, maximum design wind speed, exposure category, soil type, steepest expected tilt angle, and above-ground clearance.

For foundation and pipe size recommendations on a specific installation, please:

Visit www.DPWSolar.com and select the TPM online configurator.

Contact us by Phone: 800-260-3792

Send an Email request: info@DPWSolar.com

About these instructions:

- These instructions are intended to be used by individuals with sufficient technical skills for the task. Knowledge and use of hand tools, measuring devices and torque values is also required.
- These instructions include various precautions in the form of Notes, Cautions, and Warnings. These are to assist in the assembly process and/or to draw attention to the fact that certain assembly steps may be dangerous and could cause serious personal injury and/or damage to components. Following the step-by-step procedures, these precautions should minimize the risk of any personal injury or damage to the components while making the installation not only safe but an efficient process.

Required Tools

- 7/16 inch wrench or socket for 1/4 inch module hardware
- 9/16 inch wrench or socket for 3/8 inch hardware
- 1-1/8 inch wrench or socket for 3/4 inch Pivot Bolt hardware
- #2 Square Drive for End Cap Screws
- Torque wrench
- Ratchet wrench
- Ratchet extension bar
- 3 to 6 foot level
- Tape Measure
- Square

TPM6 Types A, B, C, D, & E Main Components

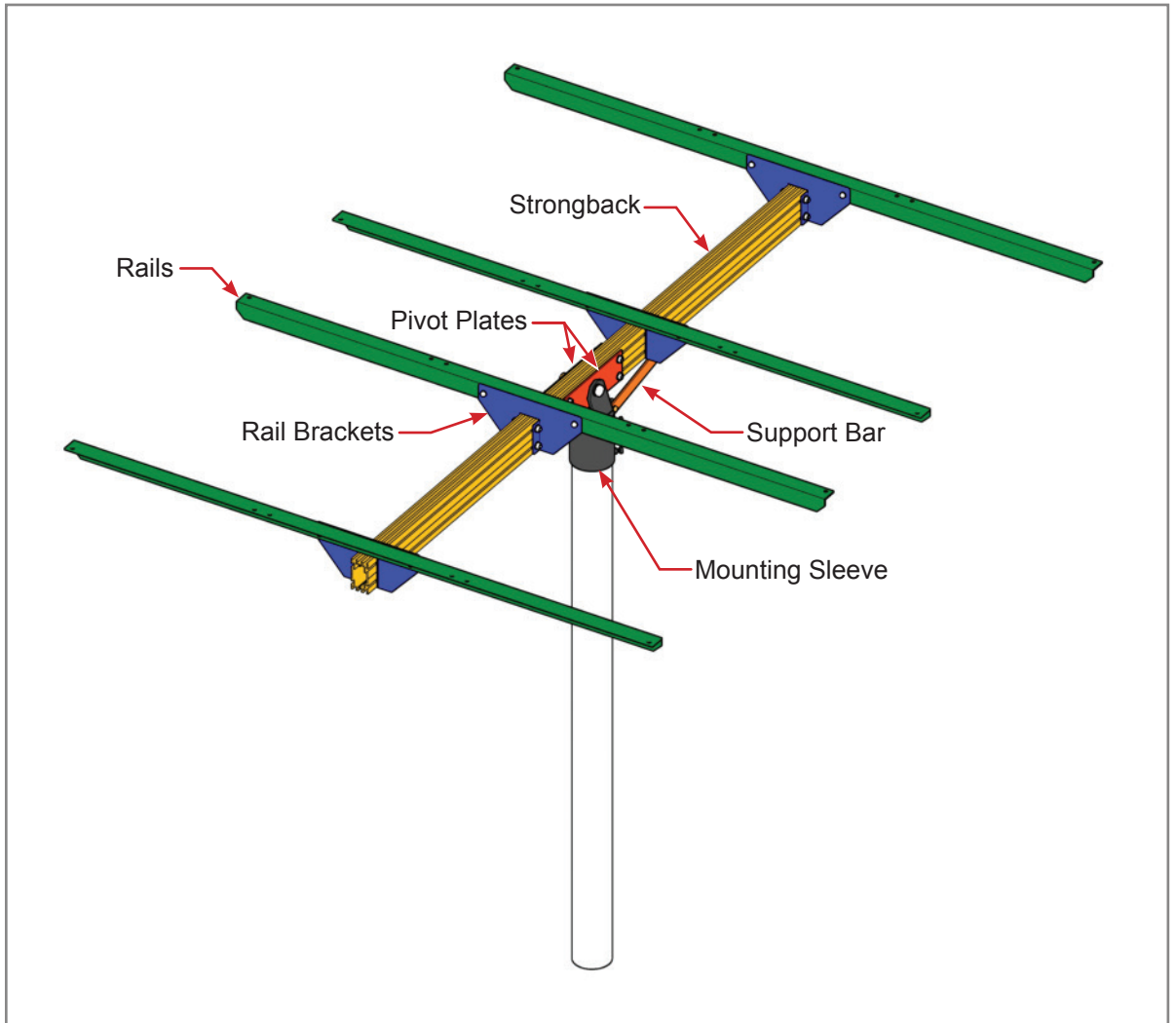

There are just six main components and their attaching hardware.

TPM6 Types A, B, C, D, & E Parts Identification

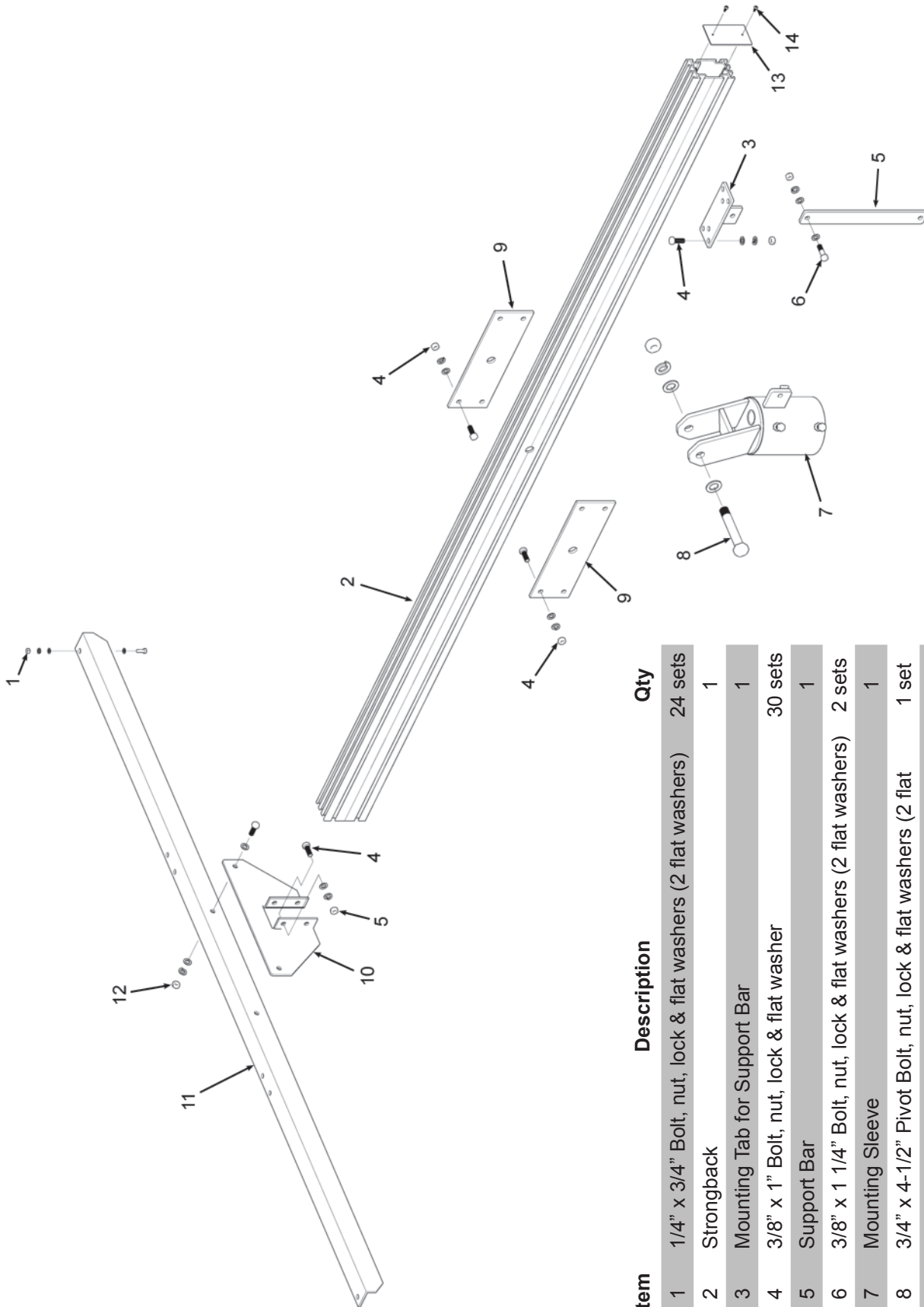

Item	Description	Qty
1	1/4" x 3/4" Bolt, nut, lock & flat washers (2 flat washers)	24 sets
2	Strongback	1
3	Mounting Tab for Support Bar	1
4	3/8" x 1" Bolt, nut, lock & flat washer	30 sets
5	Support Bar	1
6	3/8" x 1 1/4" Bolt, nut, lock & flat washers (2 flat washers)	2 sets
7	Mounting Sleeve	1
8	3/4" x 4-1/2" Pivot Bolt, nut, lock & flat washers (2 flat	1 set
9	Pivot Plate	2
10	Rail Bracket	4
11	Module Rail	4
12	3/8" x 1" Bolt, nut, lock & flat washers (2 flat washers)	8 sets
13	End Cap	2
14	#8 x 1/2" Square Drive Screw	4 sets

1 Attach the Pivot Plates

CAUTION

Use care while working around the structure during assembly. There could be components that create hazards or obstruct free movement causing serious bodily injury. Many are at head/eye level. Move slowly and with care around the work area.

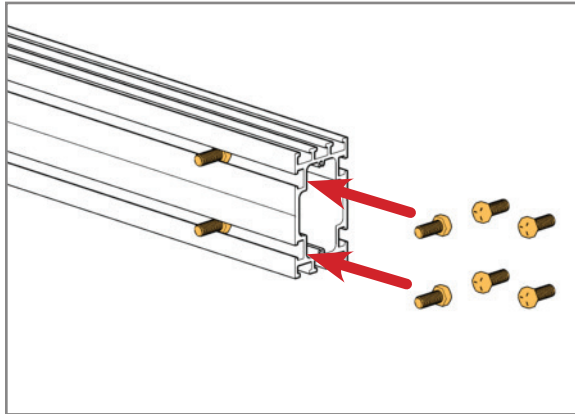

On both sides of the Strongback, insert four 3/8" x 1" Bolts into channels. Arrange the Bolts as shown. Align large center hole of Pivot Plates with Pivot Hole of

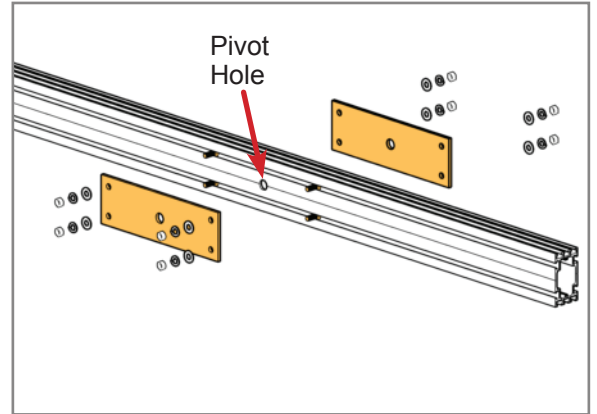

Strongback (inserting Pivot Bolt through the Plates and hole, helps with alignment). Secure with 3/8" Nuts, Lock Washers, & Flat Washers. **Torque to 32-34 ft.-lbs.**

2 Attach the Rail Guides

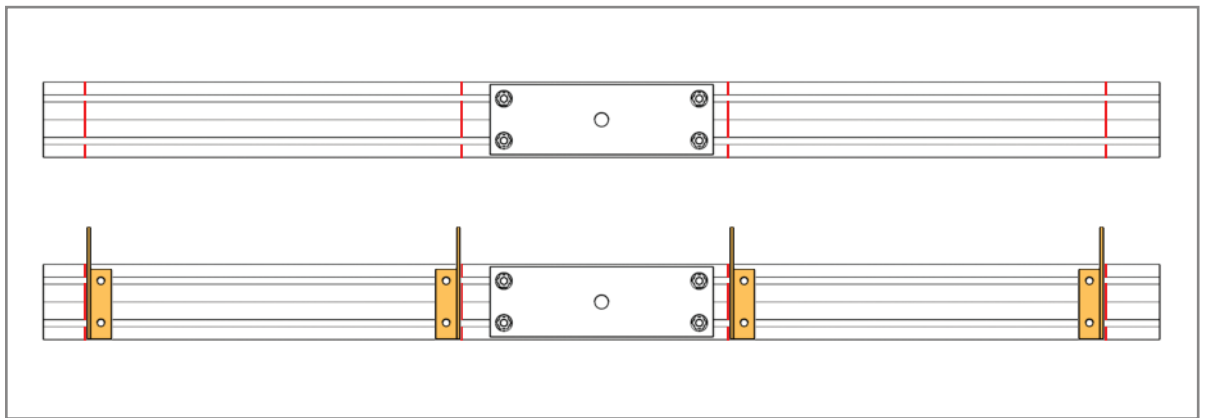

Rail Guide alignment marks (shown in red above for clarity) have been marked-off at the factory. The marks position the span between the Rail Guides to

fit the Modules in use. The bottom image shows the relationship of each of the four Rail Brackets to their respective alignment marks.

NOTE

Temporarily finger-tighten the Rail Brackets to the Strongback while installing. After the PV Modules are installed, re-tighten to specified torque values.

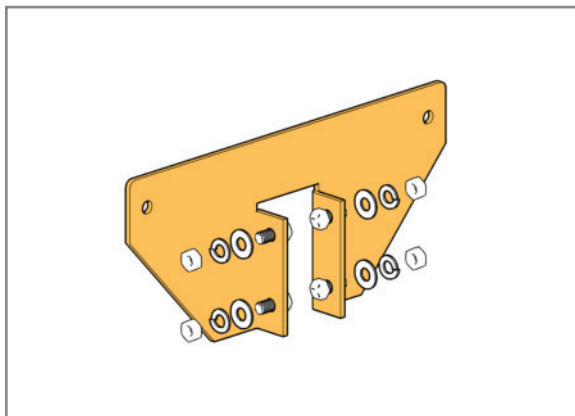

On the four Rail Brackets, loosely install four 3/8" x 1" Bolts, Nuts, Lock Washers, & Flat Washers.

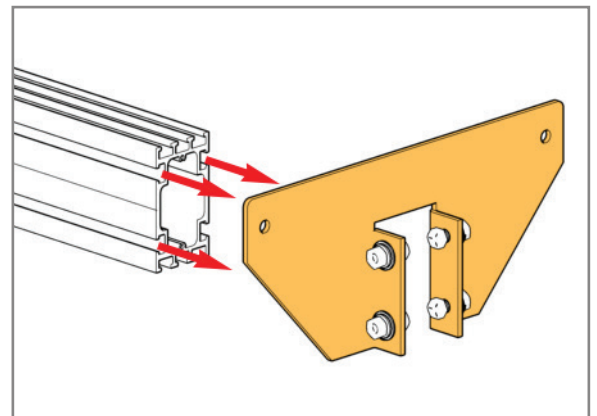

Align Bolts as shown and guide them into the channels of the Strongback. Slide the Rail Brackets to their alignment marks. Tighten and **torque to 32-34 ft.-lbs.**

3 Install the Support Bar

NOTE
Temporarily finger tighten the Support Bar Tab & Support Bar hardware. After the Strongback has been installed, re-tighten to specified torque values.

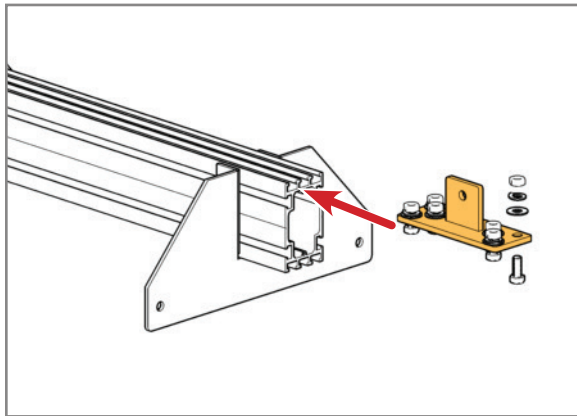

Loosely install the six 3/8" x 1" Bolts, Nuts, Lock Washers, & Flat Washers into the Support Bar Tab. Slide Support Bar Tab onto the Strongback, offsetting

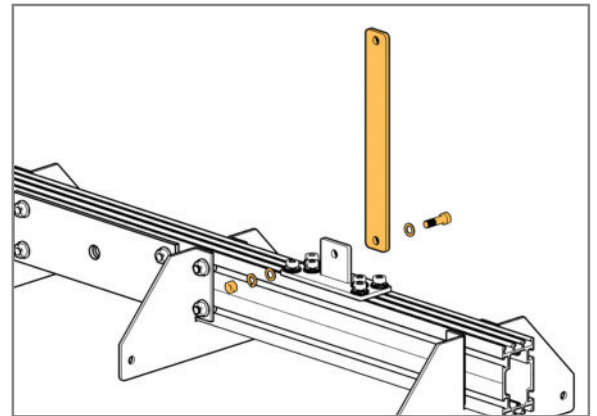

it approximately 16" from the Pivot Hole of the Pivot Plates. Attach the Support Bar using 3/8" x 1-1/4" Bolt, two Flat Washers, Lock Washer and 3/8" Nut.

4 Install the End Caps

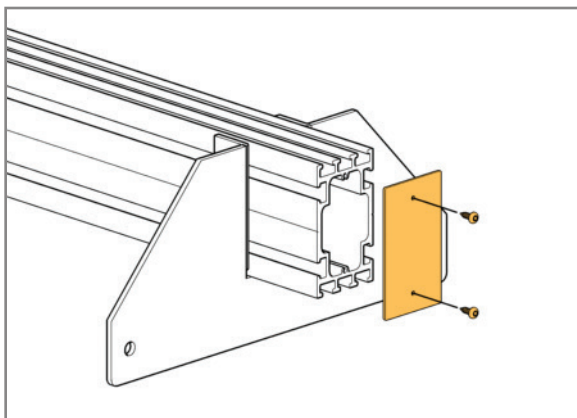

Install one End Cap on both ends of Strongback. Secure with two #8-15 x 1/2" Square Drive Screws.

5 Install the Mounting Sleeve on Vertical Pipe (Showing 4-inch and 6-inch Pipe Versions)

NOTE
Module Types A,B, & C use a 4-inch pipe and a Mounting Sleeve with *three* 3/8"-16 Set Bolts.
Module Types D & E use a 6-inch pipe and a Mounting Sleeve with *four* 1/2"-13 Set Bolts.
Torque Settings:
3/8"-16 32-34 ft-lbs.
1/2"-13 55-60 ft-lbs.

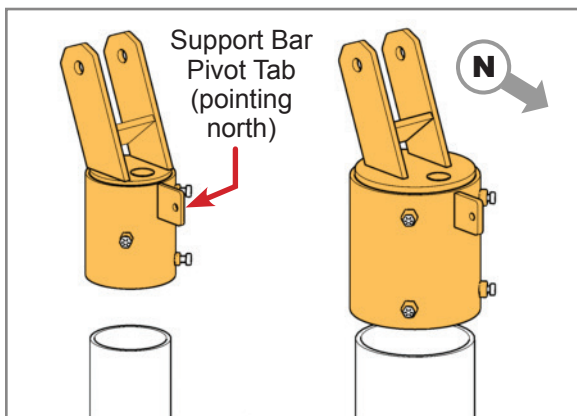

Slip the Mounting Sleeve on top of Mounting Pole allowing it slide down and bottom out on the Pole. Rotate the Mounting Sleeve so that the Support Bar

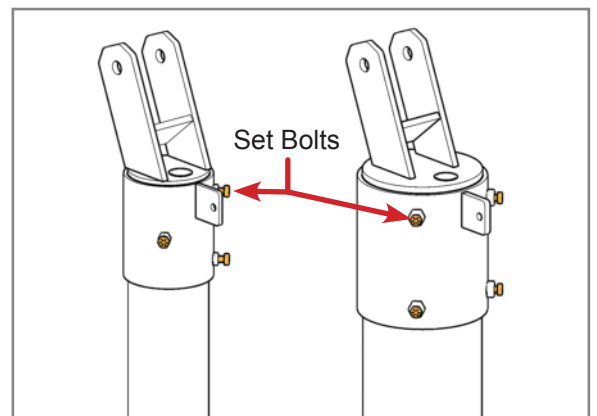

Pivot Tab is pointing north and the Strongback Vertical Towers are leaning south. Tighten and torque all Set Bolts using the **appropriate values listed at left.**

6 Installing the Strongback

CAUTION

This is a two person activity. The Strongback must be held in place by one person while the second person aligns it and secures it to the Mounting Sleeve using the Pivot Bolt and Support Bar. Failure to do so could lead to serious personal injury.

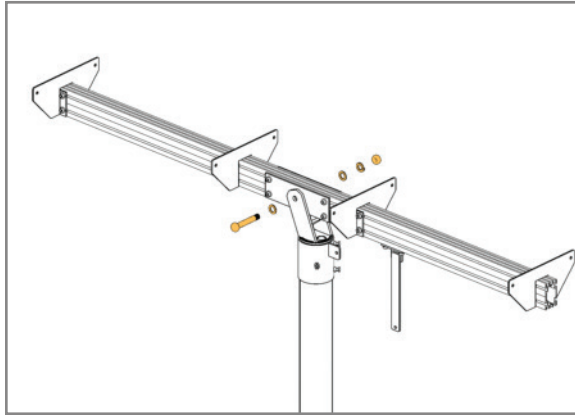

Secure Strongback to Mounting Sleeve with Pivot Bolt, two Flat Washers, Lock Washer and Nut. For now, finger tighten to allow movement during the next step.

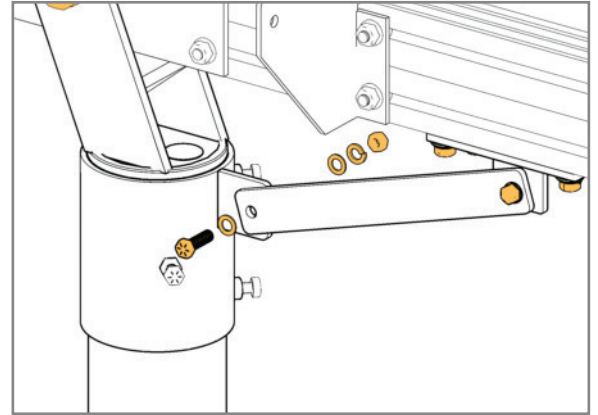

Secure Support Bar to Mounting Sleeve with 3/8" x 1-1/4" Bolt, two Flat Washers, Lock Washer and Nut. Securely tighten hardware to hold structure in place while continuing assembly.

NOTE

Although this system offers variable elevation set points, for ease of assembly, set the angle to 0-degrees. Optimum tilt setting of the rack will take place later in these instructions.

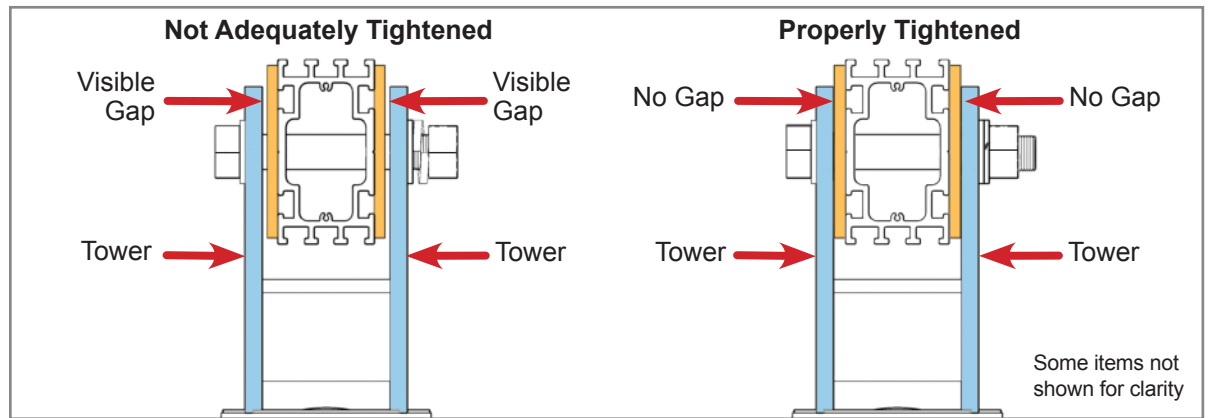

Tighten Pivot Bolt closing any visible gaps between the Pivot Plates and the Mounting Sleeve Towers. **Torque to 125-150 ft.-lbs.**

7 Install the Module Rails

CAUTION

This is a two person activity. Module Rails are unstable before they are secured to the Rail Brackets.

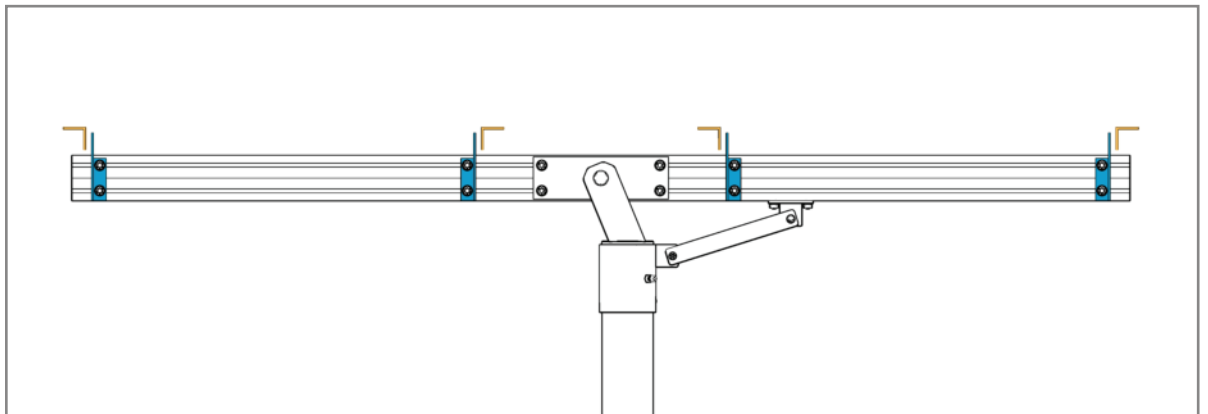

The Module Rails must be oriented and installed to the Rail Brackets as shown above.

7 Install the Module Rails (continued)

NOTE

Finger-tighten the Module Rails to the Rail Brackets while installing. After the PV Modules are installed, re-tighten to specified torque values.

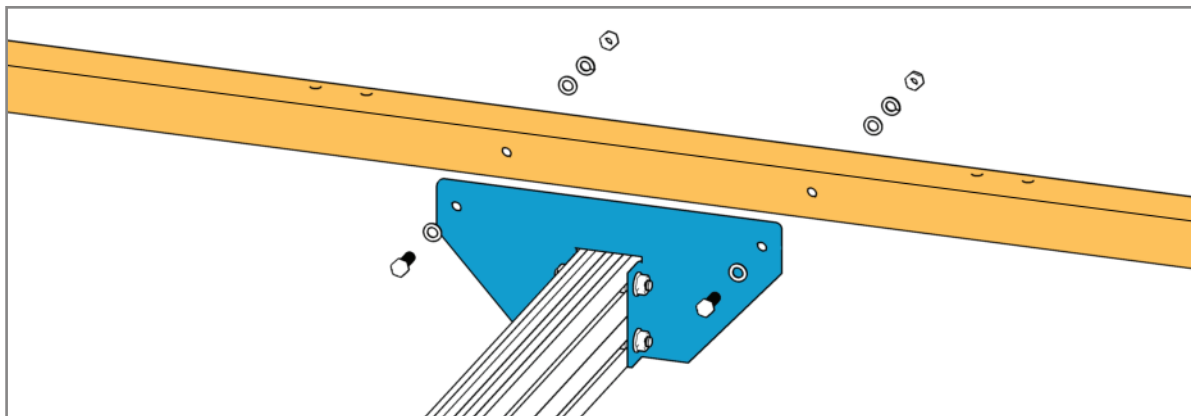

Secure Module Rails to Rail Brackets with 3/8" x 1" Bolt, two Flat Washers, Lock Washer and Nut.

8 Installing Modules

CAUTION

This is a two person activity. PV Modules are heavy and unstable before they are fully secured to the Module Rails. PV Modules must be held in place by one person while the second person aligns and secures them to the Module Rails. Failure to do so could lead to serious personal injury and damaged components.

NOTE

Finger-tighten the Modules to the Rails while installing to allow alignment and spacing of the Modules. Re-tighten to specified values after all Modules are installed.

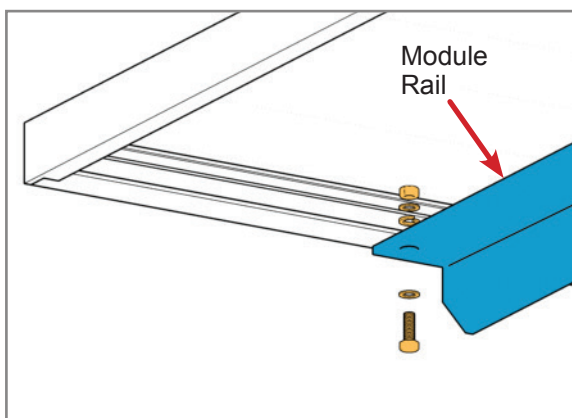

Secure Modules at each of their four attachment points with 1/4" x 3/4" Bolt, two Flat Washers, Lock Washer, and Nut.

9 Now Return and Tighten Mounting Hardware

CAUTION

Be certain to re-tighten all Rail Bracket, Module Rail and PV Module mounting hardware and torque to the specified values. Failure to do so could lead to structural failure, damaged components and/or serious personal injury.

- A. Return and tighten each set of the 3/8" mounting hardware, securing the *Module Rails* to the *Rail Brackets*. **Torque all at 32-34 ft.-lbs.**
- B. Return and tighten each set of 1/4" mounting hardware, securing the *PV Modules* to the *Module Rails*. **Torque all at 6-8 ft.-lbs.**
- C. Return and tighten each of the 3/8" Flange Nuts, securing the *Rail Brackets* to the *Strongback*. **Torque each Flange Nut to 32-34 ft.-lbs.**

10 Adjust the Array Tilt Angle

WARNING

Do not attempt to remove the Pivot Bolt during tilt adjustments! Removal could lead to serious personal injury or death. Adjustments are made with the Pivot Bolt hardware loosened but in place.

CAUTION

This is a two person activity. As the hardware is loosened, the rack is heavy and unstable. The rack must be held in place by one person while the second person loosens the hardware and then re-installs and tightens the hardware back in place. Failure to do so could lead to serious personal injury and damaged components.

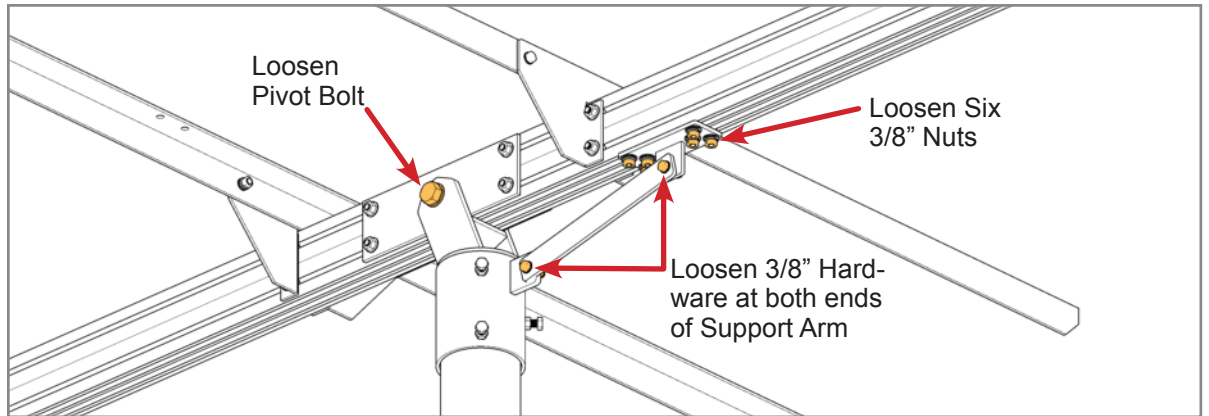

Two person activity.

1. While the first person holds the south edge of rack, the second person:
 - Loosens the Pivot Bolt.
 - Loosens the six 3/8" Nuts securing the Mounting Tab to the underside of the Strongback.
 - Loosens the 3/8" hardware at both ends of the Support Arm.
2. The first person (holding the edge of the rack) now tilts the rack to the desired elevation angle.
3. The second person now re-tightens:
 - The 3/8" Nuts securing the Mounting Tab to the underside of the Strongback. **Torque to 32-34 ft.-lbs.**
 - The 3/8" hardware at both ends of the Support Bar. **Torque to 32-34 ft.-lbs.**
 - The Pivot Bolt. The Pivot Bolt cannot be left loose - the Mounting Sleeve Vertical Towers must be firmly clamped to the sides of the Strongback eliminating any gaps between the Vertical Towers and the Strongback. **Torque to 125-150 ft.-lbs.**

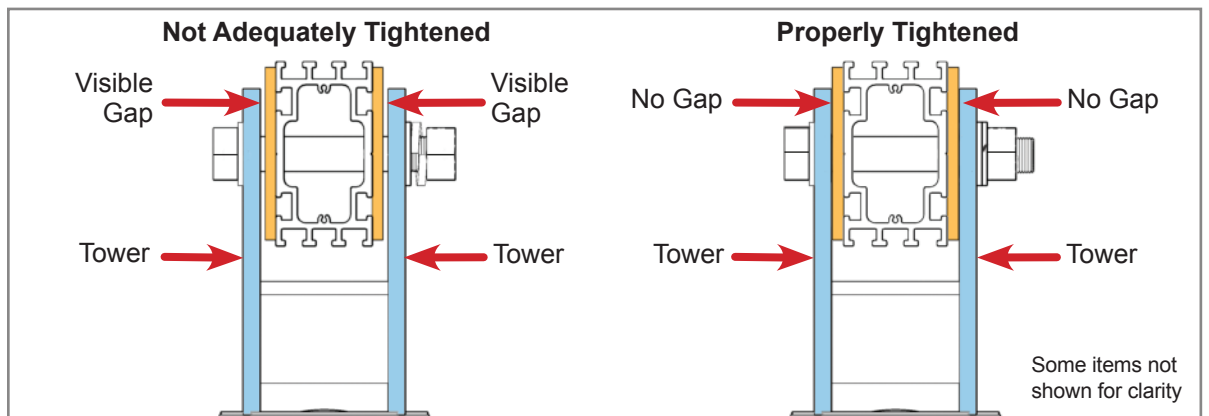



Corporate Headquarters
660 Beta Drive
Mayfield Village, OH 44143

Albuquerque Office
1700 Louisiana Ave., Suite 130
Albuquerque, NM 87110

Telephone: 440.461.5200
Web Site: www.preformed.com
E-mail: inquiries@preformed.com

Telephone: 800.260.3792
Fax: 505.889.3548
Web Site: www.DPWSolar.com
E-mail: info@dpwsolar.com