

**COYOTE® PUP CLOSURE  
 FOR UNDERGROUND, AERIAL, AND BURIED SPLICES  
 6.0" x 17"  
 (152.4 mm x 431.8 mm)**

Be sure to read and completely understand this procedure before applying product. Be sure to select the proper PREFORMED™ product before application.

CONTENTS	PAGE	CONTENTS	PAGE
1. NOMENCLATURE .....	2,3,4	12. INSTALLING FIBERS INTO TRANSPORT TUBES AND SECURING TO TRANSITION COMPARTMENT .....	11,12
2. DESCRIPTION AND CLOSURE CAPACITIES .....	4	13. SECURING TRANSPORT TUBES AND ROUTING FIBERS IN SPLICE TRAYS .....	12-14
3. END PLATE CONFIGURATIONS.....	4	14. ROUTING LOOSE BUFFER TUBE CABLE.....	14-16
4. CABLE PREPARATION-LOCK-TAPE SEALANT APPLICATION .....	5,6	15. INSTALLING CLOSURE SHELLS .....	16
5. INTERNAL BOND PROCEDURE.....	6	16. EXTERNAL BOND PROCEDURE .....	16,17
6. END PLATE PREPARATION.....	7	17. STRAND MOUNT PROCEDURE .....	17
7. END PLATE ASSEMBLY .....	7,8	18. MANHOLE SUPPORT BRACKET KIT INSTALLATION.....	18
8. UNITUBE PREPARATION.....	9	19. BURIED INSTALLATION.....	18
9. INSTALLING TRANSITION COMPARTMENT .....	9	20. MAINTENANCE PROCEDURES .....	18
10. SECURING UNITUBE CABLE IN THE TRANSITION COMPARTMENT .....	10	21. SAFETY CONSIDERATIONS.....	18
11. ROUTING AND STORING FIBERS IN THE TRANSITION COMPARTMENT .....	10,11		

# 1.00 NOMENCLATURE

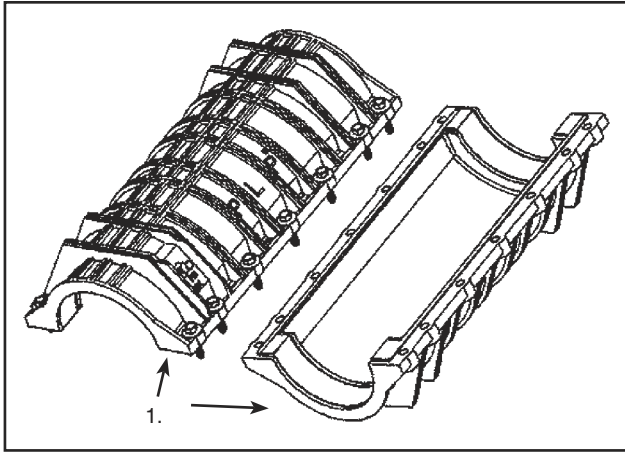

**FIGURE 1 - SHELL KIT**

- 1. Two COYOTE® PUP Closure shell halves, neoprene gasket is applied at factory.

Catalog Number	Dimensions (mm)
80805795	6.0" x 17" (152.4 x 431.8)

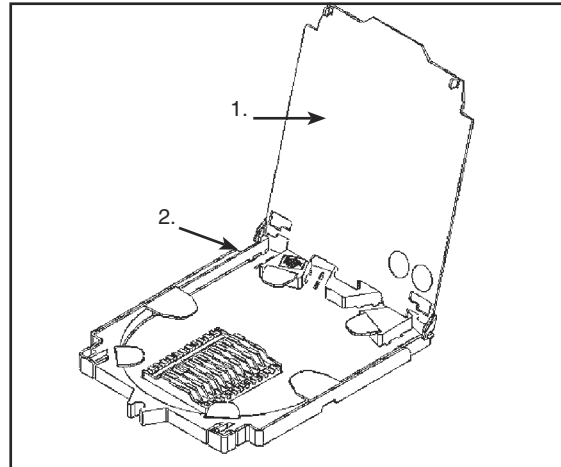

**FIGURE 2 - SPLICE TRAY KIT**

- 1. Cover
- 2. Tray
- 3. Splice Count Label (not shown)
- 4. Tie Wraps (not shown)
- 5. Felt Strips (not shown)

Catalog No.	Description	Splice Capacity
80806033	12-Count Single Fiber with Elastomer Block	12
80807701	Low Profile Tray	12
80807114	Ribbon	72

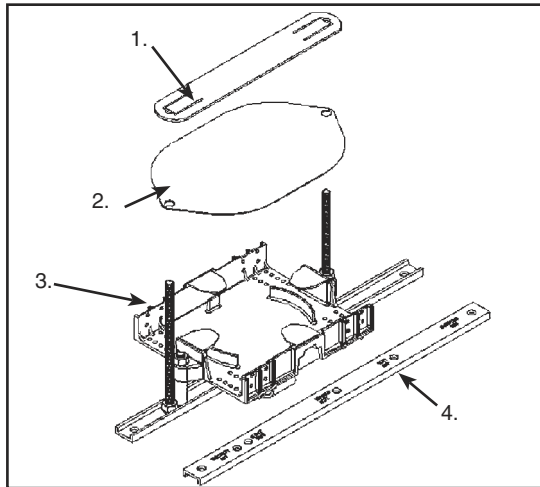

**FIGURE 3 - UNITUBE TRANSITION COMPARTMENT KIT**

- 1. Splice Tray Hold Down Strap
- 2. Cover
- 3. Transition Compartment
- 4. Torque Bar

Catalog Number	Description (mm)
80805775	6.0" x 17" (152.4 x 431.8) Unitube Transition Compartment Kit

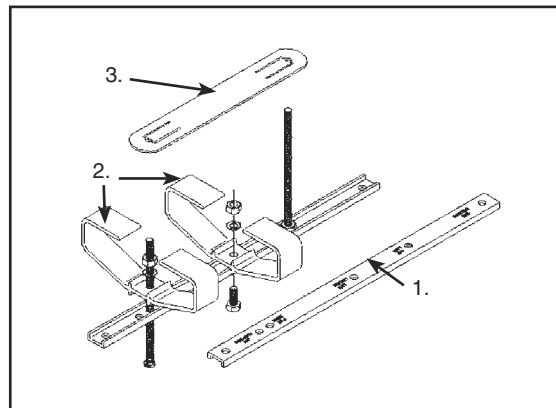

**FIGURE 4 - LOOSE BUFFER TUBE STORAGE KIT**

- 1. Torque Bar
- 2. Retainer Brackets
- 3. Splice Tray Hold Down Strap

Catalog Number	Description
80805771	6.0" x 17" (152.4 x 431.8) Loose Buffer Tube Storage Kit

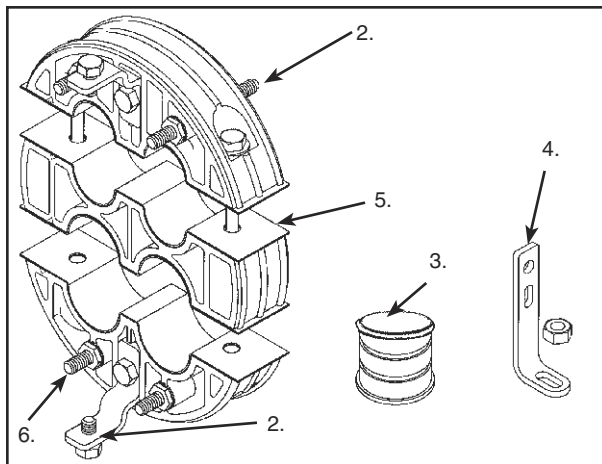

**FIGURE 5 - THREE-SECTION  
FOUR PORT END PLATE KITS**

1. End Plate Sections
2. Torque Bar Brackets (2)
3. Plugs (5)
4. "L" Brackets (2)
5. LOCK-TAPE™ Sealant (factory-applied)
6. Internal Ground Inserts (6; factory-installed)
7. COYOTE Cable Mea-SURE™ Tape (not shown)

Catalog Number	Description
80805105	Three-Section End Plate Kit
80805739	Four-Section End Plate Kit

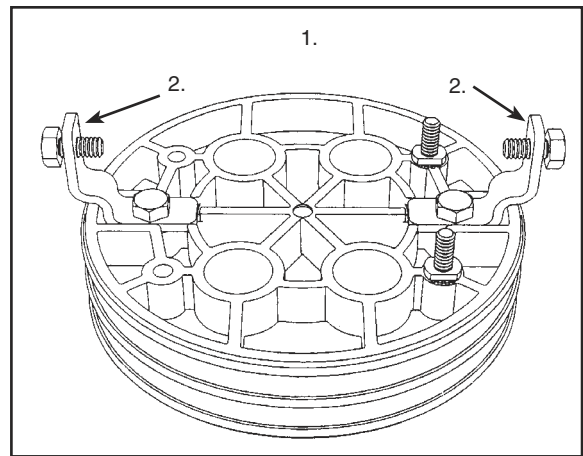

**FIGURE 6 - BLANK END PLATE KIT**

1. End Plate
2. Torque Bar Brackets (2)

Catalog Number	Description
80805260	Blank End Plate Kit

### ACCESSORY KITS

Catalog Number	Description
8003285	Color-Coded Transport Tube Kit (6 per kit)
80805293	Transport Tube Kit (6 per kit)
80805107	Strength Member Bracket Kit (2 per kit)
80805431	Long Strength Member Bracket Kit (2 per kit)
80806037	3/4" End Plate Plug Kit (2 per kit)
80806180	7/8" End Plate Plug Kit (2 per kit)
80806038	1" End Plate Plug Kit (2 per kit)
80806181	1-1/4" End Plate Plug Kit (2 per kit)
8003280	Transition Tube Kit
8003281	External Bond Clip Kit (2 per kit)
80805286	Bracket Adaptor Kit for AT&T Bond Connector (4 per kit)
8003325	Adjustable Aerial Hanger Bracket Kit
8003289	Future Cable Entry Port/Cable Installation Kit - .56" (14.2 mm) max. cable diameter 7/8" Port
8003407	1" Future Cable Entry Port
8003409	1-1/4" Future Cable Port Entry Port
8003291	Future Cable Installation Kit for 1" & 1-1/4" Entry Ports
80803448	Moisture Blocking Sealant Kit (B Sealant, 3 oz.)
80805238	C-Cement (1 oz. tube)
8003322	Internal Ground Kit (.27-.31 cables)
8003360	Exterior Bond Braid Kit
8003279	Manhole Support Bracket
8003372	Vertical Mounting Bracket

**1.01** The COYOTE® PUP Closure contains everything needed for installation except hand tools, vinyl tape, filled cable cleaning fluid, and C-Cement.

**1.02 Tools Needed:**

- 1/2" socket\*
- 7/16" socket\*
- 3/8" socket/Can wrench
- Snips
- Ratchet Wrench\*
- Torque Wrench (capable of reading 150 inch lbs.)\*
- Fiber optic cable opening tools

\*Available from Preformed Line Products

**2.00 DESCRIPTION AND CLOSURE CAPACITIES**

**2.01** For Safety Considerations, refer to Section 21.00 of this procedure.

**2.02** The COYOTE PUP Closure organizes, distributes and protects all types of fiber optic cable with a water and air tight seal.

**2.03** The COYOTE PUP Closure accommodates the following splice tray and splice connectors (Table 1):

Splice Tray Catalog No.	Description	Useable Connectors	Splice Capacity per Tray	No. of Trays per Closure	Closure Splice Capacity
80806033	12-Count Single Fiber Tray	Single Fusion Single Mechanical	12	4	48
80807701	12-Count Single Fiber Tray	Single Fusion	12	6	72
80807114	Ribbon Tray	Mass Fusion	72	2	144

**TABLE 1**

**3.00 END PLATE CONFIGURATIONS**

**3.01** Each End Plate may accept six cables; three cables in the top seam and three in the bottom seam. Arrows indicate ground inserts for each port. (Figure 7)

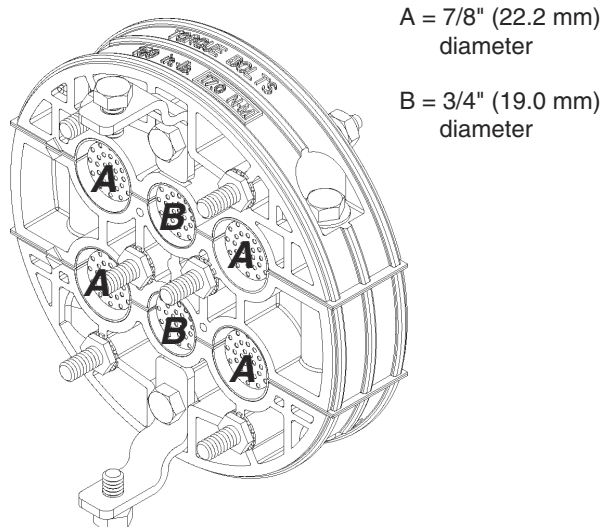

**FIGURE 7 - DIAGRAM OF END PLATE**

**3.02** See Figure 8 for hardware that can be used with the Three-Section End Plate.

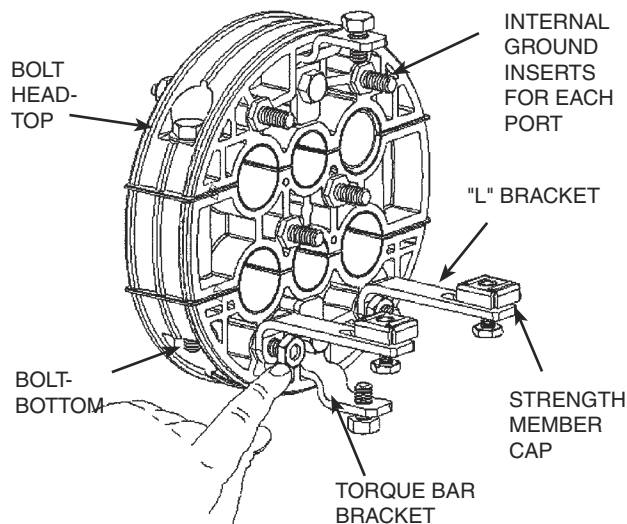

**FIGURE 8 - END PLATE HARDWARE**

#### 4.00 CABLE PREPARATION—LOCK-TAPE SEALANT APPLICATION

**NOTE:** For OPGW application, see procedure entitled, “OPGW Cable and End Plate Preparation for COYOTE® Closure” (SP2849).

**4.01** Cable sheath opening measurements are 128" (3250 mm) for continuous loop/express applications, and 64" (1620 mm) for cut cable.

**NOTE:** The COYOTE PUP Closure is designed for main cables to enter the bottom outside cable ports and for branch cables to enter the bottom middle and upper cable ports in the End Plate.

**PLP TIP:** Where irregular cable ends exist, measure from the shortest cable to establish End Plate location.

**4.02** The color-coded COYOTE Cable Measure Tape is used to determine the number of half-lapped layers of LOCK-TAPE Sealant required to seal the cable in the End Plate. The orange-colored end is used to measure cables entering the 7/8" (22.2 mm) diameter ports while the blue-colored end measures cables entering the 3/4" (19.0 mm) diameter ports. The back of the Measure Tape is used to check whether the LOCK-TAPE Sealant wrap is the proper diameter to ensure a water and air tight seal. (Figure 9)

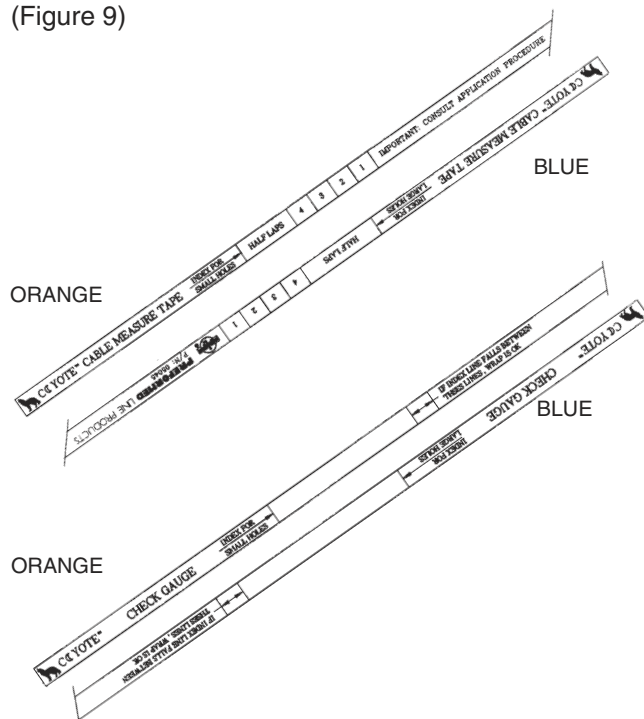

**FIGURE 9 - COYOTE CABLE MEASURE TAPE**

**4.03** TO USE COYOTE CABLE MEASURE TAPE:

- Wrap the **correct end** of COYOTE Cable Measure Tape around cable where it will enter the End Plate.
- If the index line falls directly between two numbers use the higher number.
- The number on the COYOTE Cable Measure Tape indicates the number of half-lapped layers of LOCK-TAPE Sealant to be applied around the cable. (Figure 10)

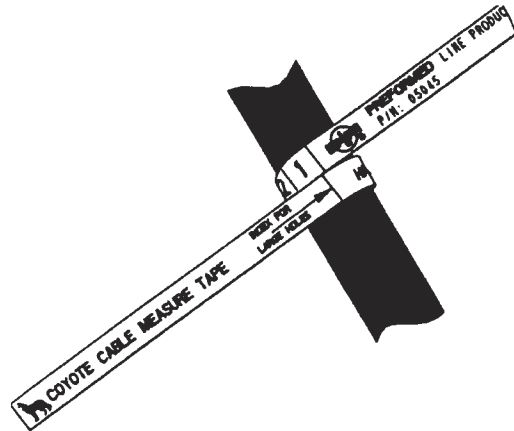

**FIGURE 10 - MEASURING CABLE -- BE SURE TO USE CORRECT END OF CABLE MEASURE TAPE**

**4.04** Using the provided Emery Cloth, thoroughly scuff the cable sheath for 5" (127.0 mm) from measured opening. Always scuff **around** the cable, never lengthwise.

**4.05** Coat the scuffed area with C-Cement and allow to dry. It is important that the C-Cement dries to a tacky base before LOCK-TAPE Sealant is applied.

**PLP TIP:** Use removed LOCK-TAPE Sealant backing from Step 4.06 to dry and remove excess C-Cement applied to cable.

**4.06** Remove backing from LOCK-TAPE Sealant and wrap LOCK-TAPE Sealant onto the cable with the black side up. Stretch the 1" (25.4 mm) LOCK-TAPE Sealant to a width of 7/8" (22.2 mm). (Figure 11) Apply the required numbers of half-lapped layers of LOCK-TAPE Sealant, as indicated on the Cable Measure Tape, to the area coated with C-Cement. (Figure 12)

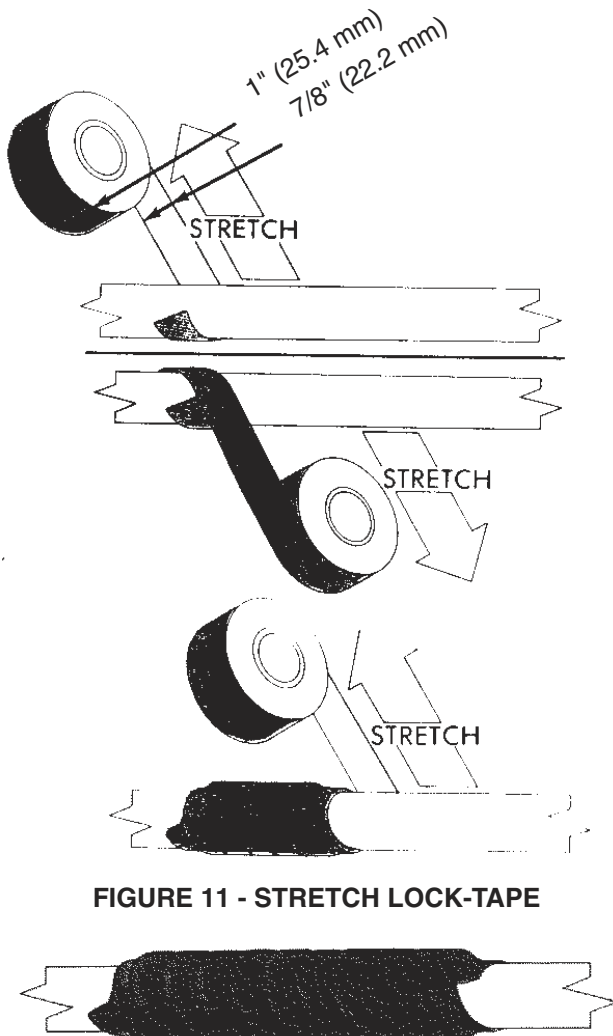

**FIGURE 11 - STRETCH LOCK-TAPE**

**FIGURE 12 - APPLIED LOCK-TAPE**

**4.07** To check LOCK-TAPE Sealant application, wrap the proper end of the COYOTE Cable Measure Tape check gauge around the applied LOCK-TAPE Sealant. If the measurement line falls outside of the index lines of the check gauge, LOCK-TAPE Sealant must be reapplied. It is acceptable to reapply the original LOCK-TAPE Sealant. (Figure 13)

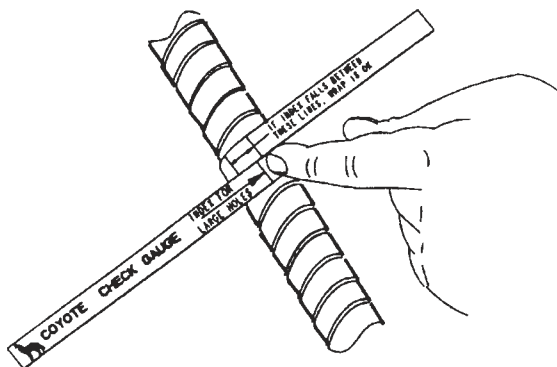

**FIGURE 13 - CHECK GAUGE**

**4.08** To protect LOCK-TAPE Sealant from cable grease, cover the LOCK-TAPE Sealant with vinyl tape.

**NOTE:** If strength members are to be secured, leave 4-5" (101-127 mm) of metallic or non-metallic strength members exposed from the sheath opening.

**4.09** Open and clean cable according to accepted company practices.

**5.00 INTERNAL BOND PROCEDURE**

**5.01** Bond cable according to accepted company practices. Use the slot on the "L" bracket to attach most bond connectors, as outlined in Section 8.00. (Figure 14)

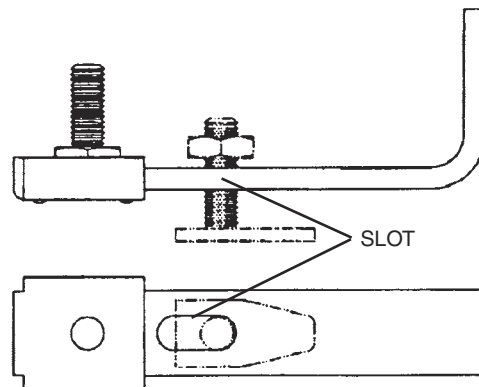

**FIGURE 14A - SLOT IN "L" BRACKET**

**PLP TIP:** A long "L" bracket is available (Catalog #80805431) for bonded loose buffer tube cable with a dielectric central strength member.

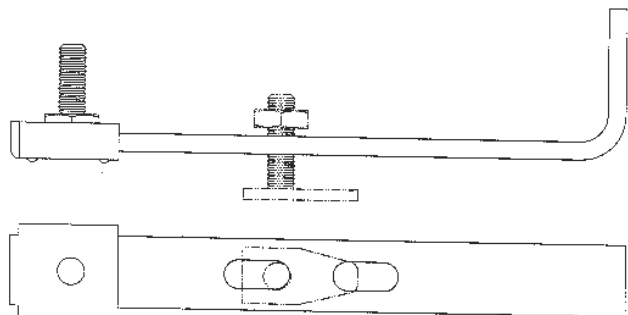

**FIGURE 14B - LONG "L" BRACKET**

## 6.00 END PLATE PREPARATION

**6.01** Disassemble the End Plate by removing the two long bolts holding the three End Plate sections together. Remove the packaging plugs.

**6.02** Refer to Table 2 for the measurement of sheath to extend beyond the inside of the End Plate for the type of cable and bond connector being used. For all non-metallic cables the sheath will extend 3/4" (19.0 mm) inside the End Plate.

Cable Positions In COYOTE Closure End Plate		
Cable Type	If using Bond Connectors	Length of Sheath Inside End Plate (mm)
Dielectric		3/4" (19.0)
Metallic	RAYCHEM*	1-1/4" (31.8)
	AT&T*	Total 1-3/8" (34.7) = 5/8" (15.7) shield + 3/4" (19.0) sheath

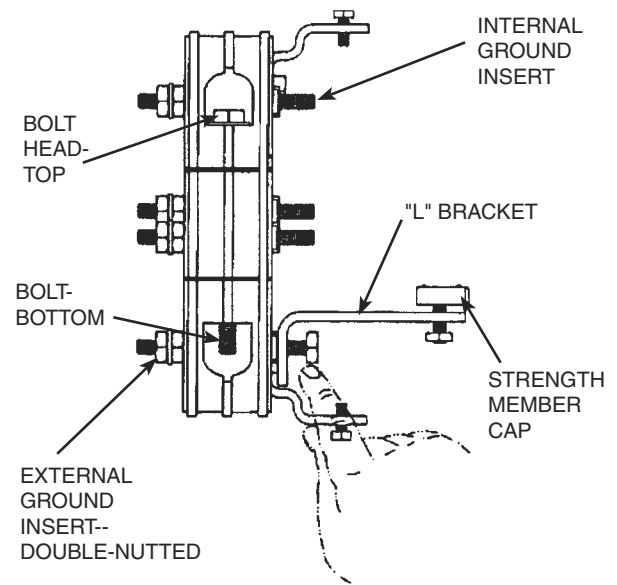
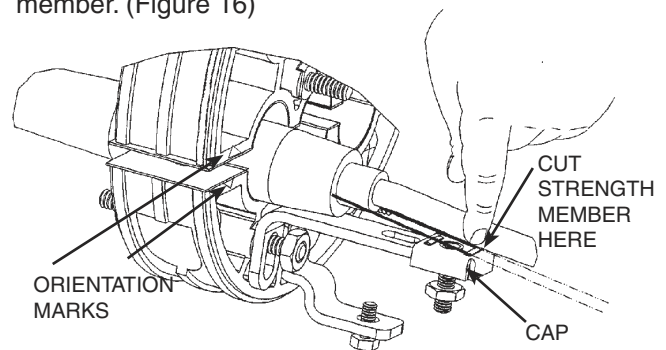

**FIGURE 15B - ATTACH "L" BRACKET--SIDE VIEW**

**7.02** Remove the protective vinyl tape applied to LOCK-TAPE Sealant in Paragraph 4.08.

**7.03** Place the cable into the End Plate as close to the assembly location as possible. Mark it 1/4-1/2" (6.4-12.7 mm) from the outside surface of the End Plate. Apply vinyl tape over the remaining LOCK-TAPE Sealant. **Do not apply vinyl tape in the seal area.**

**7.04** Use the strength member cap on the "L" bracket as a guide for trimming the strength member. (Figure 16)



**FIGURE 16 - CAP AS TRIMMING GAUGE**

**7.05** Remove cable from the End Plate port(s) and apply C-Cement along the edge of all End Plate ports. Make sure C-Cement is dry before continuing. The End Plate center section is illustrated in Figure 17.

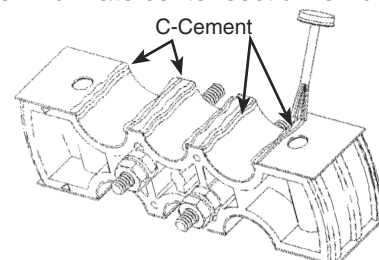

**FIGURE 17 - APPLY C-CEMENT**

## 7.00 END PLATE ASSEMBLY

**7.01** Loosely attach "L" brackets to the ground insert on the inside of the End Plate adjacent to the cable ports being used with the nut provided. (Figure 15 A & B)

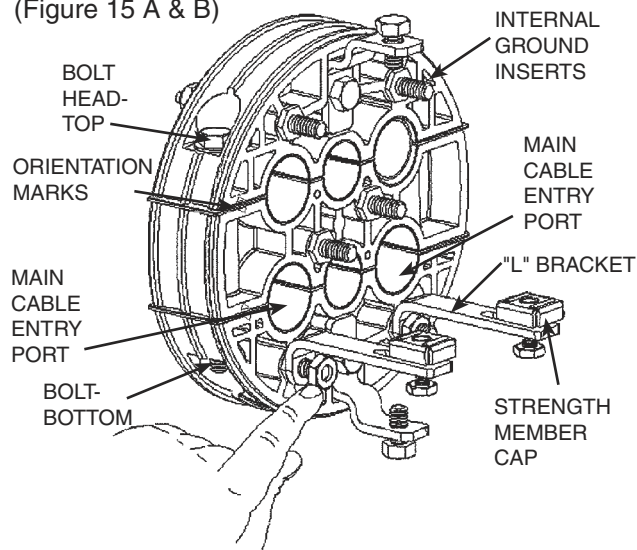

**FIGURE 15A - ATTACH "L" BRACKET--FRONTAL VIEW**

**7.06** Lay prepared cable and appropriate plugs into ports and loosely tighten all three sections of End Plate. Use care that no grease from the cable contacts the LOCK-TAPE Sealant on the End Plate ports. (Figure 18)

**PLP TIP:** Use orientation marks on End Plate as alignment guide. (See Figures 18 & 19)

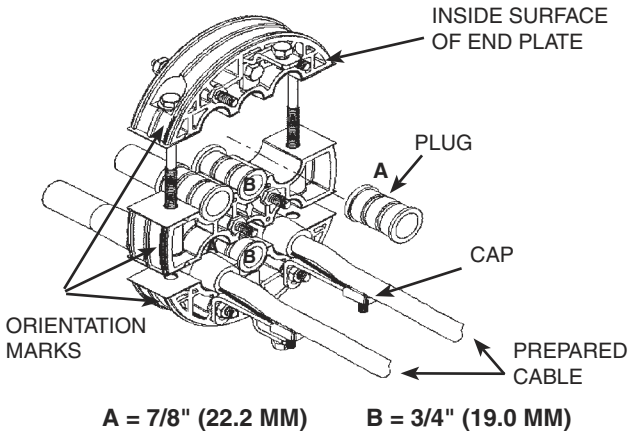

**FIGURE 18 - INSTALLED CABLE AND PLUGS**

**7.07** Future cable entry ports cannot be added once End Plate assembly is complete. Therefore, when using future cable entry ports, insert ports at this time. Future cable entry ports will fit in only the "A", or 7/8" ports. Also see the Application Procedure accompanying the Future Cable Entry Port Kit, #8003289. (Figure 19)

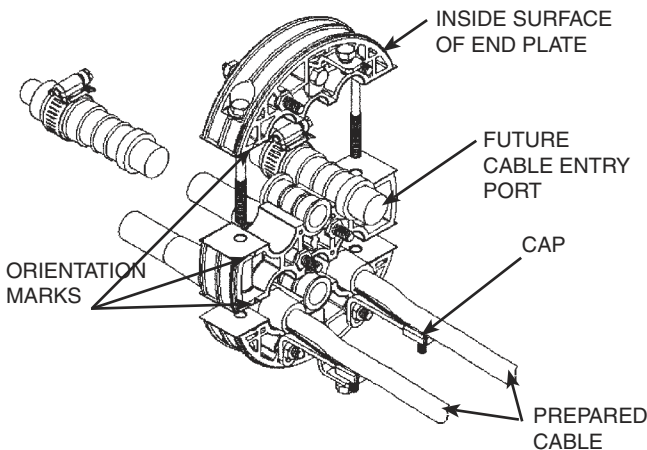

**FIGURE 19 - INSTALLED FUTURE CABLE ENTRY PORTS**

**7.08** Slide strength members under cap and tighten. Tighten "L" bracket. (Figure 20)

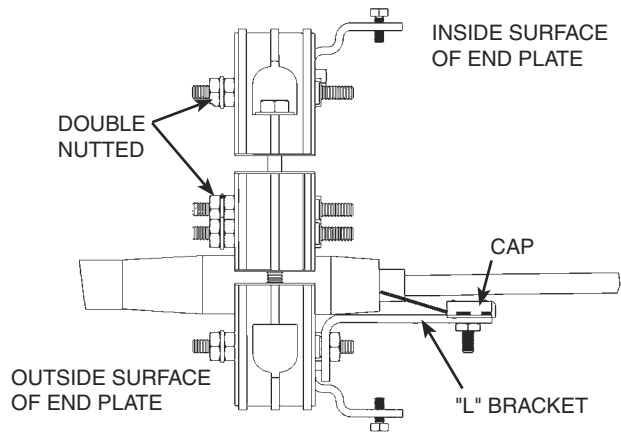

**FIGURE 20 - INSTALLING STRENGTH MEMBER**

**7.09** When all cables and/or plugs have been installed, tighten End Plate bolts by rotating 2 or 3 turns on each bolt so the End Plates come together evenly. Tighten bolts with torque wrench to 150 inch pounds. (Figure 21)

**NOTE:** Never use power tools for this operation.

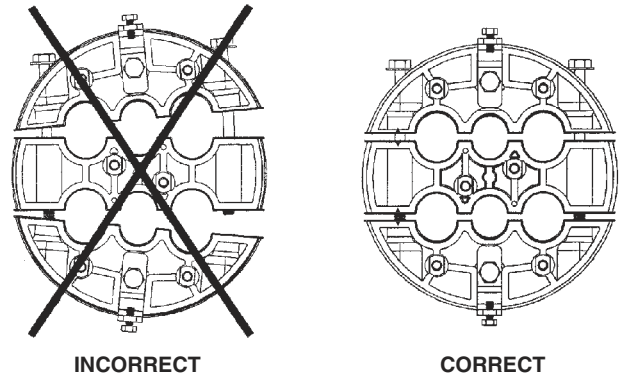

**FIGURE 21 - CORRECT END PLATE ALIGNMENT**

**7.10** Apply vinyl tape to the remaining 1/4"-1/2" (6.4-12.7 mm) (Paragraph 7.03) of exposed LOCK-TAPE Sealant on the cable outside the End Plate.



## 8.00 UNITUBE PREPARATION

**8.01** For unitube cable refer to Table 3 to determine the correct length of core tube necessary to enter the transition compartment when using the lower cable ports in the End Plate. Cables entering the upper ports will be transitioned into the compartment using a transition tube. Refer to Paragraph 10.02 for core tube lengths. See Section 14.00 for routing loose buffer tube cable into the storage compartment. When routing both unitube and buffer tube in the same closure, follow instructions for unitube application.

Unitube Length (mm) from Sheath to Transition Compartment		
COYOTE PUP Closure	Splice Configuration	
	Butt	
6.0" x 17" (152.4 x 431.8)	Top	3/4" (19.1)
	Bottom	6" (152.4)

TABLE 3

## 9.00 INSTALLING TRANSITION COMPARTMENT FOR UNITUBE CABLE

**9.01** See Figure 22 for the features of the transition compartment.

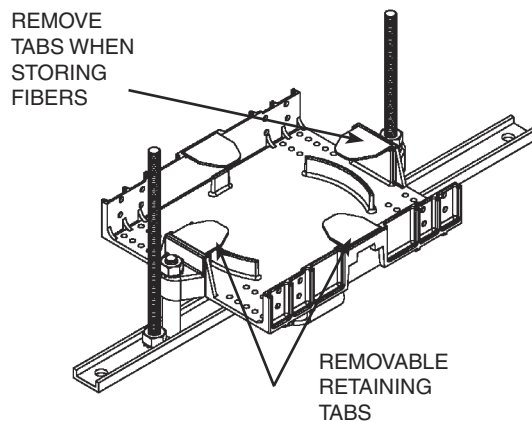

FIGURE 22 - TRANSITION COMPARTMENT

**9.02** The transition compartment assembly attaches to the torque bar bracket on the bottom of the end plates with the bolts provided. (Figure 23) Make sure the side of the torque bar labelled "3 Section End" is nearest the Three-section End Plate.

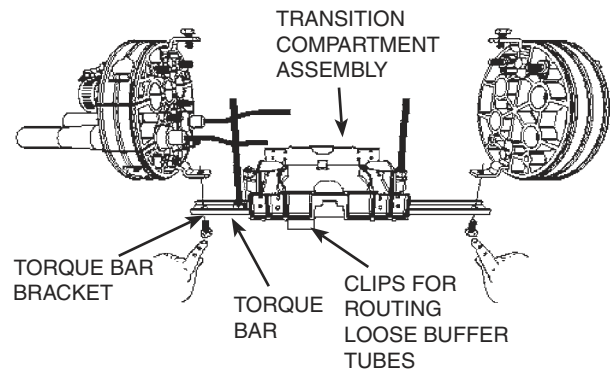

FIGURE 23 - INSTALL TRANSITION COMPARTMENT

**9.03** Remove splice tray hold down strap and transition compartment cover. (Figure 24A)

**PLP TIP:** If the hold down strap is snug against the studs, lift the tab using a screwdriver as demonstrated in Figure 24B.

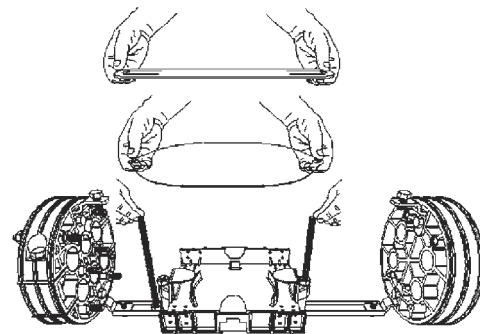

FIGURE 24A - REMOVE SPLICE TRAY HOLD DOWN STRAP AND COVER

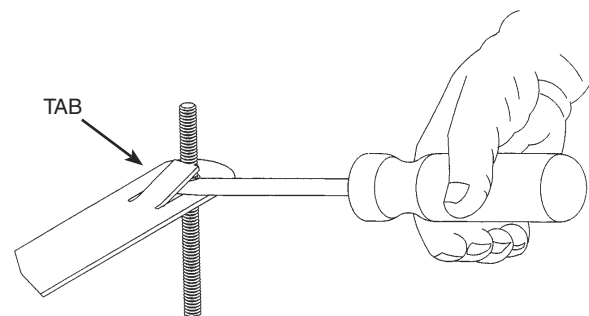

FIGURE 24B - HOLD DOWN STRAP REMOVAL

## 10.00 SECURING UNITUBE IN THE TRANSITION COMPARTMENT

**NOTE:** Prior to installing unitube cable, apply moisture blocking sealant (Catalog #80803448) into the end of the tube according to your company or cable manufacturer's practices.

**10.01** Secure unitube to the transition compartment as shown in Figure 25.

**NOTE:** It is important that all single cable tubes are secured in the correct position on the transition compartment.

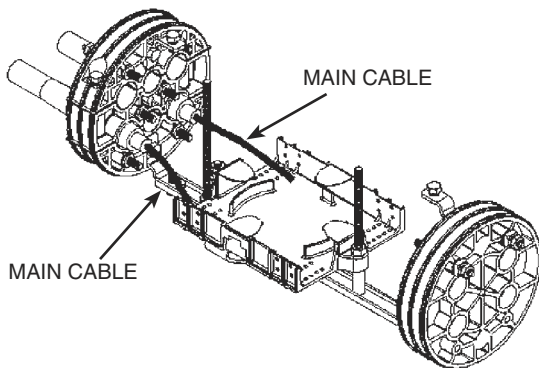

**FIGURE 25 - SECURING CABLE TUBE**

**10.02** Unitube cables entering through the top ports of the End Plate will require a transition kit (Catalog #8003280). The kit includes two lengths of tube approximately 24" (609 mm) long which can be field cut 7"-8" (178-203 mm). The smaller transition tube (.240" [6.1 mm] diam.) is for unitube cables ranging from 4-48 fiber count. The larger transition tube (.311" [7.9 mm] diam.) is for unitube cables ranging from 50-96 fiber count.

**10.03** Leave approximately 3/4" (19.0 mm) of cable tube for all cables entering the top ports of the End Plate. Determine which diameter transition tube is to be used. To measure the correct amount of transition tube necessary, hold it 1/2-3/4" (12.7-19.0 mm) past the unitube, make an "S" bend into the transition compartment 1/2" (12.7 mm) past the tie down ports in the bottom of the tray. Cut the transition tube at this mark and apply. (Figure 26)

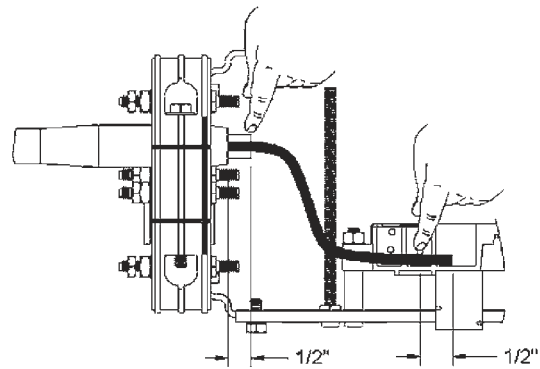

**FIGURE 26 - MEASURING TRANSITION TUBE**

**PLP TIP:** Install fibers in transition tube, then apply moisture blocking compound.

**10.04** Wrap the end of the transition tube with one layer of the felt tape provided and secure to the bottom of the transition compartment with two of the tie wraps provided. (Figure 27)

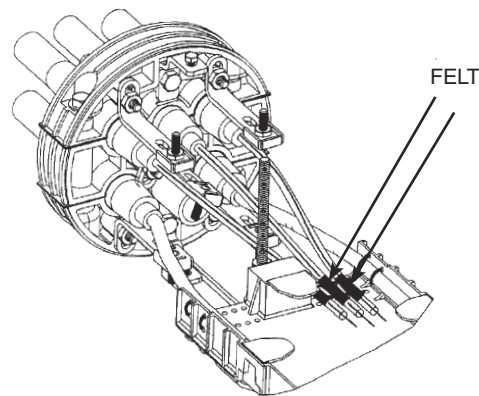

**FIGURE 27 - SECURING TRANSITION TUBE FOR CABLES ENTERING TOP END PLATE PORTS**

## 11.00 ROUTING AND STORING FIBER IN THE TRANSITION COMPARTMENT

**11.01** When routing fiber in the transition compartment for continuous loop applications, cut the fibers to be spliced at the midpoint of the loop. This allows for splicing in either direction. Lay the fibers to be spliced directly through the transition compartment exiting the opposite end. These fibers will be routed to splice trays 1-4. Wrap the continuous loop, and the fibers not being spliced, until all fibers are stored in the transition compartment. For cut cables bring all fibers to be spliced directly through the transition compartment exiting the opposite end of the same corner (Figure 28).

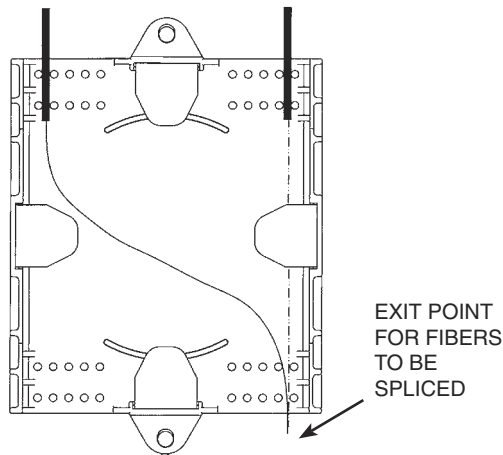

**FIGURE 28 - ROUTE FIBERS IN TRANSITION COMPARTMENT**

**12.00 INSTALLING FIBERS INTO TRANSPORT TUBES AND SECURING TO TRANSITION COMPARTMENT**

**12.01** Group fibers into bundles determined by how many fibers will be inserted into each transport tube. A maximum of six transport tubes can be terminated per splice tray.

**12.02** Push fibers through the transport tubes.

**NOTE:** For ribbon fiber application, fiber guide wires are provided. Suggested use is four ribbons per tube. (Figure 29)

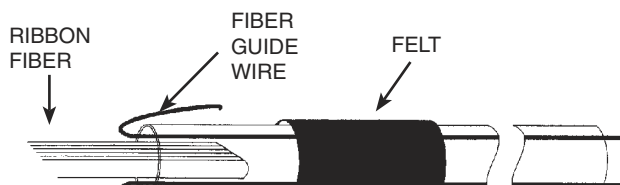

**FIGURE 29 - GUIDE WIRES IN USE**

**12.03** Select the required number of transport tubes and wrap one layer of felt tape 1/2" (12.7 mm) from one end of all transport tubes. (Figure 30)

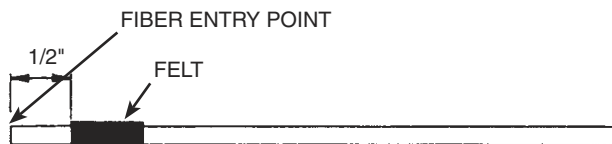

**FIGURE 30 - WRAP FELT TAPE**

**NOTE:** Fiber from transition compartment enters at felt tape end of transport tube.

**12.04** Repeat steps 12.01 through 12.03 for remaining transport tubes.

**PLP TIP:** To differentiate between the office and field side, place vinyl tape at the end of one set of transport tubes.

**12.05** Secure all transport tubes with the felt tape applied to the inside tie down holes in the transition compartment with two of the tie wraps provided. (Figure 31)

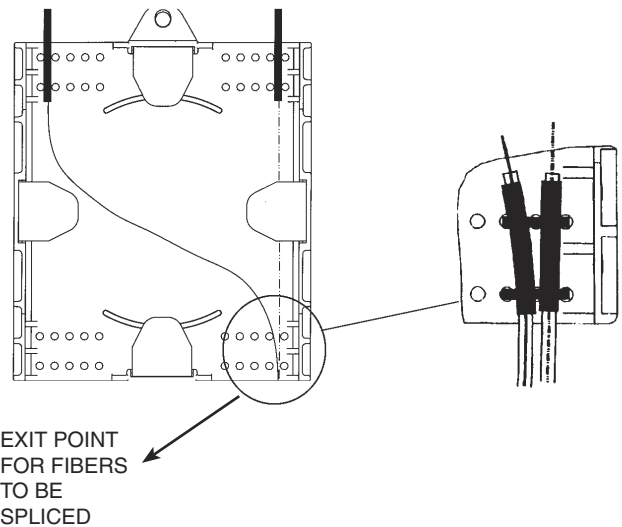

**FIGURE 31 - SECURE TRANSPORT TUBES**

**PLP TIP:** For ease of handling, group the transport tubes in multiples of six. This simplifies the arrangement of the final group of transport tubes in the transition compartment. (Figure 32)

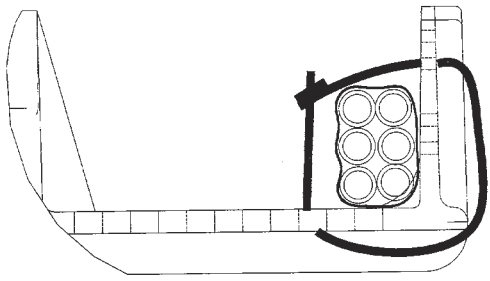

**FIGURE 32- GROUP TRANSPORT TUBES- SINGLE CLUSTER**

**12.06** Replace protective cover on transition compartment as in Figure 33.

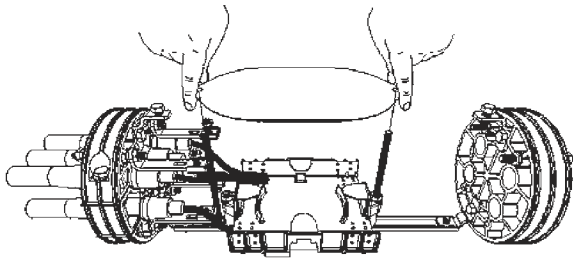

**FIGURE 33 - REPLACE COVER**

**13.00 SECURING TRANSPORT TUBES AND ROUTING FIBER IN SPLICE TRAYS**

**13.01** One splice tray is available for the COYOTE PUP Closure. The single fiber tray is designed for single fusion or single mechanical splice applications. The single fiber tray can accommodate 12 single fiber splices. (Figure 34) Refer to Table 1 for COYOTE Splice Tray capacity.

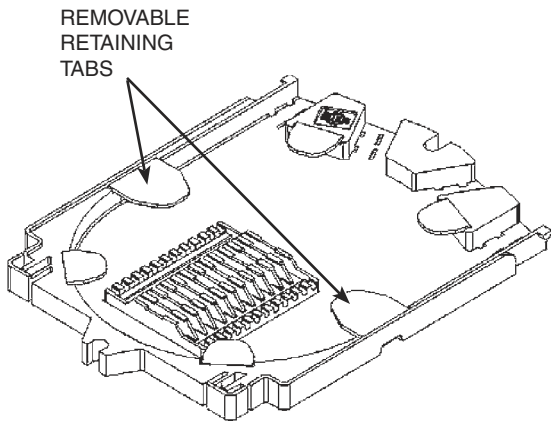

**FIGURE 34 - SPLICE TRAYS**

**13.02** Remove cover of splice tray. (Figure 35)

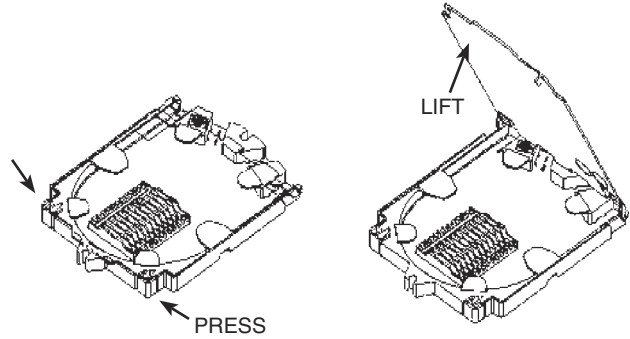

**FIGURE 35 - REMOVE SPLICE TRAY COVER**

**13.03** Position the transport tubes onto the splice tray so they extend 1/4" (6.4 mm) past the tie down holes and apply provided tie wraps as shown in Figures 36 A & B.

**PLP TIP:** For easy tie wrap installation, insert the tie wrap with the ridges on the inside of the loop, with the head opposite the notch in the splice tray. Insert the tail into the head. Press head down to the tray and hold in place while pulling the tail to tighten the tie wrap.

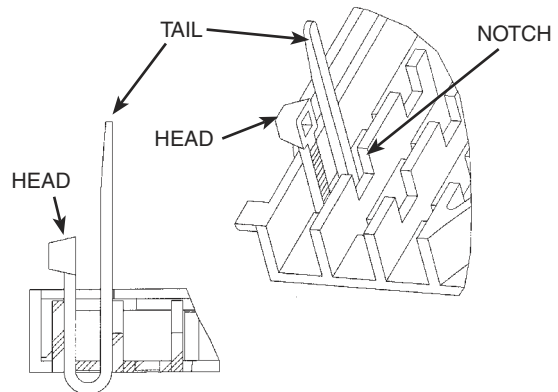

**FIGURE 36A - SECURE TIE WRAPS**

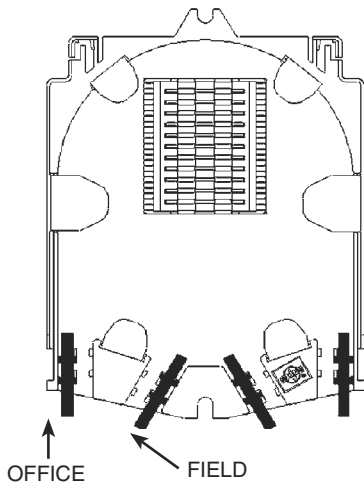

**FIGURE 36B - POSITION AND SECURE TRANSPORT TUBES**

**13.04** When routing the fiber in the single fiber tray for the COYOTE PUP Closure, route **fibers** 1-1/2 times around the splice tray and lay into the upper splice block (see Figure 37A).

**NOTE:** There should be a minimum of 42" (1070 mm) of exposed fiber for splicing.

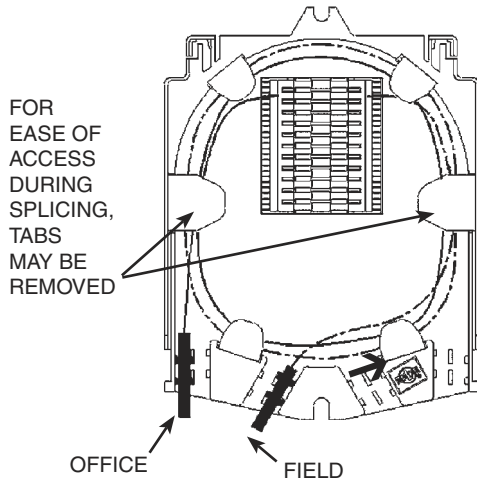

**FIGURE 37A - ROUTING FIBERS IN THE SINGLE FIBER SPLICE TRAY—FIBERS 1-6**

**13.05** Splice the fibers according to your accepted company practices. (Figure 38)

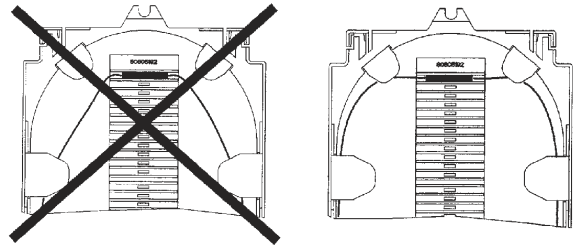

**FIGURE 38 - BEND RADIUS - IMPORTANT**

**13.06** Replace all tray retaining tabs.

**13.07** To replace tray cover, position pivotal arm on plastic cover underneath the hinges on the splice tray and snap into place. (Figure 39)

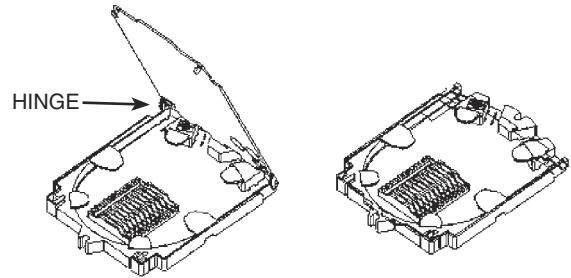

**FIGURE 39 - REPLACE SPLICE TRAY COVER**

**13.08** Slide all splice trays onto the threaded studs. See Figure 40 for proper splice tray alignment.

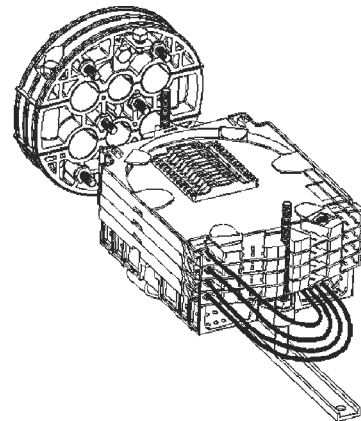

**FIGURE 40 - PROPER SPLICE TRAY ALIGNMENT**

**13.09** After all splices are completed, secure all splice trays onto the threaded studs by reapplying the splice tray hold down strap. (Figure 41)

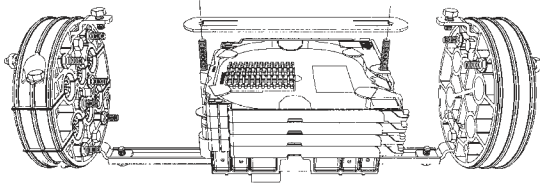

**FIGURE 41 - REPLACE SPLICE TRAY HOLD DOWN STRAP**

**13.10** Install the top torque bar to the upper torque bar brackets on the end plates with the bolts provided. (Figure 42) Make sure the side of the torque bar labelled "3 Section End" is nearest the Three-section End Plate.

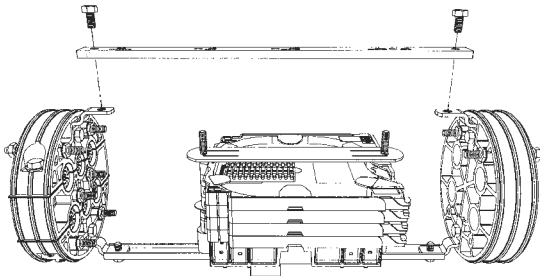
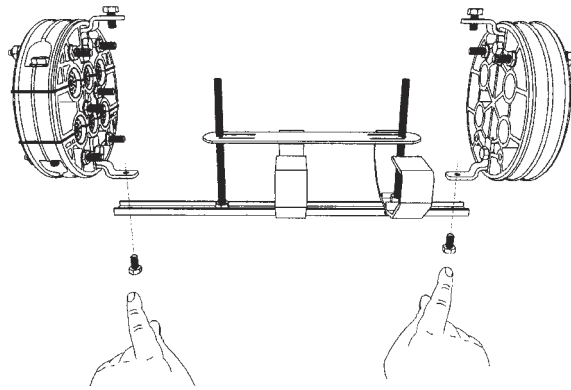

**FIGURE 42 - INSTALL TOP TORQUE BAR**

**13.11** See Section 15.00 for installing COYOTE Closure Shells.

## 14.00 ROUTING LOOSE BUFFER TUBE CABLE

**14.01** When routing both unitube and buffer tube in the same closure, follow instructions for unitube application beginning in Paragraph 8.00. For buffer tube alone, install the loose buffer tube storage compartment (Figure 43) to the torque bar bracket on the bottom of the End Plates with the bolts provided. Make sure the side of the torque bar labelled "3 Section End" is nearest the Three-section End Plate.



**FIGURE 43 - INSTALL LOOSE BUFFER TUBE STORAGE COMPARTMENT**

**14.02** Remove splice tray hold down strap. (Figure 44A)

**PLP TIP:** If the hold down strap is snug against the studs, lift the tab using a screwdriver as demonstrated in Figure 44B.

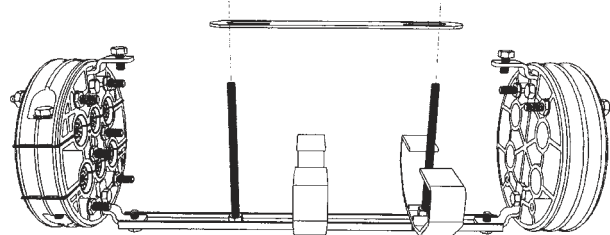

**FIGURE 44A - REMOVE SPLICE TRAY HOLD DOWN STRAP**

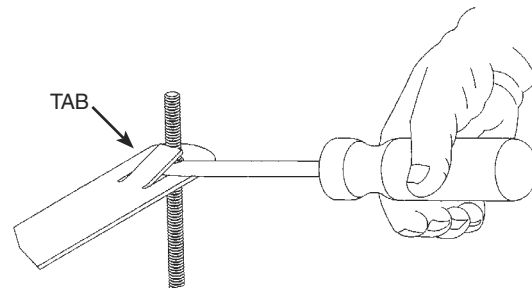

**FIGURE 44B - HOLD DOWN STRAP REMOVAL**

**NOTE:** See Table 1 for COYOTE Splice Tray capacities.

**14.03** When routing loose buffer tubes in the COYOTE PUP Closure, route the loose buffer tubes to be spliced through the storage compartment, exiting them both at the opposite end on the same side. Store any unspliced loose buffer tubes or continuous loop loose buffer tubes by routing them inside the storage brackets. (Figure 45)

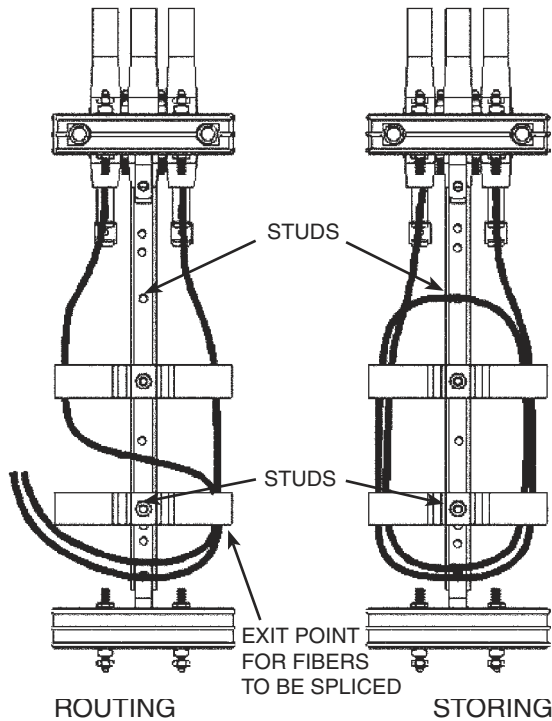

**FIGURE 45 - LOOSE BUFFER TUBE ROUTING AND STORAGE**

**14.04** Position the trays on the threaded studs. There should be a **minimum of 42" (1070 mm) of exposed fiber** for splicing in the tray. Lay the loose buffer tubes in the tray and make a mark on the tube 1/4" (6.4 mm) past the tie down holes. See Figure 46. Remove the loose buffer tube from this point outward. Clean exposed fibers according to accepted company practices.

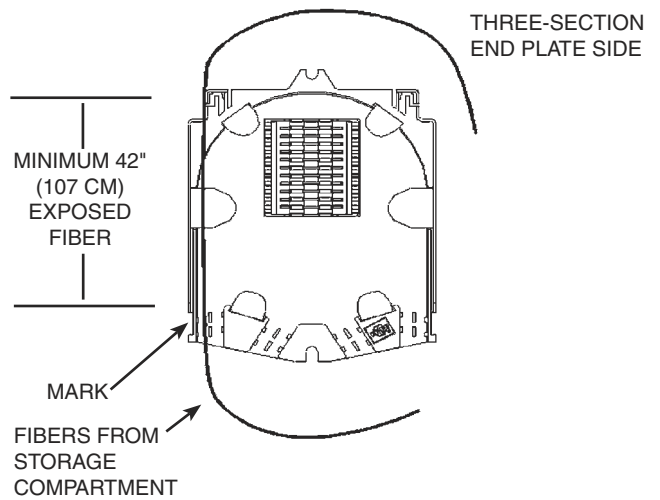

**FIGURE 46 - LAY TUBES IN TRAY AND MARK**

**14.10** Place one wrap of felt tape at the end of each loose buffer tube. Position the buffer tubes onto the splice tray so they extend 1/4" (6.4 mm) past the tie down holes and apply provided tie wraps as shown in Figures 47 A & B.

**PLP TIP:** For easy tie wrap installation, insert the tie wrap with the ridges on the inside of the loop, with the head opposite the notch in the splice tray. Insert the tail into the head. Press head down to the tray and hold in place while pulling the tail to tighten the tie wrap.

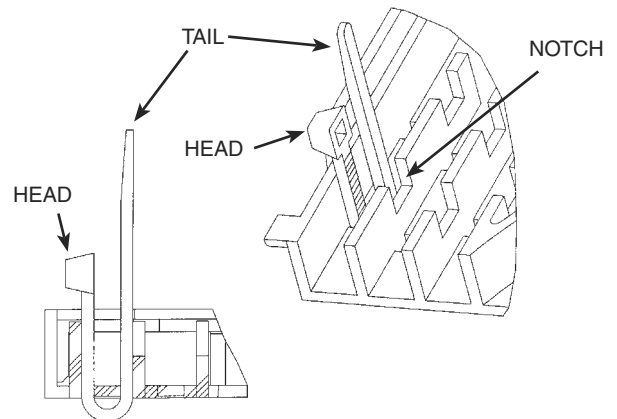

**FIGURE 47A - SECURE TIE WRAPS**

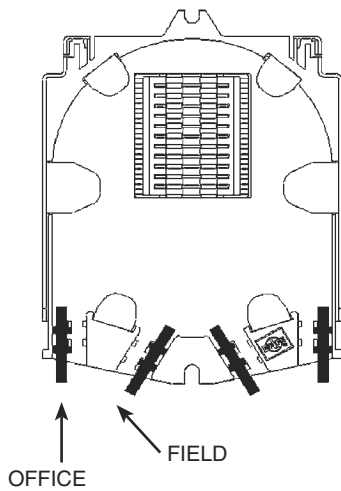

**FIGURE 47B - POSITION AND SECURE BUFFER TUBES**

**14.11** For routing the fiber in the **SINGLE FIBER SPLICE TRAY**, see Paragraph 13.04.

**14.13** To replace splice tray cover, splice tray hold down strap and torque bar see Paragraphs 13.07-13.10.

### 15.00 INSTALLING THE COYOTE CLOSURE SHELLS

**15.01** The neoprene in the shells must be pliable when installed. In cold weather (below 32° F), for new installation, or re-entry, warm shells prior to installation.

**15.02** Remove protective paper liners from shells. Take care to keep gasket area clean.

**15.03** The top and bottom shells are mated together around the End Plates. The top shell is identified by an air valve and bolts. Position the top and bottom shells around the End Plates in the grooves located in each shell half.

**15.04** Align the closing hardware and first **HAND-TIGHTEN** in the torque sequence shown in Figure 48. Once all closing hardware is hand-tightened, repeat the torque sequence using a torque wrench set at 55 inch pounds. After completing torque sequence, re-torque the two outside corner bolts on all four corners (in bold).

**NOTE:** SET TORQUE TO 55 INCH POUNDS.

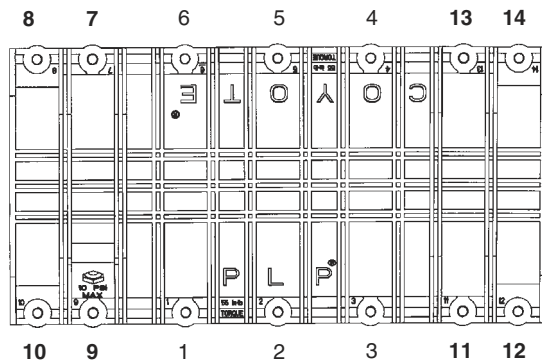

**FIGURE 48 - TORQUE SEQUENCE**

**15.05** Flash test and soap COYOTE PUP Closure according to accepted company practices, to a maximum of 10 psi.

**15.06** Release pressure from closure and replace cap on air valve.

### 16.00 EXTERNAL BOND PROCEDURE

**16.01** For all ground inserts with cables attached, loosely attach a bond clamp (2 per kit) (Catalog #8003281) outside the End Plate. The clamp attaches between the two nuts on the stud on the outside of the End Plate. **NOTE: DO NOT REMOVE THE NUT ON THE GROUND INSERT CLOSEST TO THE END PLATE.** When reattaching hex nut, secure using a can wrench, or torque wrench set no higher than 40 inch/pounds. Route bond ribbon (not supplied) through the clamps and to the ground source. Tighten all clamps. (Figure 49)

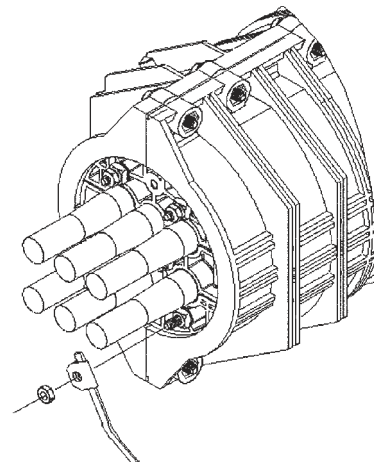

**FIGURE 49 - BOND CABLES**

**16.02** For bonding all isolated grounds together on the exterior of the COYOTE PUP Closure, use Exterior Bond Braid Kit (Catalog #8003360).



**16.03** The eyelets of the Exterior Bond Braid Kit are placed at intervals to align with isolated ground studs on the exterior of the COYOTE End Plate.

**16.04** Remove one hex nut from each of the ground studs.

**16.05** Apply the Exterior Bond Braid and re-apply hex nuts and tighten. When reattaching hex nuts, secure using a can wrench, or torque wrench set no higher than 40 inch/pounds.

**16.06** Attach tail of the Exterior Bond Braid via the remaining eyelet to the ground source as per company practice.

## 17.00 STRAND MOUNT PROCEDURE

**17.01** The Adjustable Aerial Hanger Bracket (Catalog #8003325) can be used for applications where the Closure is being secured to the strand.

**17.02** Remove one hex nut from each of the two upper ground inserts. (Figure 50)

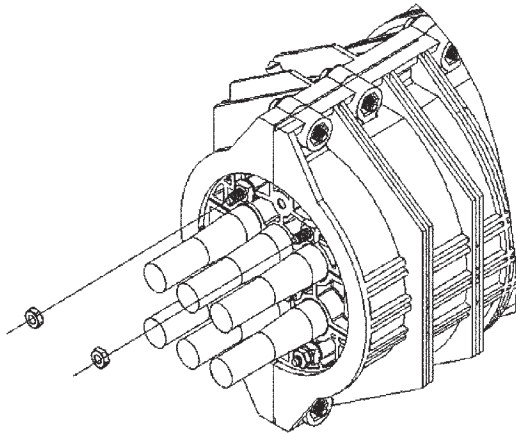

**FIGURE 50 - REMOVE HEX NUTS**

**17.03** Place hanger bracket onto ground inserts. (Figure 51)

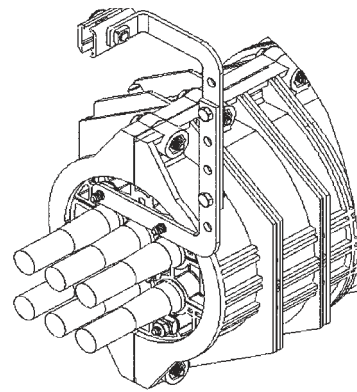

**FIGURE 51 - PLACE HANGER BRACKET**

**17.04** Secure hanger bracket to ground inserts with hex nuts and tighten. When reattaching hex nut, secure using a can wrench, or torque wrench set no higher than 40 inch/pounds. (Figure 52)

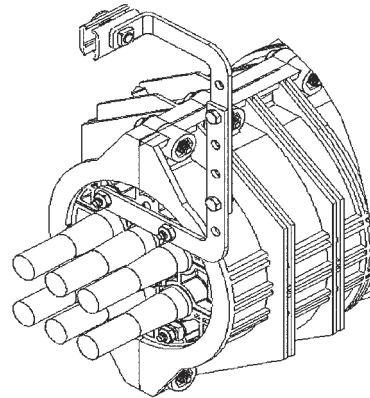

**FIGURE 52 - SECURE HANGER BRACKET**

**17.05** Repeat Steps 17.02 through 17.04 to install hanger brackets onto other end plate.

**17.06** After attaching hanger brackets to end plates, secure Closure to strand with Aerial Suspension Clamps. (Figure 53)

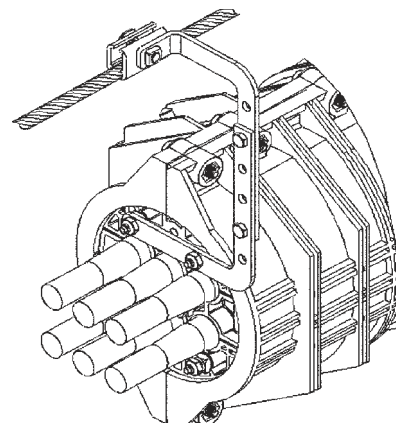

**FIGURE 53 - SECURE CLOSURE TO STRAND**

## 18.00 MANHOLE SUPPORT BRACKET KIT INSTALLATION

- 18.01** The Manhole Support Bracket Kit (Catalog #8003279) can be used for applications to secure the COYOTE PUP Closure to manhole racking or hand hole racking.
- 18.02** Remove one hex nut from each of the two upper ground inserts.
- 18.03** Place Manhole Support Bracket onto ground studs.
- 18.04** Secure bracket to ground studs with hex nuts and tighten. When reattaching hex nuts, secure using a can wrench or torque wrench set no higher than 40 inch/pounds.
- 18.05** Repeat steps 18.02-18.04 to install Manhole Support Bracket to the other End Plate.
- 18.06** After attaching brackets to both End Plates, slide the long support bar over the "Ts" on top of the Manhole Support Brackets until the support bar is centered over the COYOTE PUP Closure.

**PLP TIP:** Cable tie the support bar to the rack steps for added security.

## 19.00 BURIED INSTALLATION

**NOTE:** COYOTE PUP Closures may be direct buried if the following precaution is taken.

- 19.01** The COYOTE PUP Closure must be completely surrounded by 1-2' (310-610 mm) of sand or fine gravel prior to back filling.
- 19.02** Ground according to accepted company practices.

## 20.00 MAINTENANCE PROCEDURES

- 20.01** The COYOTE PUP Closure is designed for numerous re-entries.
- 20.02** Be sure to clean shells and End Plates thoroughly to remove sand, dirt and other foreign substances.
- 20.03** Any bent studs or stripped nuts should be replaced. Only use hardware supplied by Prefomed Line Products.

**20.04** The neoprene gasket in the shells should be lubricated prior to reapplication if they are dry. A uniform thin layer is all that is necessary. Only use lubrication supplied by Prefomed Line Products (Catalog No. 80801566).

**20.05** Any shells that are damaged must be replaced.

**20.06** Prior to reinstallation, the neoprene gasket on the shells should be allowed to return to its original state. Warming the shells speeds up the process.

**20.07** If additional cables are added in the future, do not reuse the Three-Section End Plate.

## 21.00 SAFETY CONSIDERATIONS

**21.01** This application procedure is not intended to supersede any company construction or safety standards. This procedure is offered only to illustrate safe application for the individual. Failure to follow these procedures may result in personal injury.

**21.02** When working in the area of energized lines, extra care should be taken to prevent accidental electrical contact.

**21.03** For proper performance and personal safety, be sure to select the proper size PREFORMED™ Product before application.

**21.04** This product is intended for use by trained technicians only. This product **should not be used** by anyone who is not familiar with, and not trained to use it.



# **PREFORMED** LINE PRODUCTS

P.O. Box 91129, Cleveland, Ohio 44101 • 440.461.5200 • [www.preformed.com](http://www.preformed.com) • e-mail: [inquiries@preformed.com](mailto:inquiries@preformed.com)

**SP2871-4**