

EXP

These bolted cross-pad clamps are intended for making connections between stranded conductors/stems and pads. These clamps should not be used as adaptors.

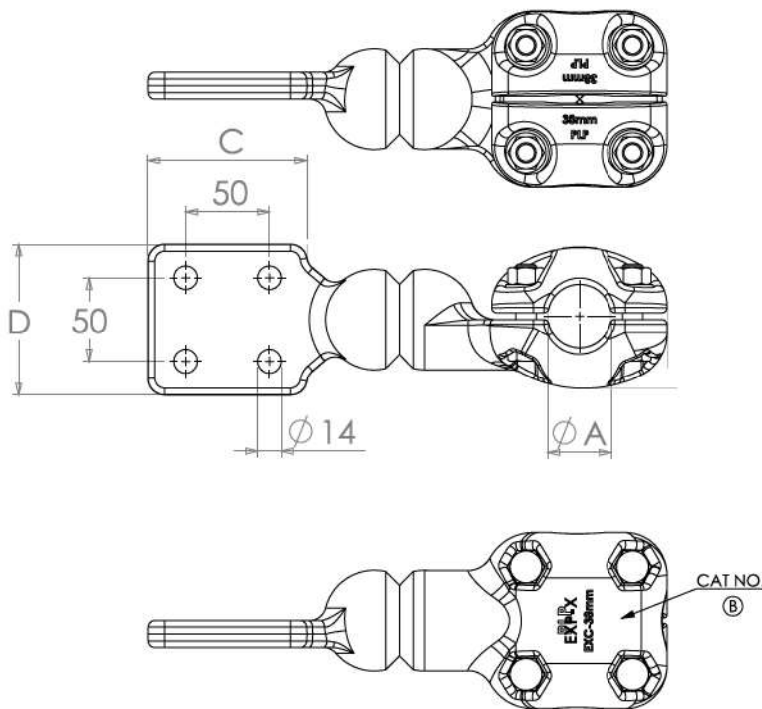

NOTES:

- To connect a flat terminal to a stranded conductor by bolting palm to terminal and bolting conductor.
- Recommended fasteners M12 GR. 8.8 HDG torque to 45Nm.
- All terminal, palm and conductor surfaces to be cleaned with stainless steel wire brush and a suitable conductive grease applied before use.
- Material: Cast aluminium.
- Supplied in clear, sealed, heavy duty, UV stabilized plastic bag.
- Cat. no. to be stamped as show .

NEW TYPE DESIGNATION	OLD TYPE DESIGNATION	STEM DIAMETER (A) (mm)	PALM SIZE (C X D) (mm)	MAX RATING (A)	MAXIMUM VOLTAGE [UM] (KV RMS)
EXP - A	STP 26	26	100 X 100	833	245
EXP - B	STP 38	38	100 X 100	1300	300

- All clamps supplied with M12 HDG, nuts and washers
- Recommended Torque: 45 Nm