

POWER MAX™
Tilted (5° & 10°) Array
ASSEMBLY INSTRUCTIONS

**step-by-step
assembly and installation**

POWER MAX™ Tilted (5°, 10 °) Array Ratings

The POWER MAX™ conforms to ANSI/UL UL2703 (2015) Standard for Safety First Edition: Mounting Systems, Mounting Devices, Clamping/Retention Devices, and Ground Lugs for Use with Flat-Plate Photovoltaic Modules and Panels.

Electrical

Note: Electrical installations must be in accordance with the National Electric Code ANSI / NFPA 70. Contact your local Authorities Having Jurisdiction (AHJ) for additional details.

Max Overcurrent Protective Device (OCPD) Rating: 25A

Equipment Grounding Conductor Sizing

Module Fuse Rating	Copper Wire Size
<15 AMPS	#14 AWG 90°C
<20 AMPS	#12 AWG 90°C
20-60 AMPS	#10 AWG 90°C

Module Clamps

Module clamps have integrated grounding and have been tested to UL2703.

See Module Compatibility List for list of approved modules.

Module Orientation: Landscape

Fire Class Resistance Rating

The system fire class rating is only valid when the installation is conducted strictly in accordance with this manual.

The assembly is to be mounted over a fire resistant roof covering rated for the application.

Meets the requirements of Class A Low Slope Symmetrical & Asymmetrical Applications when using Type 1, Listed Photovoltaic Modules.

Structural Certification

Mechanical Load Rating: Exceeds the minimum design load rating of UL2703 section 21.4 (10 psf downward, 5 psf upward, 5 psf downslope) load. See Module Compatibility List for rated loads. Structural capacity also available upon PE review.

Marking

Product markings identified per UL2703 are to be located in a location that is readily accessible for inspection.

Preformed Line Products

Model: Power Max

Manufacture Date: xx/xx

Load Rating: See Installation Instructions

Fire Class Rating: See Installation Instructions for Installation Requirements to achieve a Specified Fire Class Rating.



Intertek
UL2703

p/n 5800113

POWER MAX™ Tilted (5°, 10°) Array

WARNING

Be certain that the tilt angle and corresponding ballast are carefully followed in accordance to the project specific design specifications. Failure to do so could lead to catastrophic structural failure and severe personal injury or death.

About the product

The POWER MAX™ is a non-penetrating structure, i.e., the structure does not get screwed, bolted or otherwise fastened to the roof substrate. Instead, it is weighted in place to the roof substrate using concrete-cap blocks as ballast.

Important Installation Considerations

- Minimum Setback of 3 feet
- Roof slope cannot exceed 5°
- Consulting with a local building department and/or professional engineer is recommended.

Grounding Considerations

The POWER MAX™ requires no additional grounding devices and has been evaluated to meet UL2703 standard for PV mounting systems.

For questions on a specific installation, please: Contact us by Phone: 800-260-3792

Send an Email request: info@plpsolar.com

About these instructions:

- They are intended to be used by individuals with sufficient technical skills for the task. Knowledge and use of hand tools, measuring devices and torque values is also required.
- They include various precautions in the forms of Notes, Cautions, and Warnings

to assist in the assembly process and/or to draw attention to the fact that failure to follow certain assembly steps may be dangerous and could cause serious personal injury and/or damage to components. Following the step-by-step procedures and these precautions should minimize the risk of personal injury or damage to components while making the installation safe and efficient.

Periodic Inspection

Periodic re-inspection is a recommended system maintenance procedure to check for any loose components and any corrosion. If any loose components or any corrosion is found, the affected components are required to be replaced immediately, with the original mounting system manufacturer's component parts.

Required Tools

- 1/2 inch wrench or socket for 5/16 inch module clamp hardware
- Torque wrench
- Ratchet wrench
- Ratchet extension bar
- Tape Measure
- Square
- Chalk Line

WARNING

1. Preformed Line Products (PLP) is not liable for, and makes no warranty on, expressed or implied, the suitability of roofing, *in situ* weatherproofing materials, effect of adjacent buildings and/or equipment geometry, and other installation issues which are outside of PLP's scope. PLP's sole liability is set forth in its terms and conditions of sale. Please contact the roofer or warranty holder of the roof or building envelope system prior to the installation of a solar structural array, to confirm acceptance and compatibility of the penetration, attachment, and roof contact methods provided and/or proposed in this manual.
2. PLP offers no liability/warranty on any racks not installed to approved layout by PLP. Furthermore, PLP has no obligation to evaluate adjacent building or equipment geometry that may affect the wind dynamics and pressures exerted on the solar array and disclaims any liability related thereto.
3. The POWER MAX™ system is to be installed over adhered or fixed roof surfaces only. If additional roof protection materials are added under the POWER MAX™ structure, including slip sheets, drain mats or sacrificial layers, those materials must either be adhered to the main roofing material or trimmed to fit only under the POWER MAX™ trays.
4. Stainless Steel hardware can gall when tightened too quickly. Installer should use a Silver Grade anti-seize compound prior to assembling any stainless steel hardware. Do not use an impact driver. All other driver types should be set to low speed settings.
5. Periodic re-inspection is a recommended system maintenance procedure to check for any loose components and any corrosion. If any loose components or any corrosion is found, the affected components are required to be replaced immediately, with the original mounting system manufacturer's component parts.

Table of Contents

Before You Start

Tilted (5° and 10°) Array Components.....	1
Understanding Ballast Requirements.....	2

Assembly Steps

1. Snap Chalk Lines on Roof	3
2. Install the Brackets	3
3. Install the Ballast Support Tubes.....	4
4. Positioning the Trays on Roof Top.....	4
5. Install Ballast	5
6. Install Modules	5

Appendices

A-1: Grounding/Bonding Path	8
A-2: Install WEEB-LUG-8.0	9
A-3: Installing High Wind Ballast (not required on all systems).....	10
A-4: Compatible Modules	11

Tilted (5° & 10°) Array Components

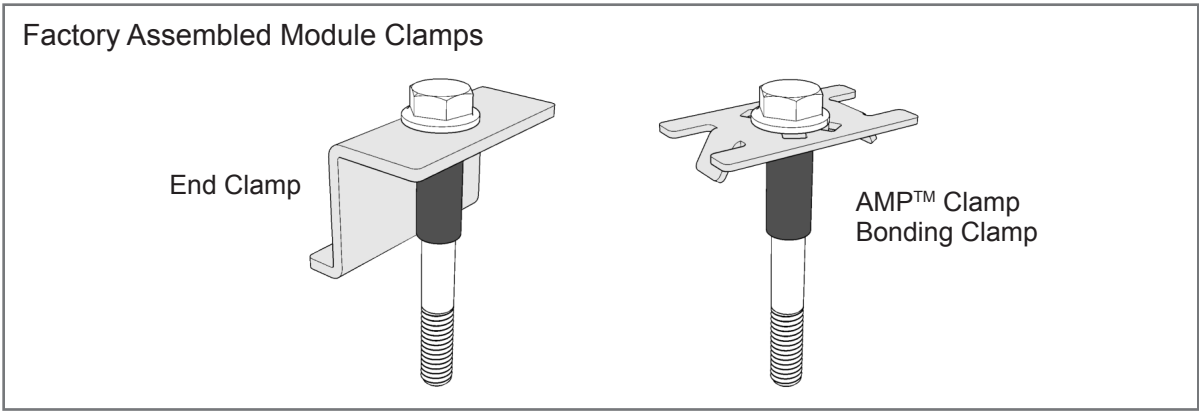
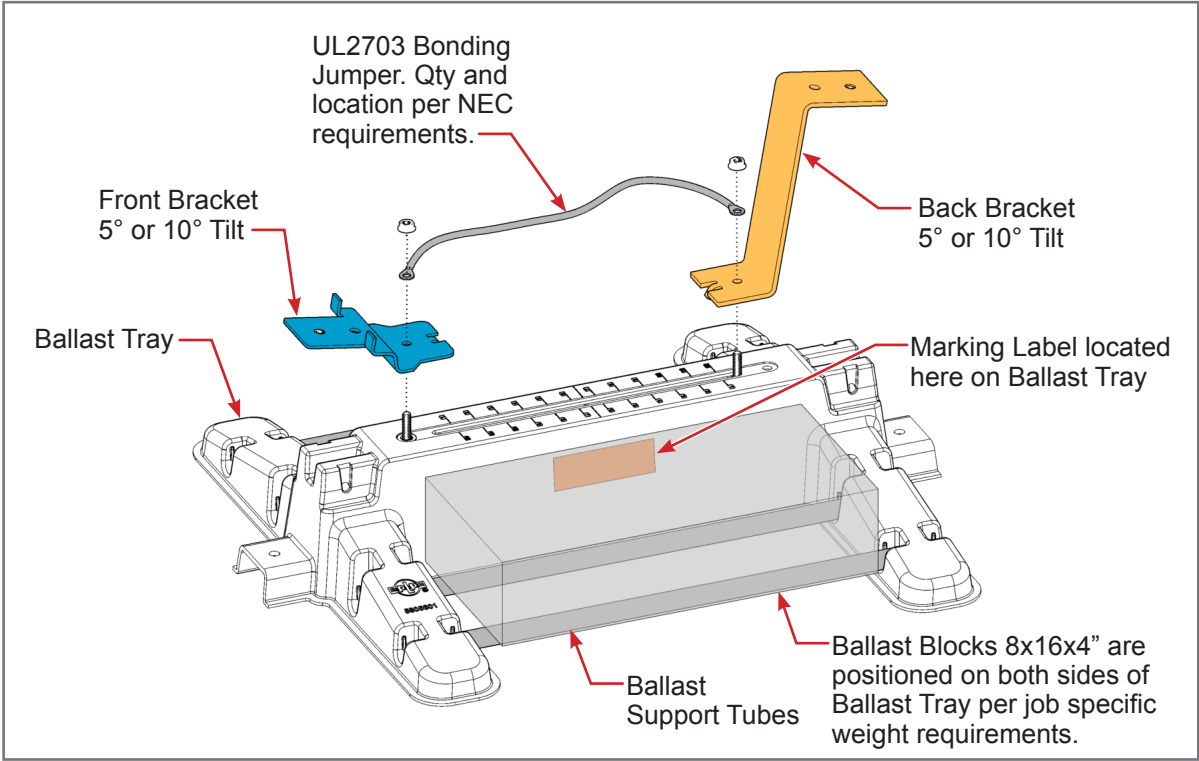

Understanding Ballast Requirements

CAUTION

Without exception, the ballast must be installed/applied per the job specific project drawings and weight requirements. Be absolutely certain that the concrete blocks meet the specified weights. Failure to do so could lead to a catastrophic structural failure and severe personal injury or death. Furthermore, failure to meet specifications voids the system warranty.

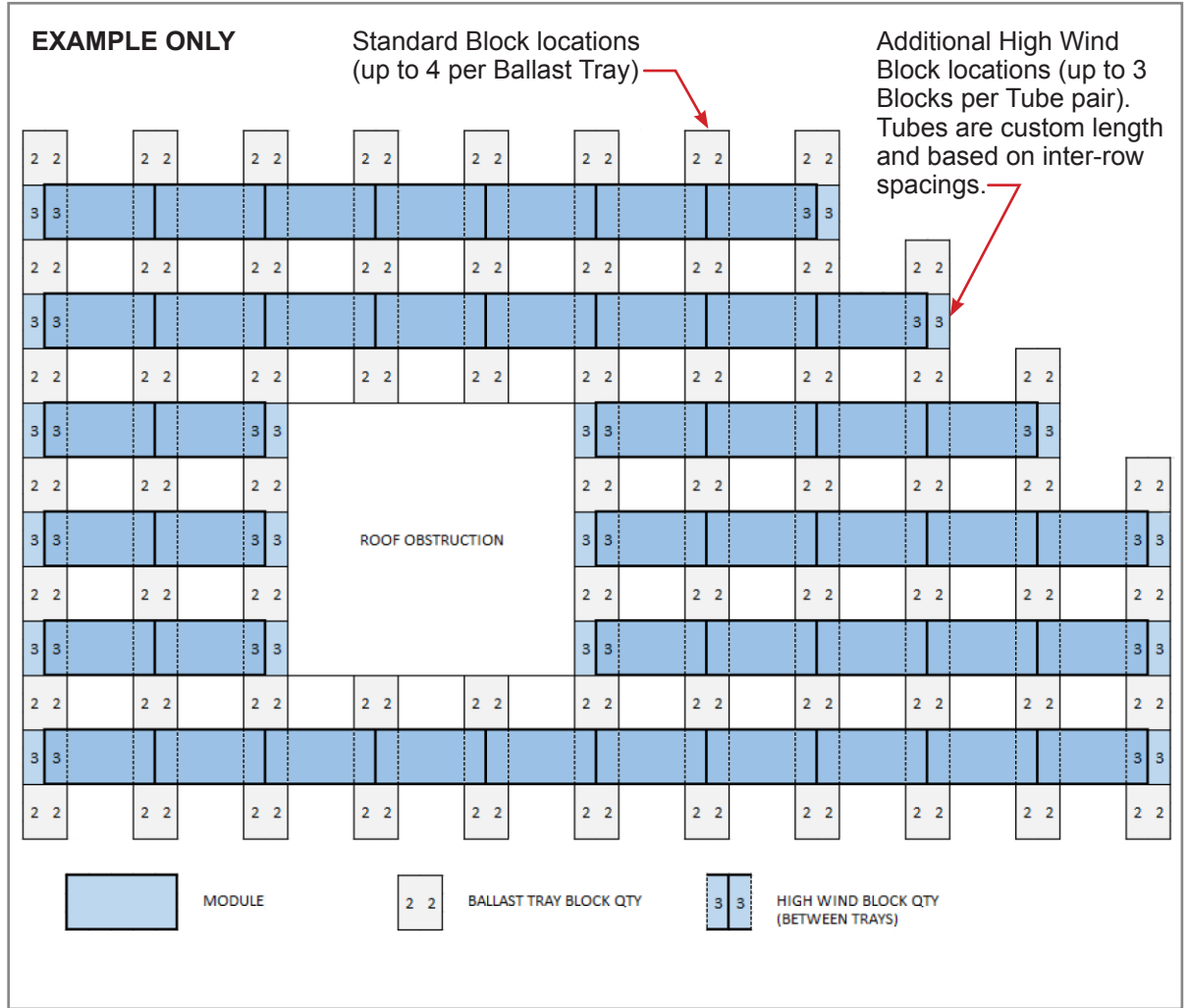

This sample layout shows the specific number of Ballast Block required per Tray by Tray location. These numbers will range from 1-4 blocks.

For further details on minimum/maximum block quantities and arranging of ballast blocks, refer to project specific drawing.

1 Snap Chalk Lines on Roof

Snap perpendicular chalk lines using the 3-4-5 triangulation method. In this example, a factor of 5 feet has been used. On larger systems, use a factor of 10 feet.

The chalk lines represent the E-W and N-S coordinates of the array.

CAUTION

Do not rely on the roof edges or parapets when snapping chalk lines, as they are not always square.

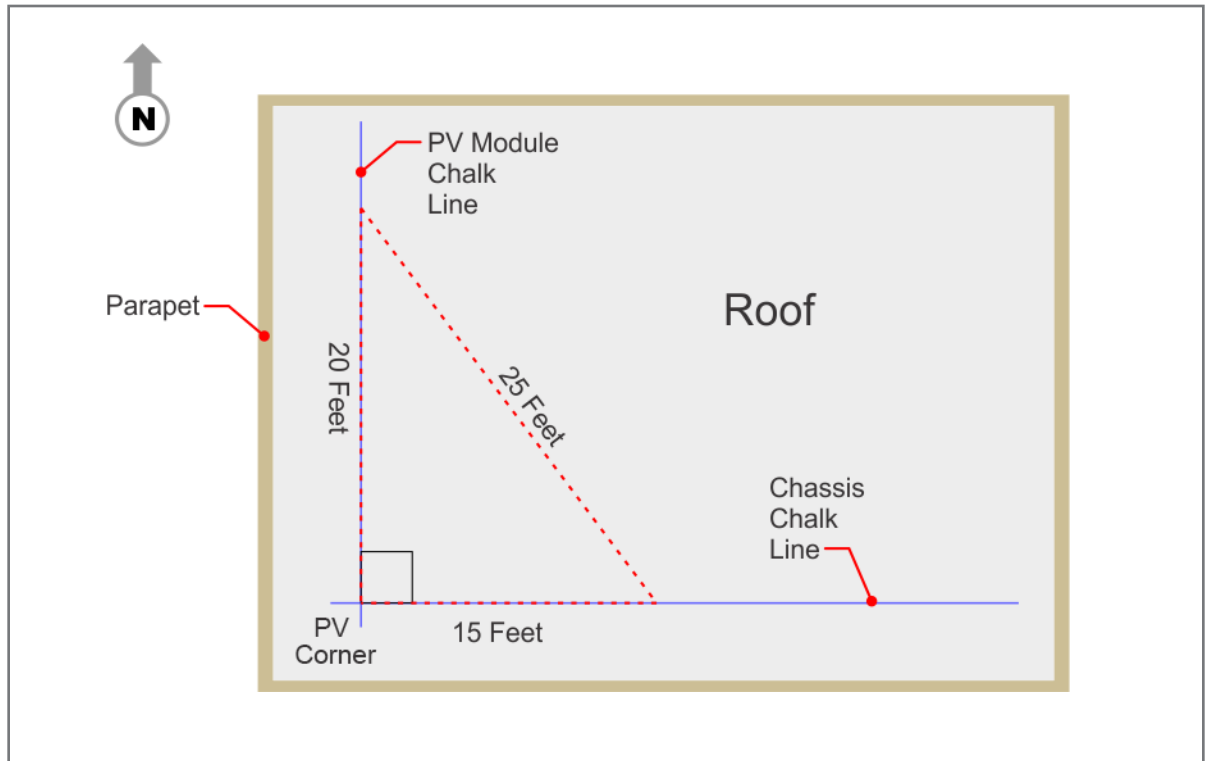

2 Install the Brackets

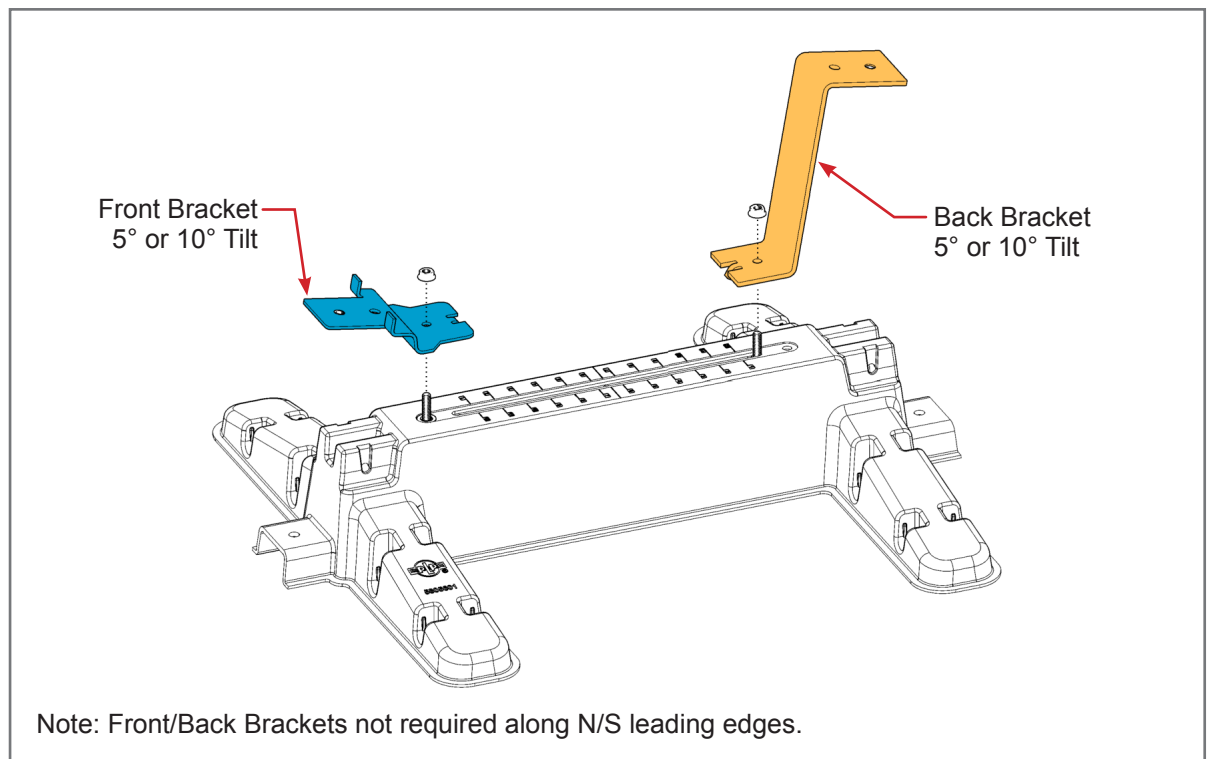

Install the Brackets as shown above. Secure with 5/16-18 Flange Nuts. **Torque to 15 ft.-lbs.**

3 Install the Ballast Support Tubes

CAUTION
 If the Ballast Support Tubes come in contact with the roof surface, that surface must be protected with a manufacturer approved slip sheet. Be aware of peaks on the roof which may come in contact with the Ballast Support Tubes.

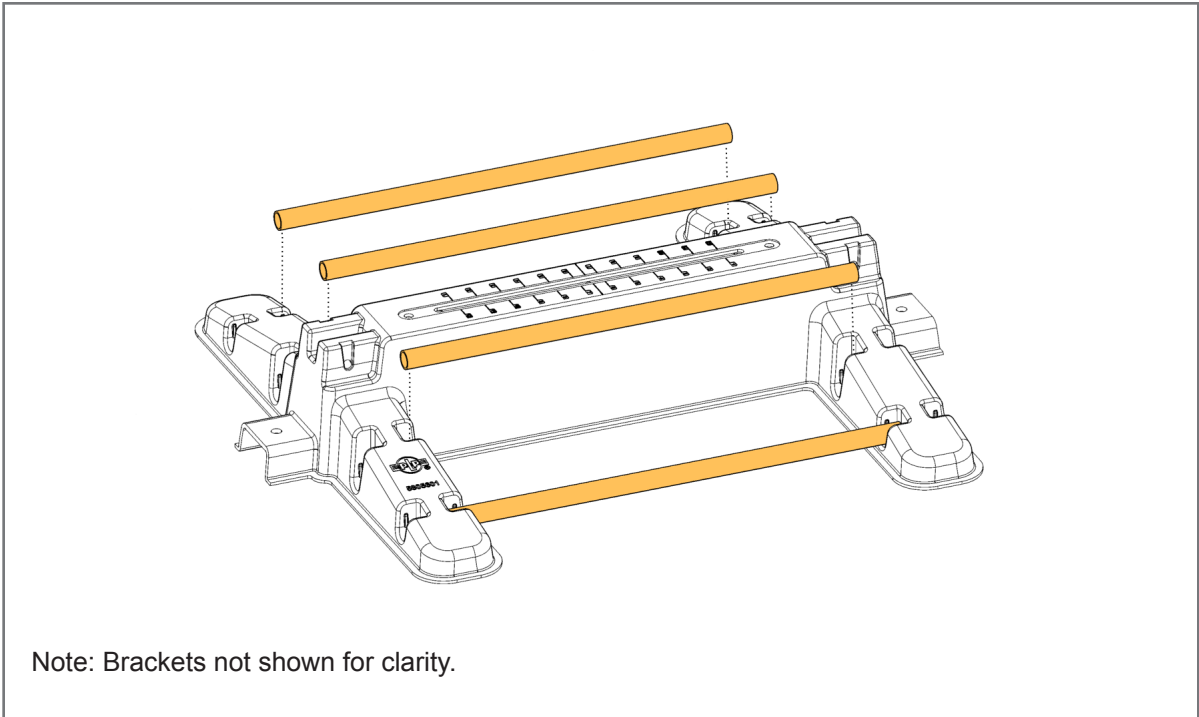

Note: Brackets not shown for clarity.

Install each of the four Ballast Support Tubes in their respective notches of the Tray.

4 Positioning the Trays on Roof Top (rough positioning)

NOTE
 Final spacing and alignment of the Trays will be set as PV Modules are installed.

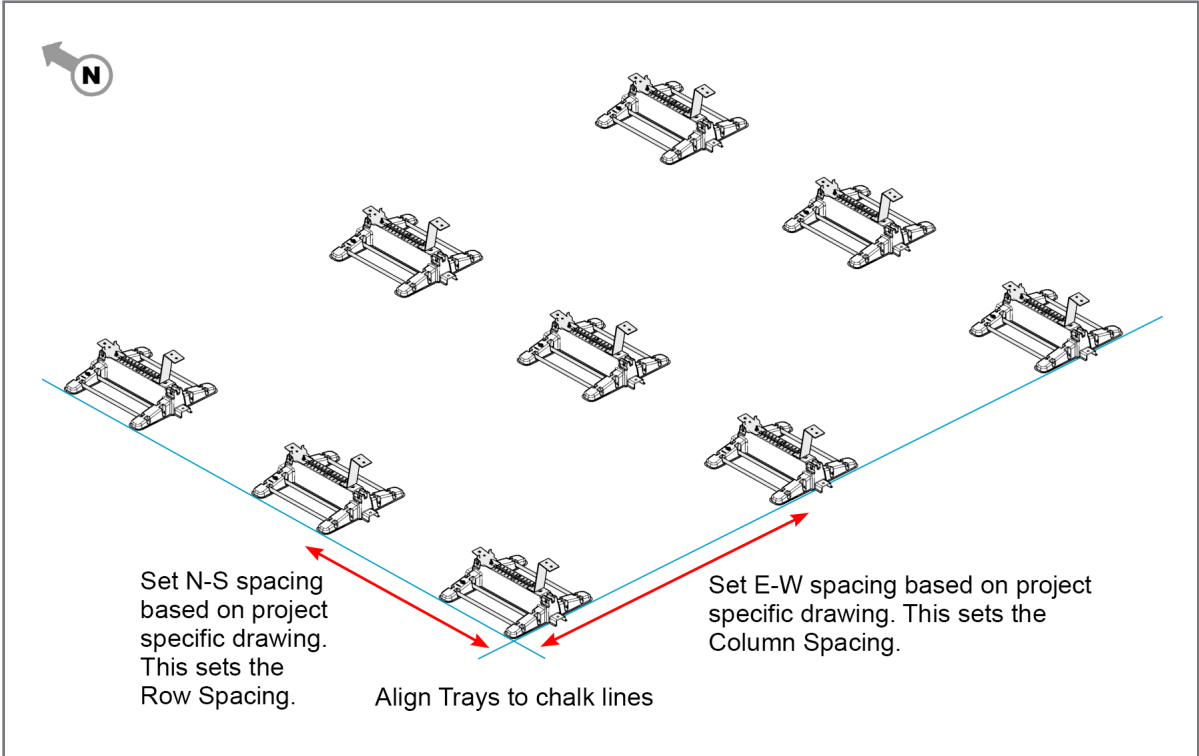

Position the southernmost and (in this example) the westernmost Trays along their respective chalk lines, roughly spacing the Trays as shown. Roughly place

the Trays within the interior of the array using the dimensions shown above.

5 Install Ballast

CAUTION

Without exception, the ballast must be installed/applied per the job specific project drawings. Be absolutely certain that the concrete blocks meet the specified weights. Failure to do so could lead to a catastrophic structural failure and severe personal injury or death. Furthermore, failure to meet specifications voids the system warranty.

PLP Tip!

Place all Ballast Blocks in location prior to Module installation.

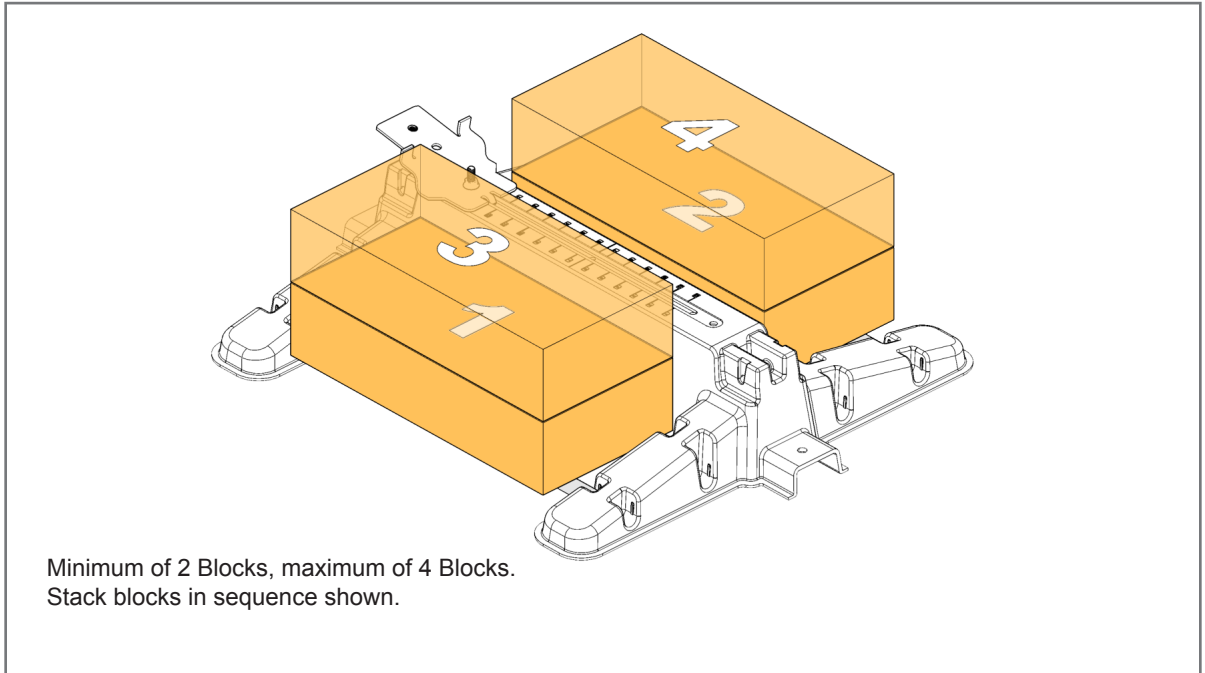

Install the required Ballast per the job specific ballast requirements.

6 Install Modules

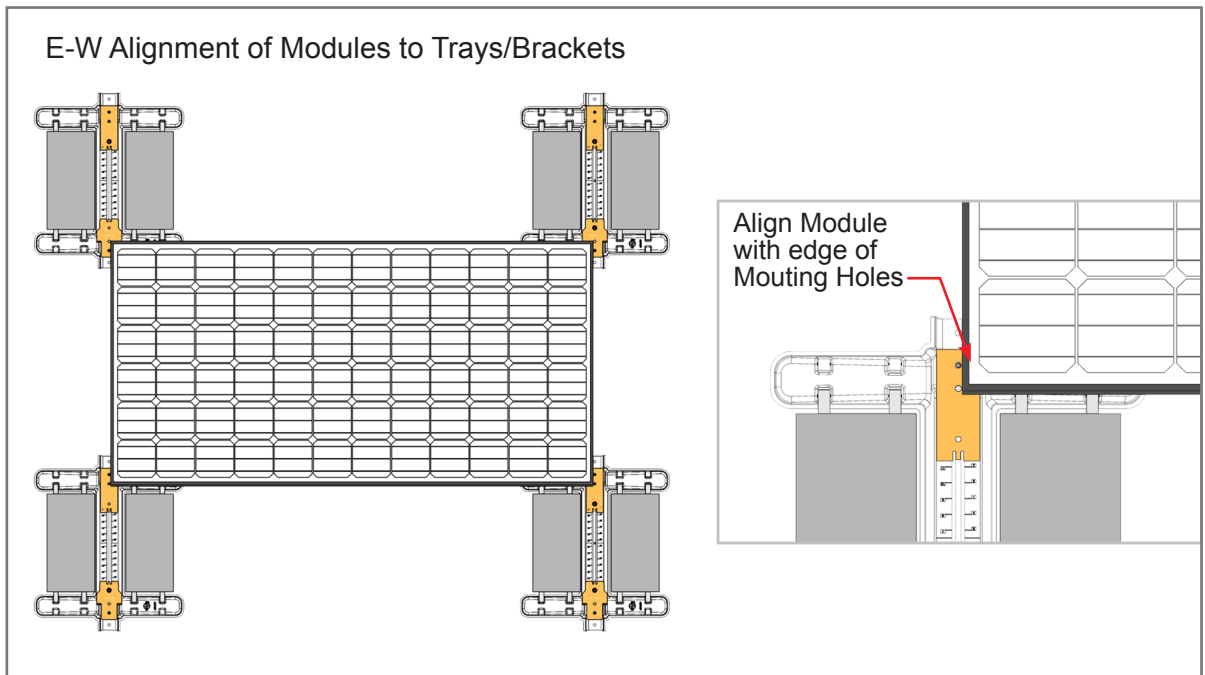

The Trays and Modules relative east/west positioning is established via the mounting holes of the Front and Back Brackets. Align the Module Frame as close as possible to the edge of the threaded mounting holes while leaving just enough clearance to thread the Bolt/Sleeve of the Module Clamps into the Brackets.

6 Install Modules (cont.)

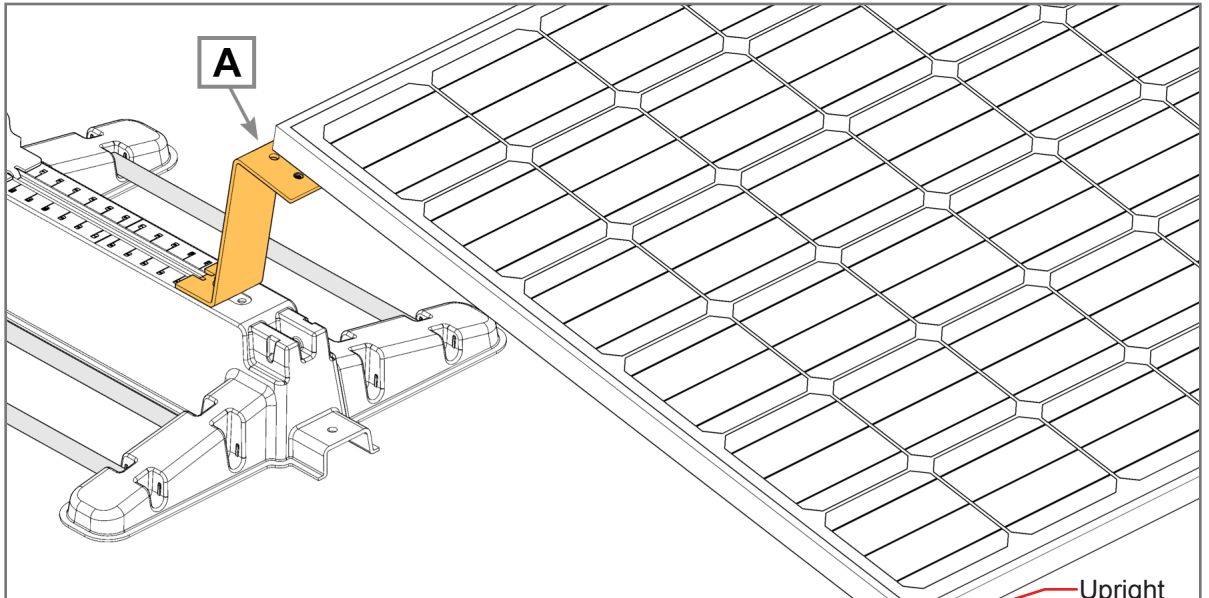

Rest Module on the Brackets as shown while allowing the southern edge of the Module to rest against the upright Tab of the Front Bracket.

The E-W alignment is such that the Module Frame aligns with the edge of the threaded holes where the End Clamp(s) are mounted.

Note: Ballast blocks not shown for clarity.

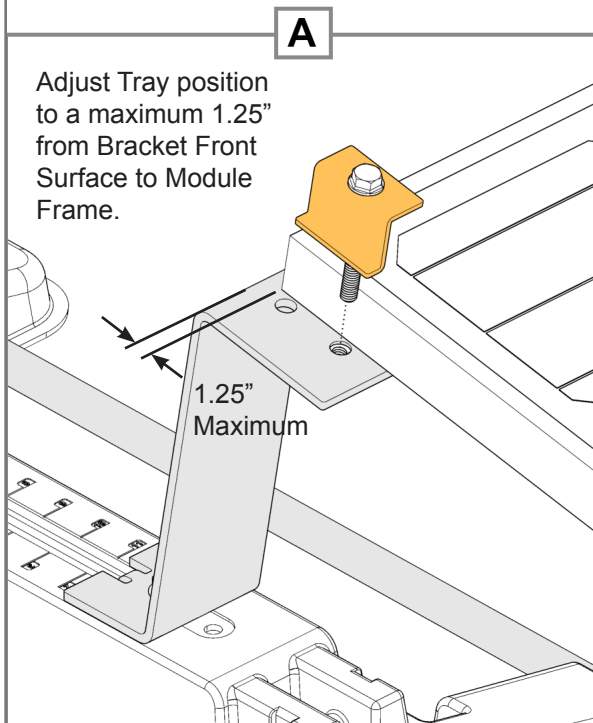
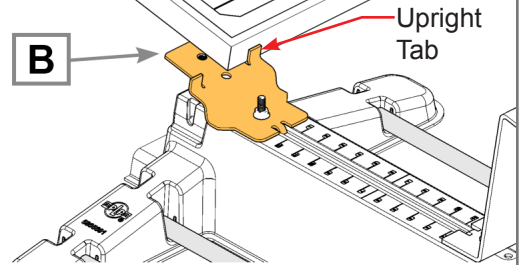

Adjust Tray position to a maximum 1.25" from Bracket Front Surface to Module Frame.

1.25" Maximum

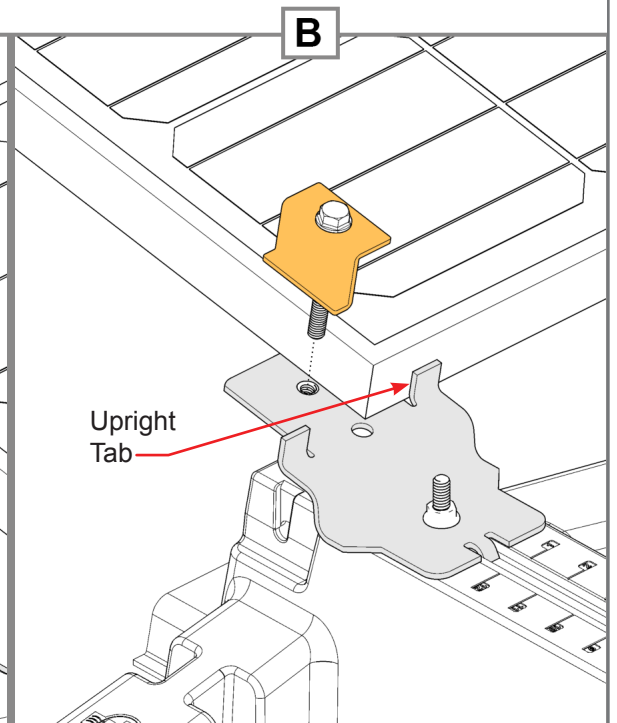

Install one End Clamp assembly into each Bracket. Ensure that the Module is square to the Trays and there are no visible gaps between Sleeve of End

Clamp Assembly and Module Frame (butt Frame up against the Sleeve/Bolt of End Clamp). Tighten the Bolt and **Torque to 15 ft.-lbs.**

6 Install Modules (cont.)

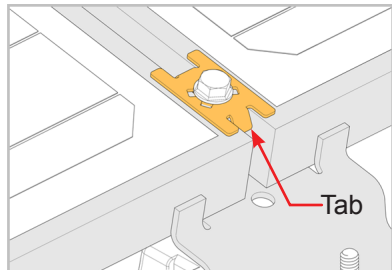
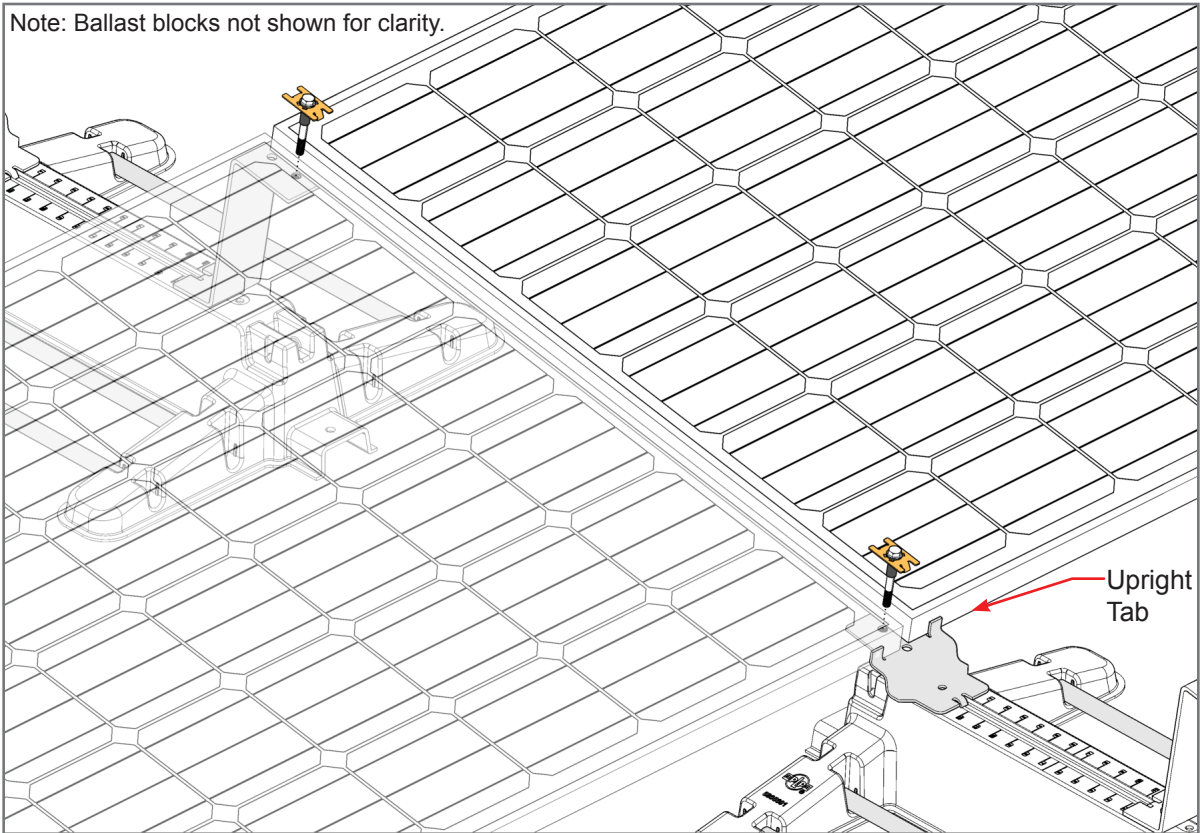

Install the AMP Clamp with its tabs between the two Modules, then push the Modules up against the tabs.

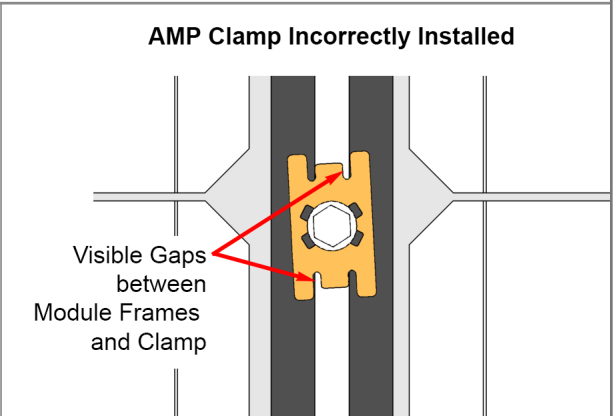
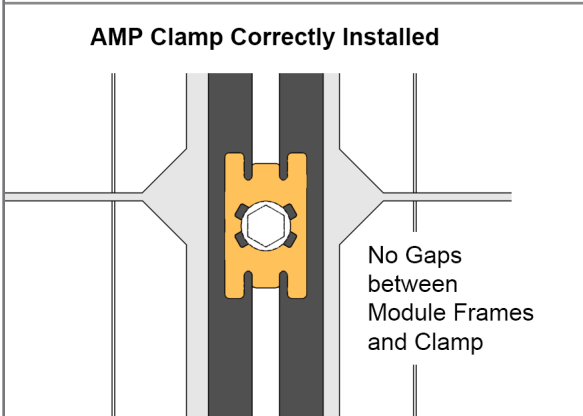

Install one AMP Clamp bonding Mid Clamp assembly into each Bracket. Ensure that the Clamp is square to the Module frames and there are no visible gaps. Tighten the Bolt and **Torque to 15 ft.-lbs.** Continue in the manner installing the remaining Modules.

Appendix A-1 Grounding/Bonding Path

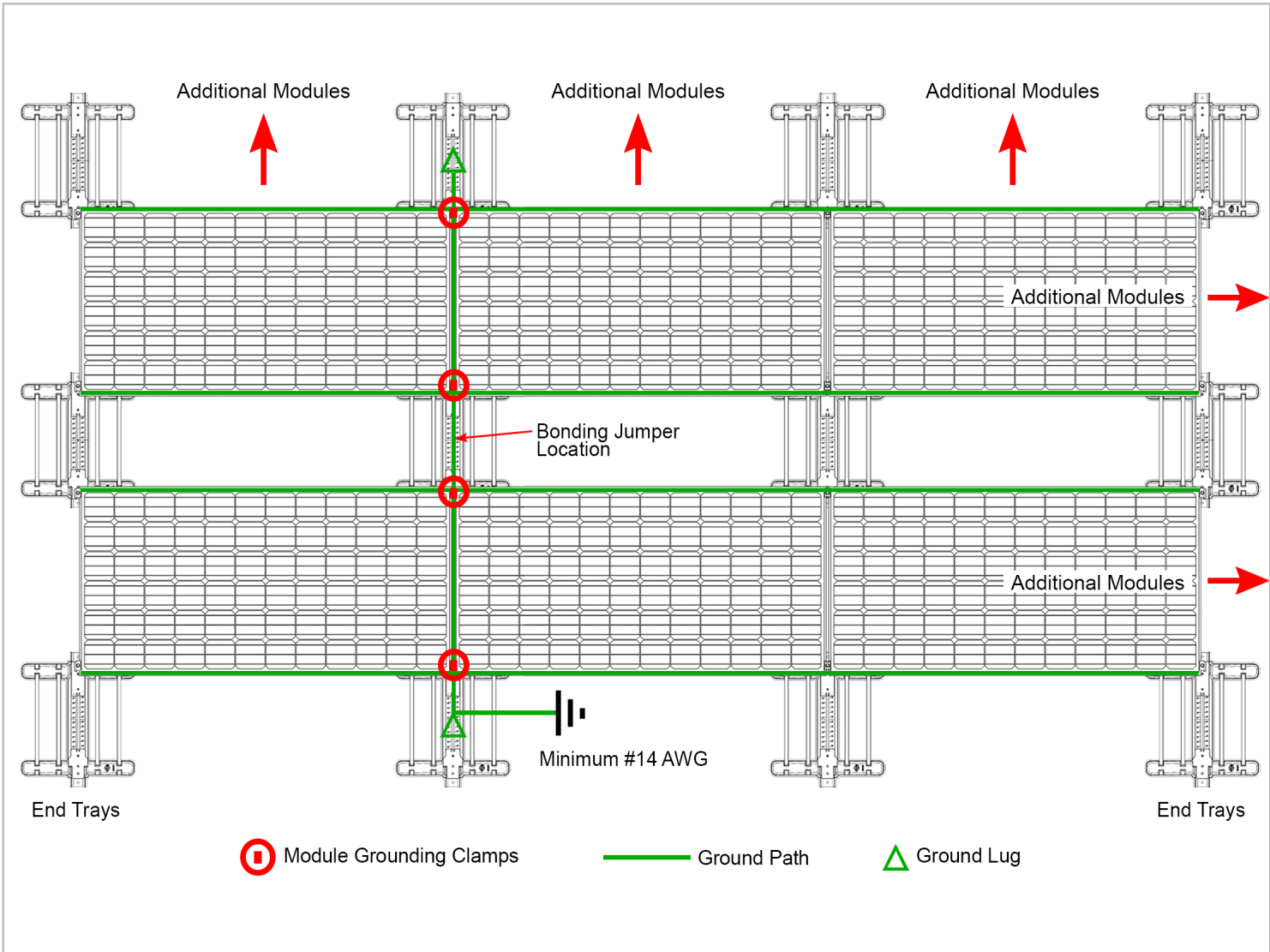

Appendix A-2 Install WEEB-LUG-8.0

IMPORTANT

Before installing, verify with the lug manufacturer for any updates or revisions to these lug installation instructions.

One of two mounting method locations may be used as shown at right.

Lug is suitable for use with 14-6AWG solid or stranded copper conductor when tightened to 5ft-lbs.

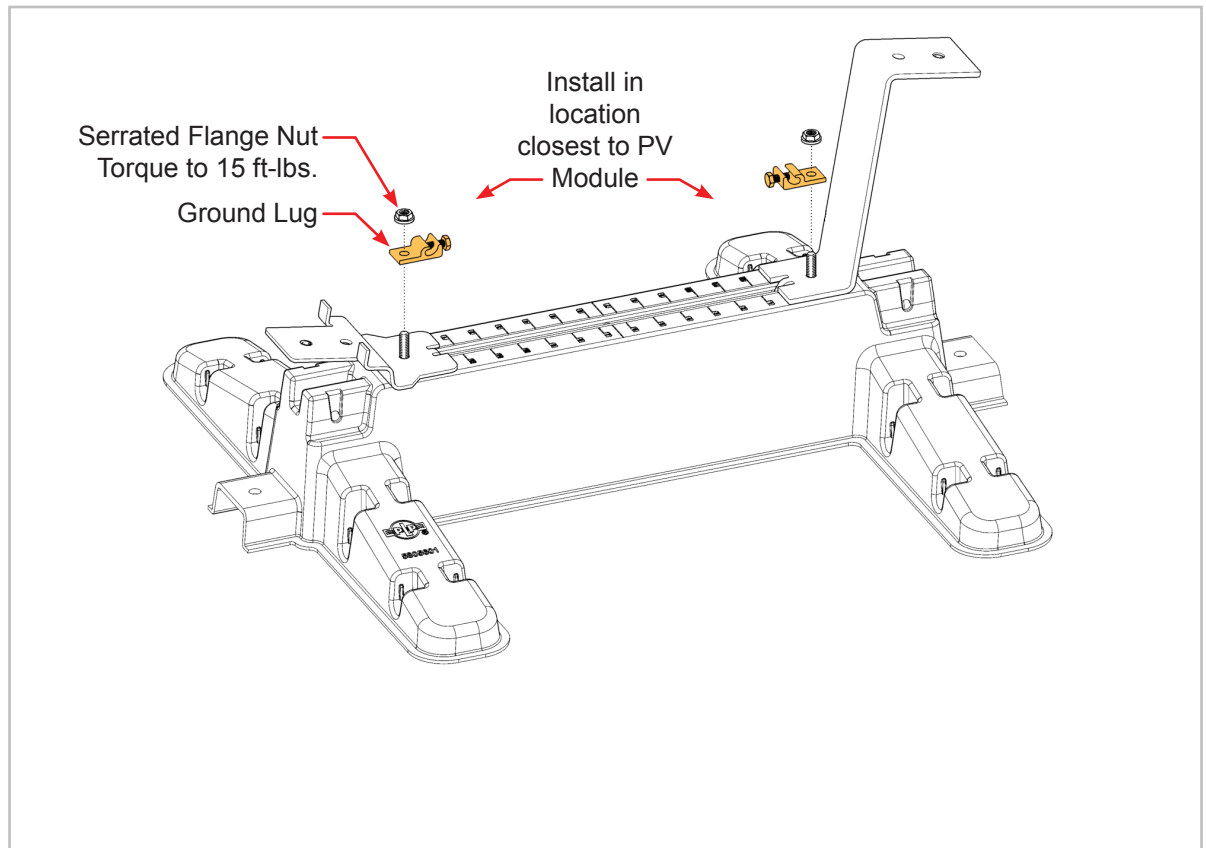

IMPORTANT NOTES

1. Before installing, verify with the lug manufacturer for any updates or revisions to these lug installation instructions. The instructions on this page only address the WEEB-LUG-8.0 as found within the manufacturers (Burndy) document number 50016572 Rev E.
2. For Proper Equipment Grounding Conductor (EGC) and Overcurrent Protection Device (OCPD) sizing, refer to NEC sections 250.66, 250.122 and 250.166.

Appendix A-3 Installing High Wind Ballast (not required on all systems)

NOTE

The High Wind Ballast Support Tubes and ballast are not required on all systems. See job specific project drawings for High Wind Ballast placement. Ballast Support Tubes are custom length per drawing requirements.

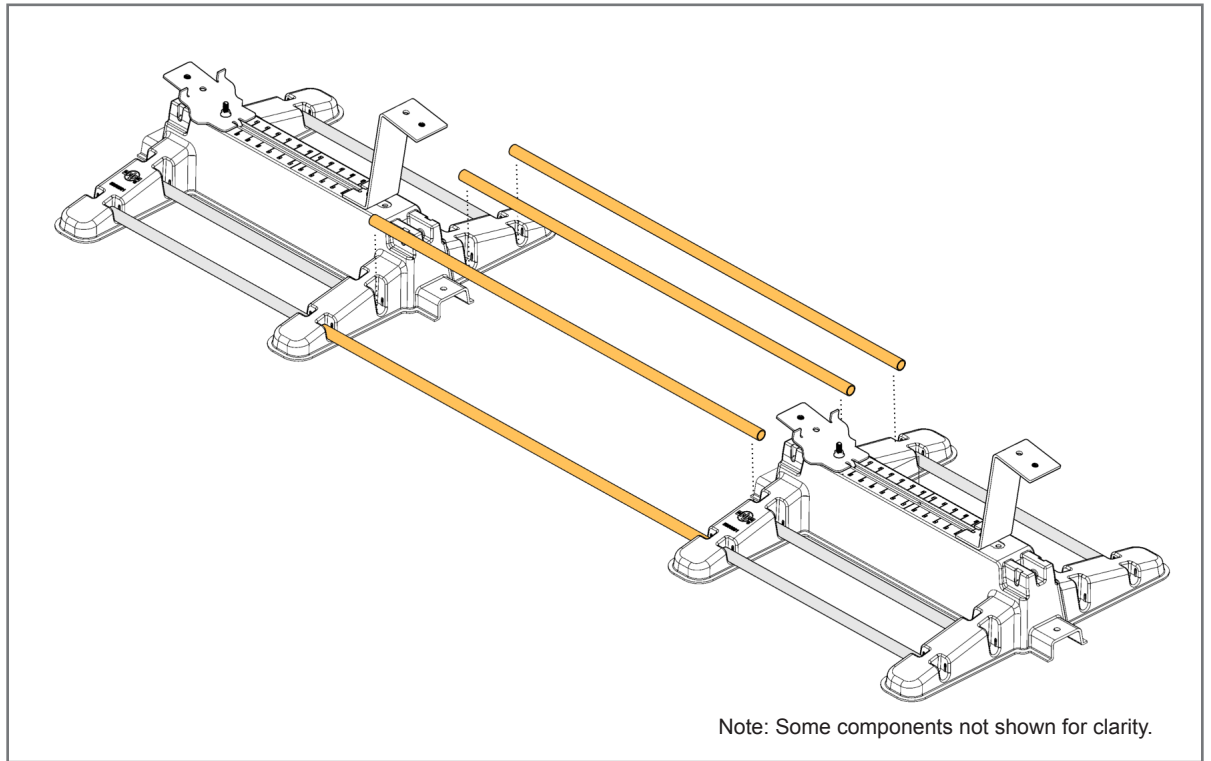

Install each of the four High Wind Ballast Support Tubes into their respective notches of the Tray.

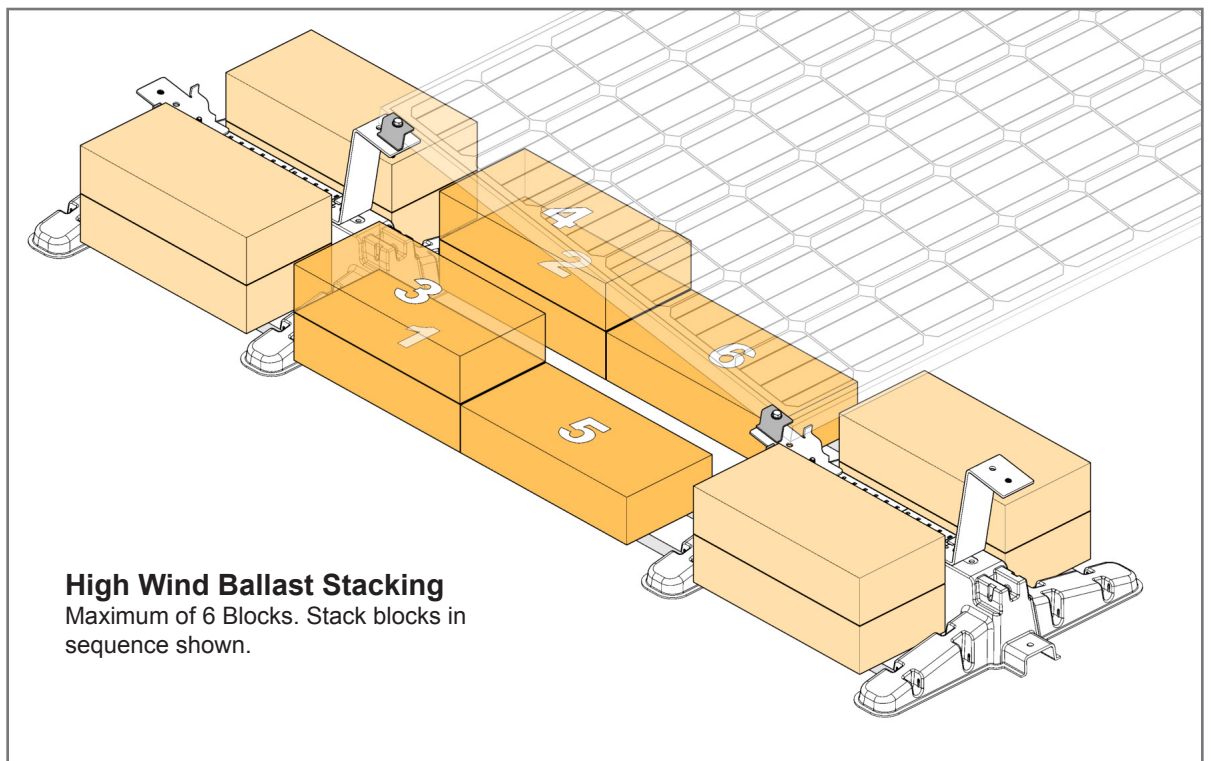

Stacking method for “High Wind” ballast shown above. This does not apply to all systems; only those installed in areas where higher winds require additional ballast.

Appendix A-4 Compatible Modules - these modules meet the UL2703 standard

This racking system may be used to ground and/or mount a PV module complying with UL 1703 only when the specific module has been evaluated for grounding and/or mounting in compliance with the included instructions.

Canadian Solar	40 mm	CS6P-250P, CS6P-255P, CS6P-260P, CS6P-260P-SD, CS6P-265P, CS6P-265P-SD, CS6P-270P
Hanwha	32 mm	Q.PRO BFR G4 G4.1 G4.3, Q.PLUS BFR G4.1, Q.PRO G4, Q.PLUS G4, Q.PRO L G4.1, Q.PLUS L G4.1 G4.2, Q.PEAK-G4.1 G4.1/MAX, Q.PEAK BLK G4.1, Q.PEAK L G4.2
Heliene	40 mm	60P-MIM
LG	35 mm	LG300N1C-G3, LG305N1C-G3, LG310N1C-G3
	36 mm	LG365N2W-B3, LG375N2W-B3
	40 mm	LG320N1C-G4, LG325N1C-G4, LG 335N1C-G4, LG340N1C-G4
	46 mm	LG375N2W-G4
Panasonic	35 mm	VBHNXXXSA16, VBHNXXXSA11
Solar World	31 mm	SW280 31mm
	33 mm	SW280, 285, 290, 295, 300 33 mm, SW 320 XL 33mm FR, SW 325 XL 33mm FR, SW 330 XL 33mm FR, SW 335 XL 33mm FR, SW 340 XL 33mm FR, SW 345 XL 33mm FR, SW 350 XL 33mm FR
Suntech	50 mm	STP270-24/Vd, STP275-24/Vd, STP280-24/Vd, STP285-24/Vd, STP290-24/Vd, STP295-24/Vd, STP300-24/Vd, STP305-24/Vd
Winaco	40 mm	WSP-XXXM6 PERC (285, 290, 295, 300, 305W), WST-XXXP6BF, WST-XXXP6SF

PV Modules Tested

Manufacturer	Model	Weight (lbs)	UL2703 Load Rating (psf)		
			Downward*	Upward	Slope
Canadian Solar	CS6P-xxxP	40.9	15	10	10
LG	LGxxxN2W-G4	44.7	15	10	10
Suntech	STPxxx-24/Vd	59.4	15	10	10
Solar World	SWxxx XL 33mm FR	39.6	15	10	10



Albuquerque Office
1700 Louisiana Blvd., Suite 130
Albuquerque, NM 87110

Corporate Headquarters
660 Beta Drive
Mayfield Village, OH 44143

Telephone: 800.260.3792
Fax: 505.889.3548
www.preformed.com
E-mail: info@plpsolar.com

© 2017 Preformed Line Products
PCN 042917-1
SP3448-1