



POWER RAIL™ – TWO-TIER TILT KIT

ASSEMBLY INSTRUCTIONS

step-by-step
assembly and installation

SAFETY CONSIDERATIONS

This application procedure is not intended to supersede any company construction or safety standards. This procedure is offered only to illustrate safe application for the individual. **FAILURE TO FOLLOW THESE PROCEDURES MAY RESULT IN PERSONAL INJURY OR DEATH.**

Do not modify this product under any circumstances, except where noted in this application procedure.

This product is intended for use by trained technicians only. **This product should not be used by anyone who is not familiar with, and not trained to use it.**

When working in the area of energized lines, extra care should be taken to prevent accidental electrical contact. Be sure to wear proper safety equipment per your company protocol.

For proper performance and personal safety, be sure to select the proper size PREFORMED™ product before application.

PREFORMED products are precision devices. To ensure proper performance, they should be stored in cartons under cover and handled carefully.

POWER RAIL™ – Two-Tier Tilt Kit

WARNING

Follow the procedures and precautions in these instructions carefully.

About these instructions:

- The instructions do not include any information on the selection or installation of attaching hardware to be mounted to the roof substrate or concrete foundation. For information on compatible roof attaching hardware, see our publication titled “POWER RAIL™ Design Guidelines”.
- Begin after all attaching hardware has been installed and secured to the roof substrate or concrete foundation.
- They are intended to be used by individuals with sufficient technical skills for the task. Knowledge and use of hand tools, measuring devices and torque values is also required.
- Included, are various Notes, Cautions, and Warnings that are intended to assist in the assembly process and/or to draw attention to the fact that certain assembly steps may be dangerous and could cause serious physical injury and/or damage to components. Follow the procedures and precautions in these instructions carefully.

For questions on a specific installation, please:

Contact us by Phone: 800-260-3792

Send an Email request: info@PLPSolar.com

Periodic Inspection

PLP recommends a periodic re-inspection to check for any loose components or any corrosion. If any loose components and any corrosion is found, the affected components are required to be replaced immediately, with the original mounting system manufacturer’s component parts.

Required Tools

- 3/4 inch wrench or socket for 1/2 inch hardware
- 1/2 inch wrench or socket for 5/16 inch hardware
- Torque wrench
- Ratchet wrench
- Ratchet extension bar
- Framing square
- Tape measure

Two-Tier Tilt Kit Main Components

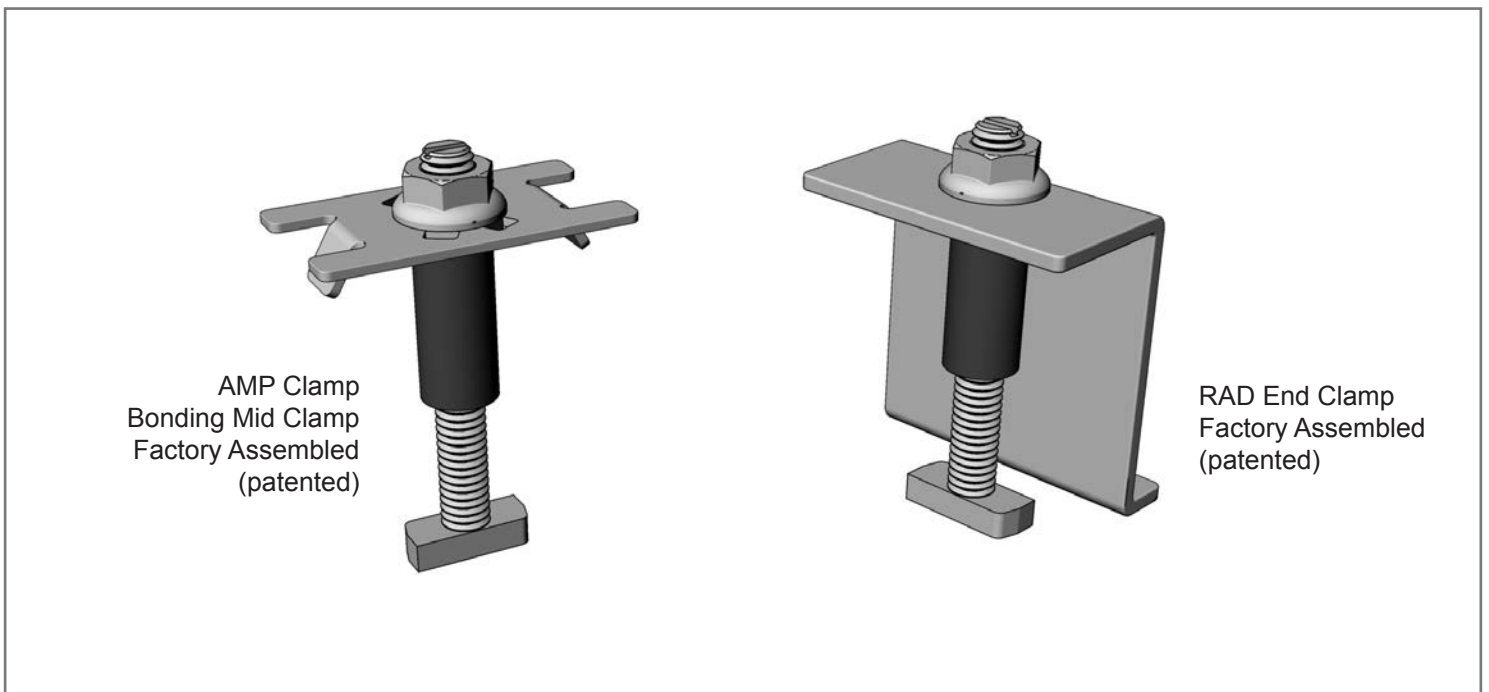
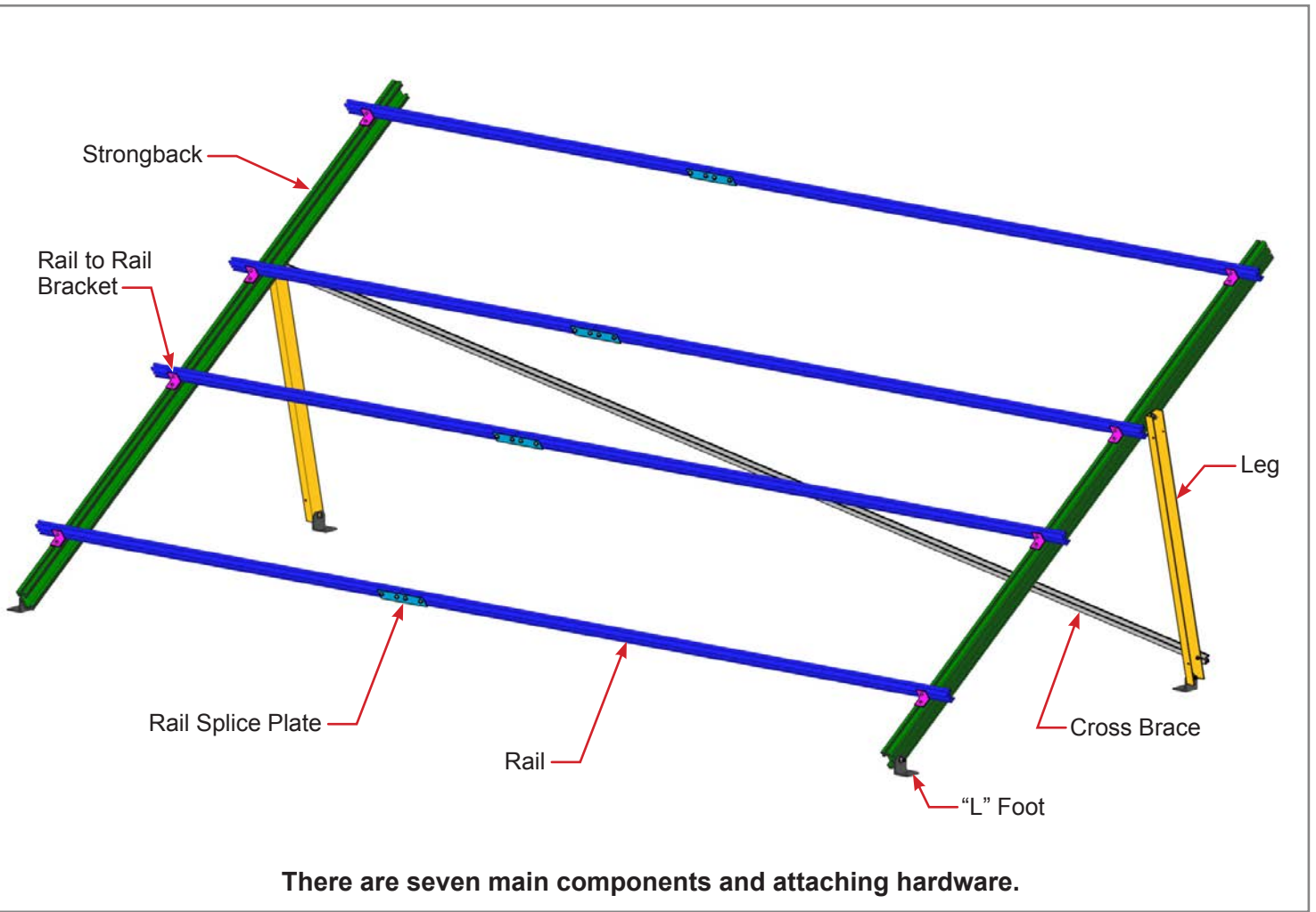

Spacing Calculations (16 Inch on Center Joists)

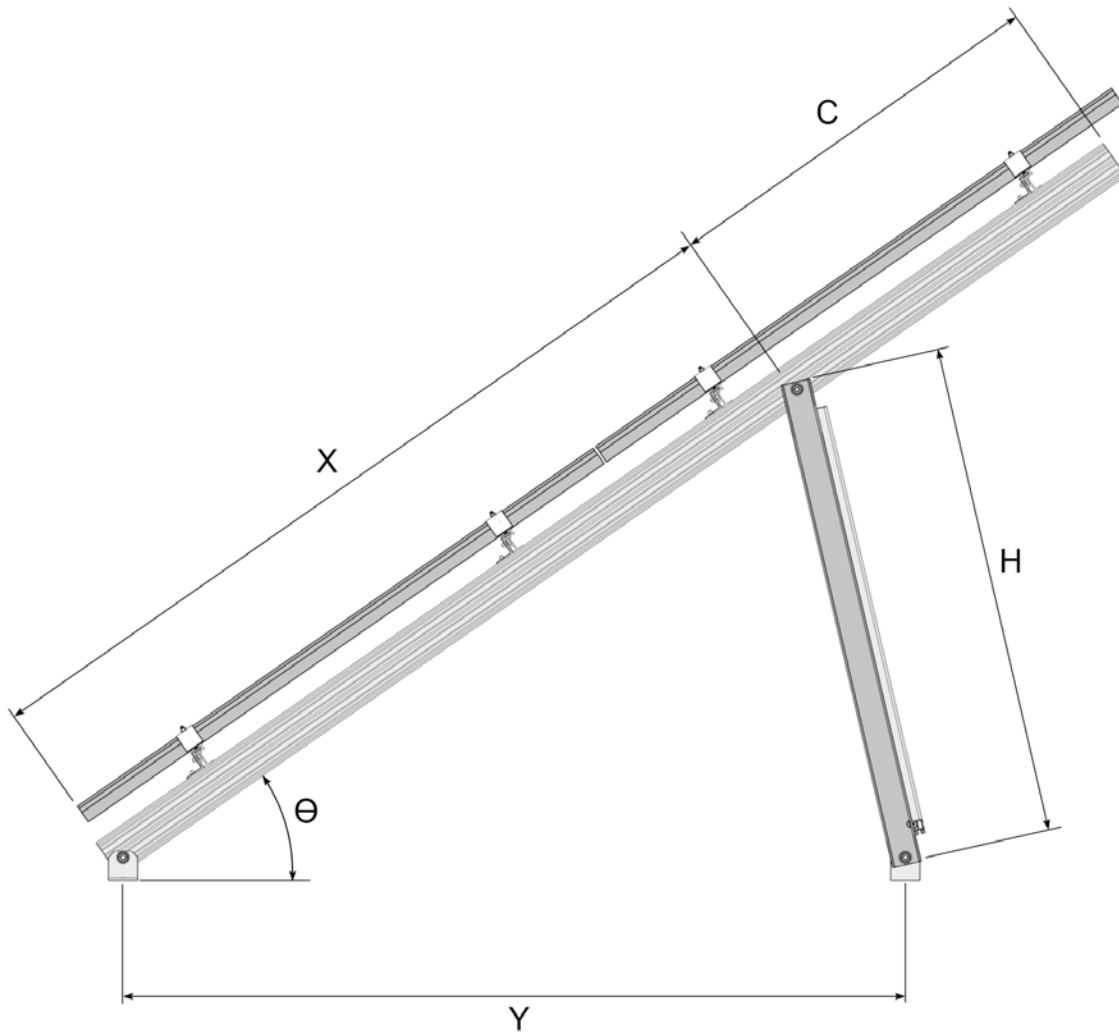

Module Type	Angle, θ (degrees)	Tilt Leg Length, H (in.)	Span Length, X (in.)	Cantilever Length, C (in.)	Foot Spacing, Y (in.)	Strongback Length, (in.)
60 Cell	15	23.3	84	42	80	126
	25	37.2	84	42	80	
	35	51	84	42	80	
	45	64.4	84	42	80	
72 Cell	15	26.4	100	50	96	150
	25	42.6	100	50	96	
	35	58.5	100	50	96	
	45	74	100	50	96	

1 Install the “L” Feet

NOTE

“L” Feet can be attached directly to the roof substrate with the proper hardware. See POWER RAIL Design Guidelines for more information.

Information on appropriate anchoring hardware is available on an individual product basis.

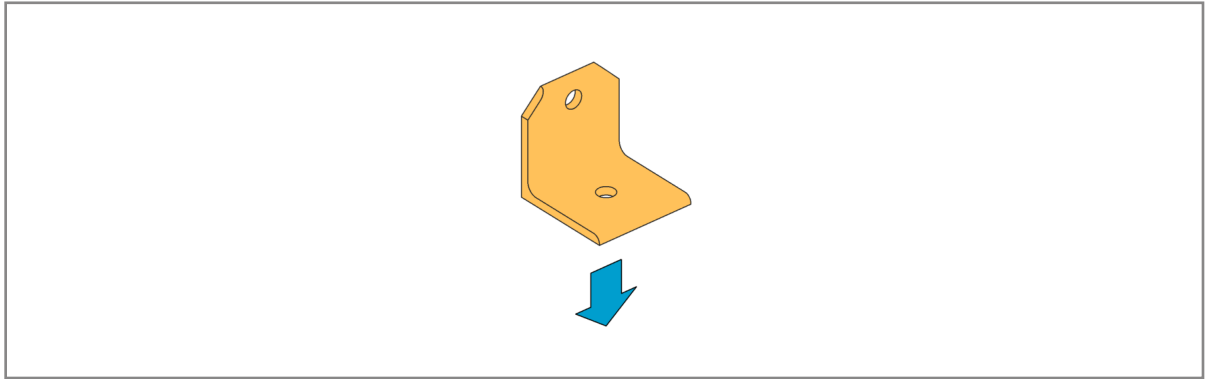

Secure the “L” foot to the site-specific anchoring device such as the foundation, roof structural member, or surface anchoring device per the device manufacturers’ instructions. “Site specific anchoring device”

means an appropriate surface attachment for the roof or substrate in which the Two-Tier Tilt Kit will be installed.

2 Measure and Mark the “L” Foot and the Leg Attachment Points on the Strongbacks

CAUTION

Span dimensions are a design specification. Consult the design manual to match these dimensions to site conditions. It’s important to use the unique span dimension specific to the install. Failure to do so could lead to excessive deflection and/or premature system failure.

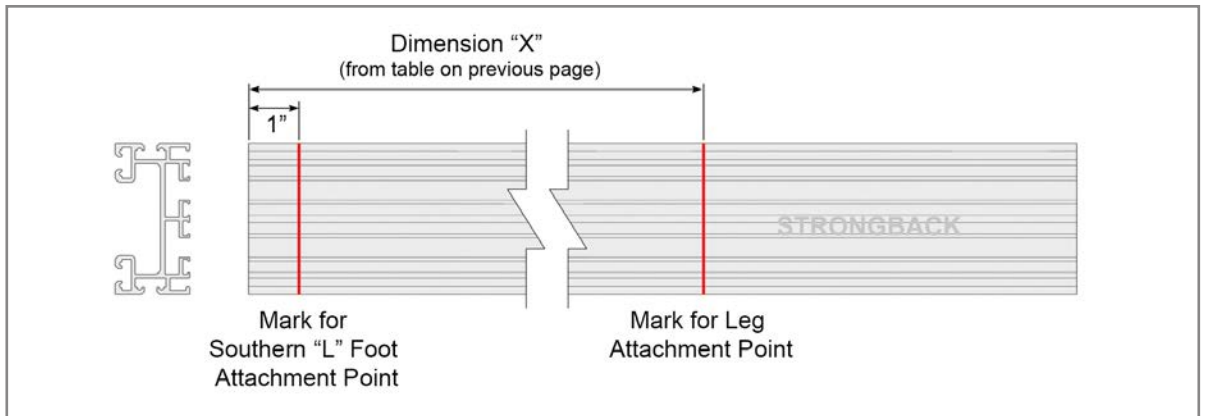

To ensure consistency and structural integrity, the attachment points of the “L” Feet and Legs must be in accordance with the above diagram and the “Spacing

Calculations” on page 3. Measure and mark each Strongback to establish attachment points for the “L” Foot and Leg.

3 Attach the Leg to the Strongback

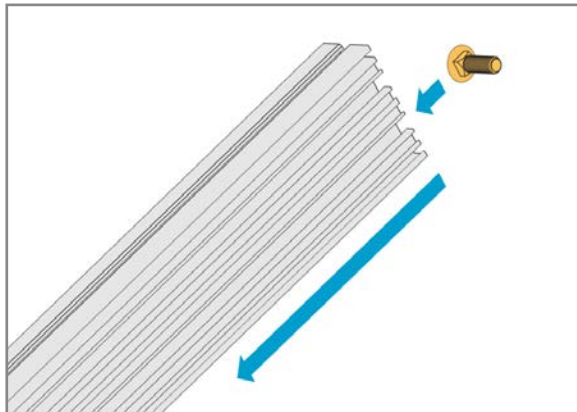

Insert a 1/2”-13 x 1-1/2” Carriage Bolt into channel of Strongback and slide it down to the previously made alignment mark. Install the Leg and secure with a 1/2”

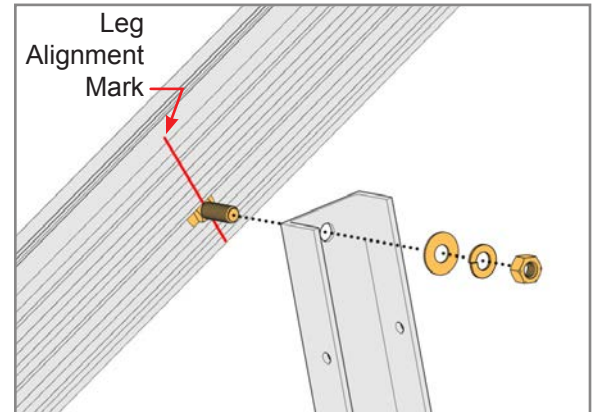

Flat Washer, Lock Washer and Nut. Tool tighten for now allowing the Leg to pivot/rotate as needed and align to the “L” Foot.

4 Attach the Strongback and then the Leg to their respective "L" Feet

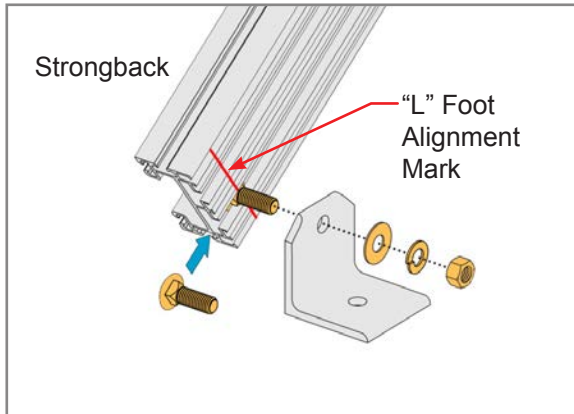

Insert a 1/2"-13 x 1-1/2" Carriage Bolt into the channel of the Strongback and align it to the previously made alignment mark. Secure with a 1/2" Flat Washer, Lock Washer, and Nut.

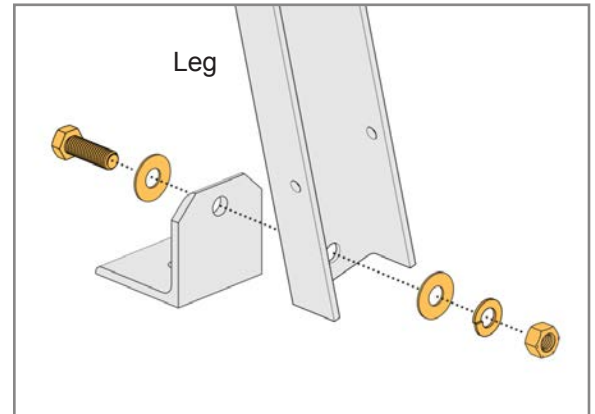

Secure the Leg to the "L" Foot with a 1/2"-13 x 1-1/2" Bolt, Flat Washers, Lock Washer, and Nut. Tool tighten for now, allowing for any adjustments in next step.

5 Check the "L" Foot and the Leg Alignment to the Marks on the Strongback and Torque Hardware

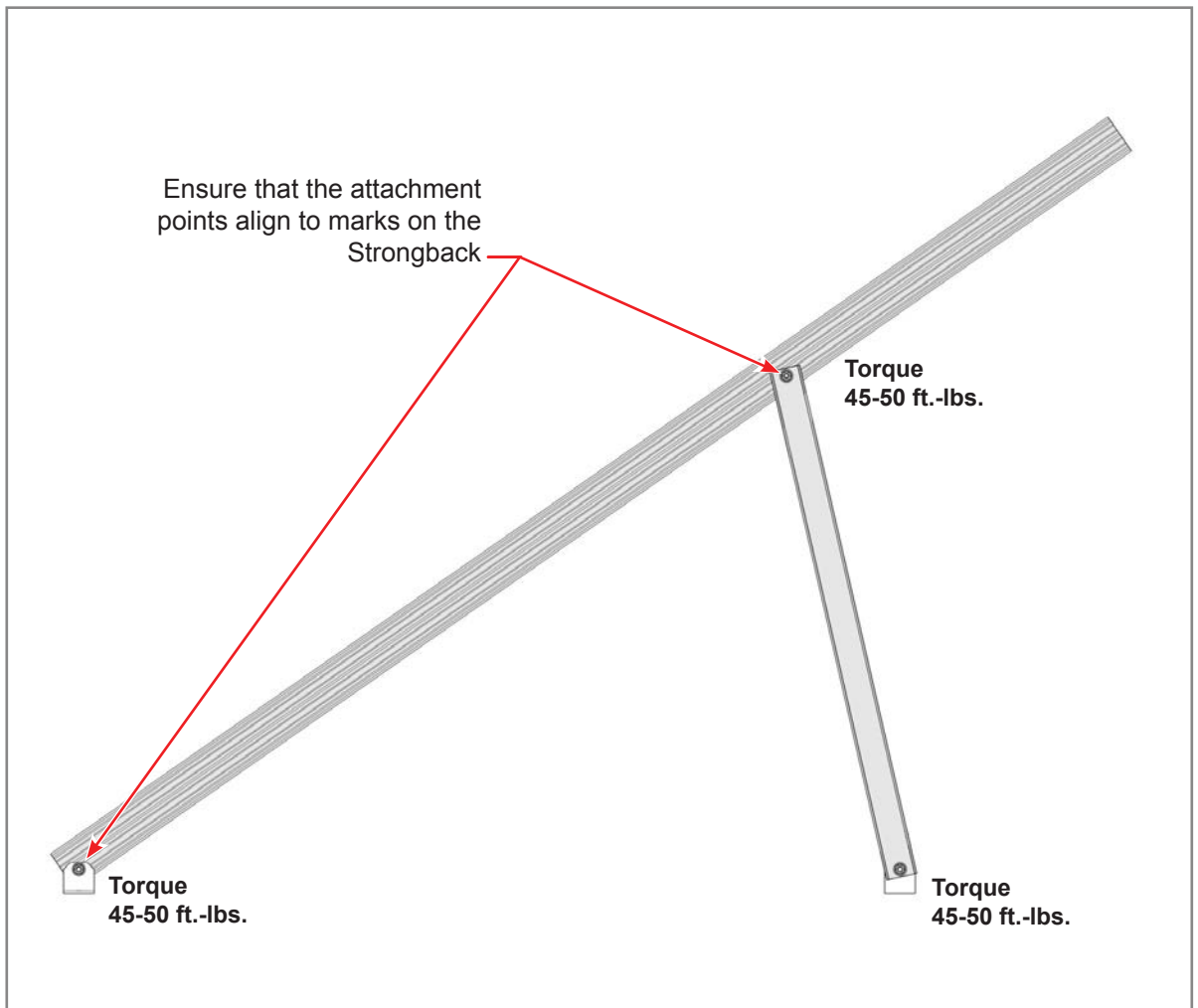

Ensure that the "L" Foot and the Leg align to the marks on the Strongback, then tighten the hardware and **torque to 45-50 ft.-lbs.**

6 Install the Cross Brace

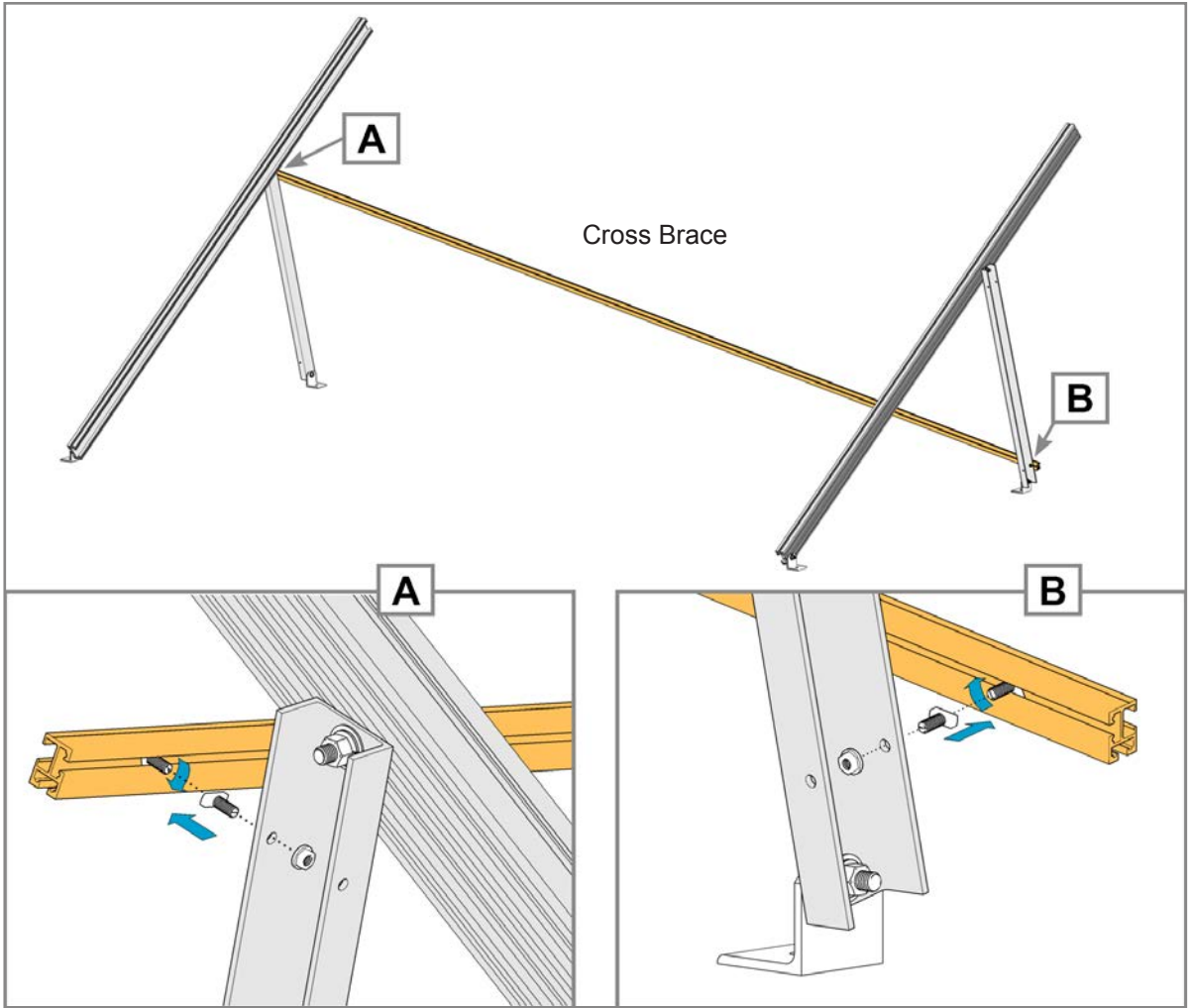

Insert a 5/16" x 1" Turn Bolt into the channel of the Cross Brace, and rotate 90-degrees to lock the Turn Bolt in place. Secure the ends of the Cross Brace to

the Legs with a 5/16" Flange Nut as shown above. Center the Cross Brace between the two attachment points. **Torque to 15 ft.-lbs.**

7 Install the Rail-to-Rail Brackets

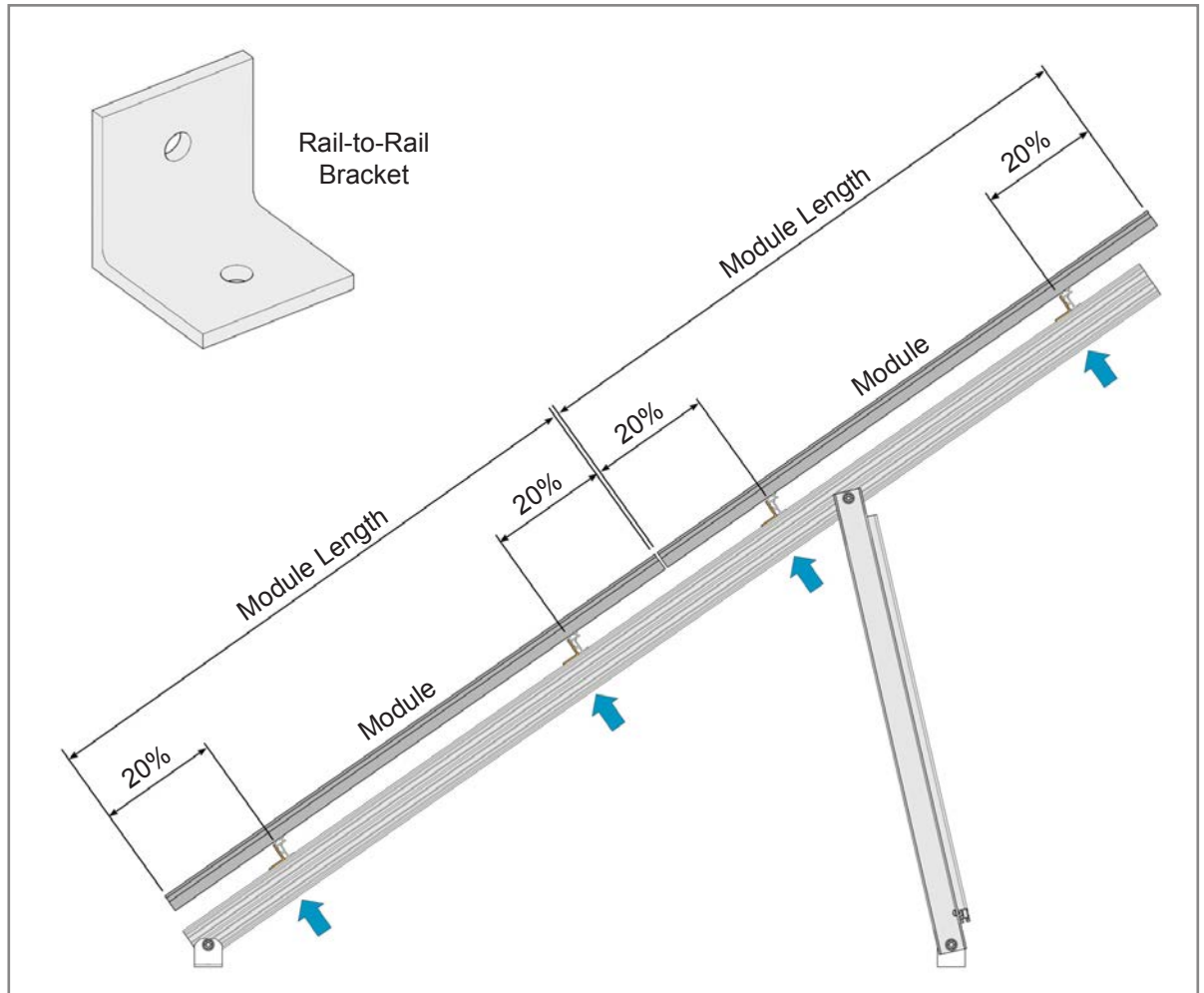

For Rail-to-Rail Bracket positioning, measure and mark their four locations along the Strongbacks. Span and placement of the Rail-to-Rail brackets along the Strongback is dependent on the module in use and its clamping locations. If the module manufacturer

has provided specific clamping locations, use those specifications; if none are specified by the manufacturer, use a factor of 20-percent of the module length to determine the N-S positions of the Rail-to-Rail Brackets. Measure and mark the Strongbacks.

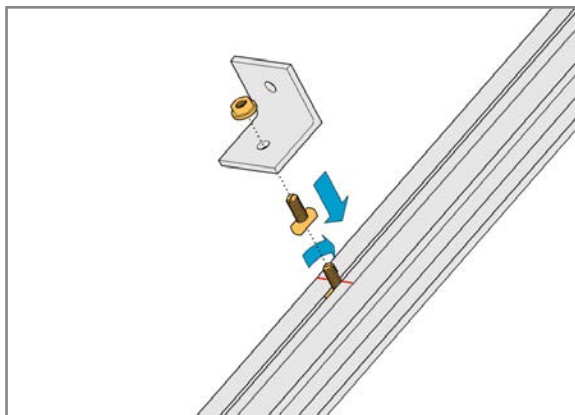

Insert a 5/16" - 18 x 3/4" Turn Bolt into the channel of the Strongback, aligning it to one of the previously made alignment marks, and rotate 90-degrees to lock the Turn Bolt in place. Secure the Rail-to-Rail Bracket with a 5/16" Flange Nut. **Torque to 15 ft.-lbs.**

8 Splicing the POWER RAIL with the Splice Plates (as needed)

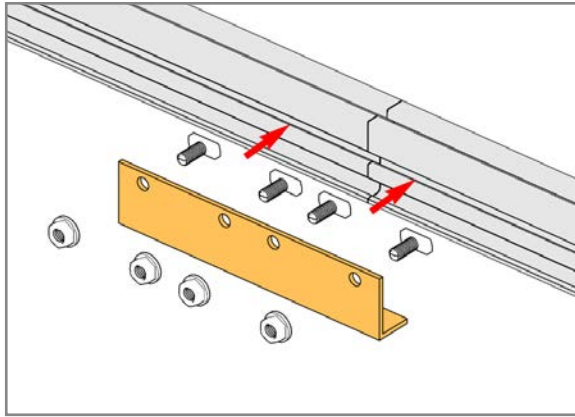

Splice Plates come in two configurations, 2-hole or 4-hole (above is a 4-hole). Insert 5/16" x 3/4" Turn Bolts into POWER RAIL and rotate 90-degrees to lock

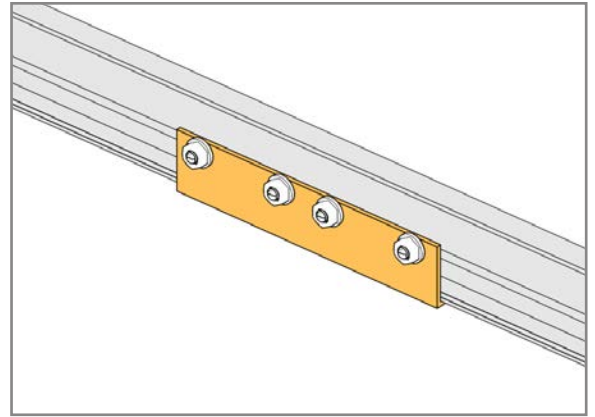

Turn Bolts in place. Align Splice Plate with center of splice and secure to POWER RAIL with 5/16" Flange Nuts. **Torque to 15 ft.-lbs.**

9 Install the POWER RAIL

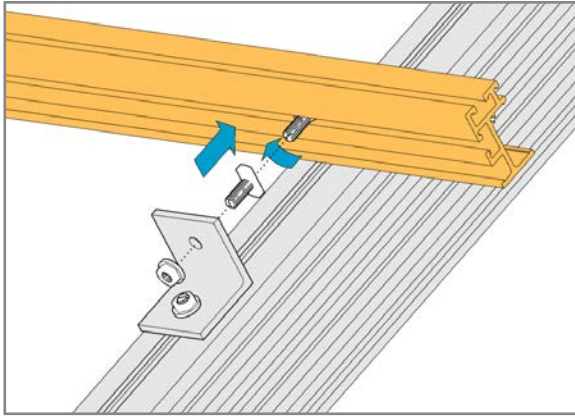

Insert a 5/16"x 3/4" Turn Bolt into the channel of the POWER RAIL, aligning it with the Rail-to-Rail Bracket. Rotate the Turn Bolt 90-degrees to lock it in place. Secure with a 5/16" Flange Nut. **Torque to 15 ft.-lbs.**

10 Install the Modules

CAUTION

This is a two person activity. In addition to the difficulties associated with working on a sloped rooftop, PV Modules are heavy. One person should hold and align the modules while a second person secures modules with the clamping hardware. Failure to do so could lead to serious personal injury and/or damaged components.

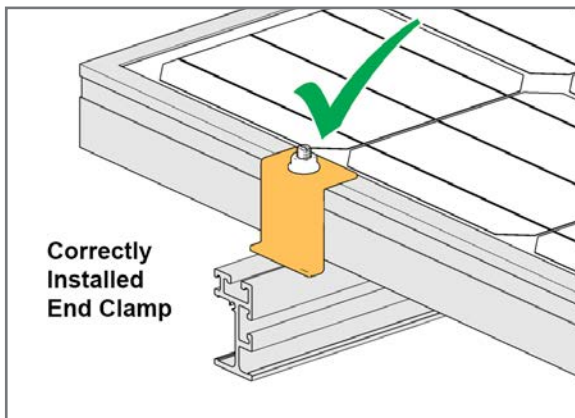

Correctly Installed End Clamp

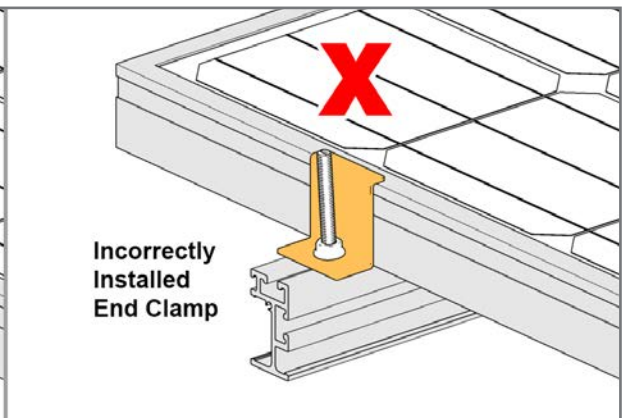

Incorrectly Installed End Clamp

The End Clamps must be installed as shown above left, not upside down as shown to the right.

10 Install the Modules (con't.)

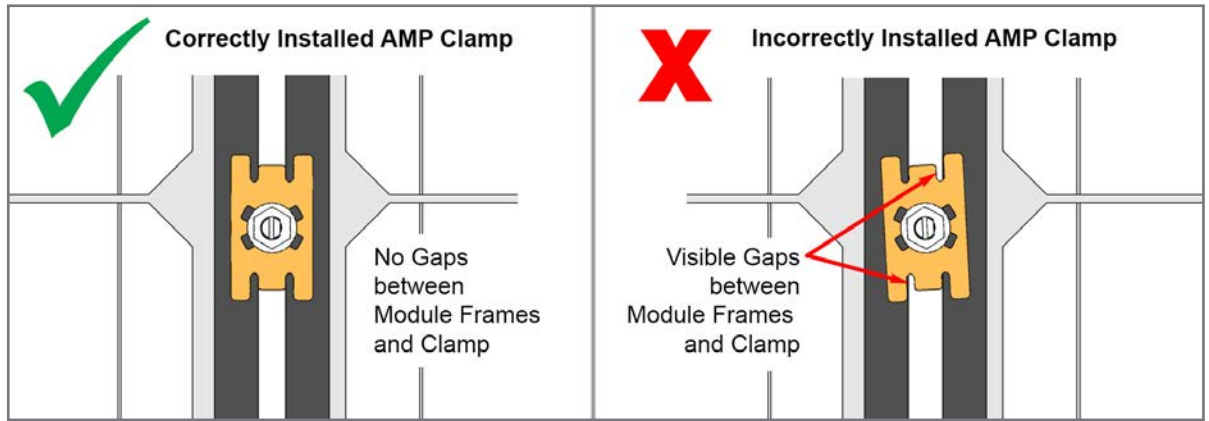

AMP Clamp bonding Mid Clamps must be installed as shown at above left and not as shown to the right. There cannot be any visible gaps between the bonding Mid Clamps and the module frames.

NOTE
 The RAD bolts used in the AMP-Clamps and the End Clamps must be locked into the channel by rotating them clockwise 90-degrees. Use the indicator slot on the threaded end to identify whether or not the bolt has been locked.

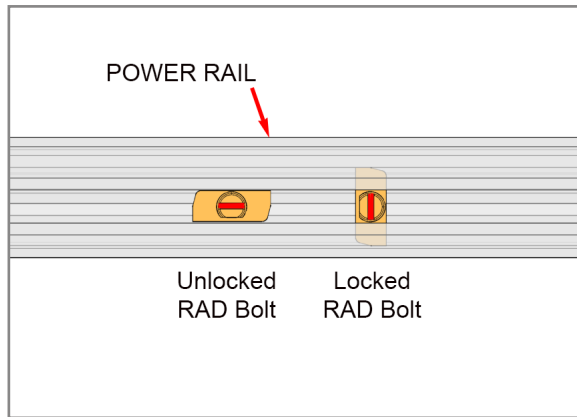

AMP Clamp bonding Mid Clamps are inserted into the POWER RAIL and positioned between the adjacent Modules. Insert the 5/16" RAD Bolt into the POWER

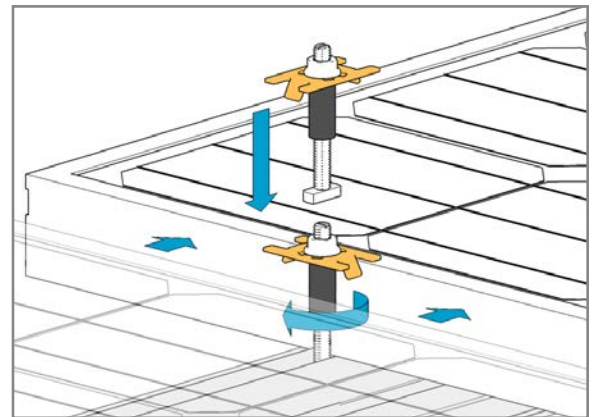

RAIL and rotate 90-degrees clockwise to lock the RAD Bolt within the POWER RAIL. Push the Modules against the AMP Clamp. Tighten the 5/16" Flange Nut. **Torque to 15 ft.-lbs.**

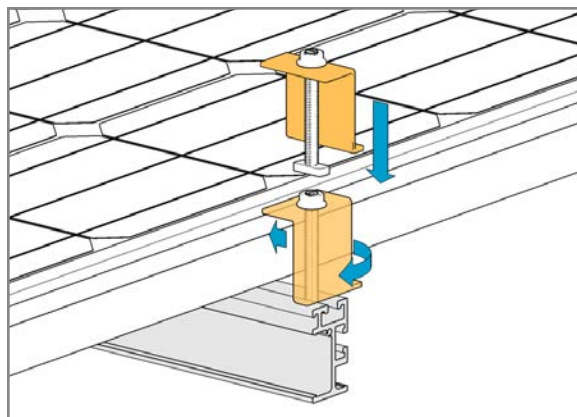

The RAD End Clamps are used on the outer Modules. Insert the 5/16" RAD Bolt into the POWER RAIL and rotate 90-degrees clockwise to lock the RAD Bolt within the POWER RAIL. Secure with a 5/16" Flange Nut. **Torque to 15 ft.-lbs.**



Corporate Headquarters
660 Beta Drive
Mayfield Village, OH 44143

Telephone: 800.260.3792
Fax: 440.442.8816
preformed.com
Email: info@plpsolar.com

© 2019 Preformed Line Products
SP3504