

Tilted (5° & 10°) Array

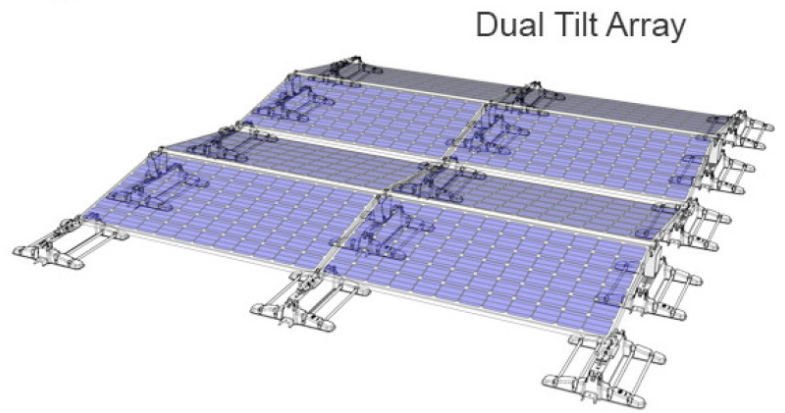

Dual Tilt Array

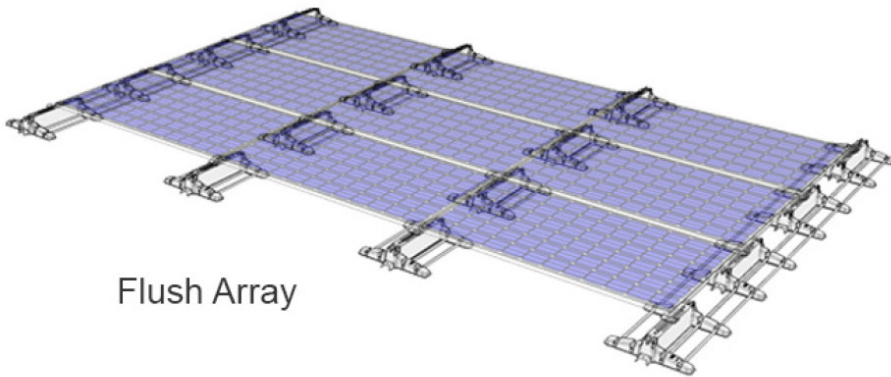

Flush Array

POWER MAX™ Accessories

Tilted (5° & 10°), Dual Tilt, & Flush Arrays

Installation Guide

SAFETY CONSIDERATIONS

This application procedure is not intended to supersede any company construction or safety standards. This procedure is offered only to illustrate safe application for the individual.

FAILURE TO FOLLOW THESE PROCEDURES MAY RESULT IN PERSONAL INJURY OR DEATH.

Do not modify this product under any circumstances, except where noted in this application procedure.

This product is intended for use by trained technicians only.

This product should not be used by anyone who is not familiar with, and not trained to use it.

When working in the area of energized lines, extra care should be taken to prevent accidental electrical contact. Be sure to wear proper safety equipment per your company protocol.

For proper performance and personal safety, be sure to select the proper size PREFORMED™ product before application.

PREFORMED products are precision devices. To ensure proper performance, they should be stored in cartons under cover and handled carefully.

- Installing Snake Trays - Cable Runs**
 - Tilted (5° & 10°) Array.....2
 - Dual Tilt Array.....2
 - Flush Array.....3
- Installing Ratchet P-Clamps - Conduit & Cable Runs**
 - Tilted (5° & 10°) Array.....3
 - Dual Tilt Array.....4
 - Flush Array.....4
- Installing PipeGuard - Conduit Support**
 - All Systems.....5
- Installing a Microinverter/Optimizer**
 - Tilted (5° & 10°) Array only.....5
- Installing Roof Protection Pads**
 - All Systems.....6
- Installing Deflectors**
 - Tilted (10°) Array only.....6
- Installing High Load Brackets**
 - Tilted (5° & 10°) Array and Dual Tilt Array.....7
- Installing Unistrut Rail - For Excessive Loads Only**
 - Tilted (5° & 10°) Array only.....8
- Installing Seismic Attachments**
 - All Systems.....10

Installing Snake Tray® - Cable Runs

Tilted (5° & 10°) Array - Utilizing PLP's Z-Bracket Kit

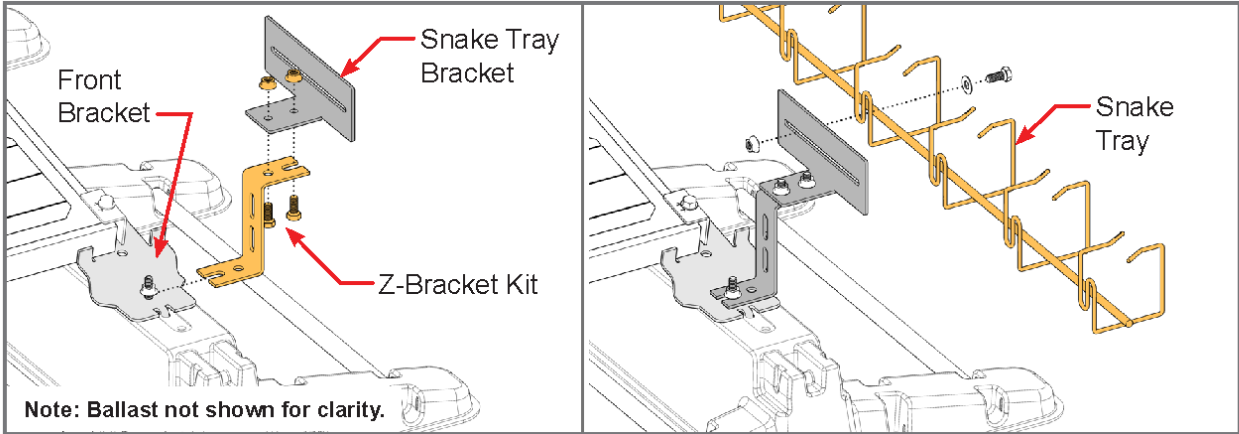

The Z-Bracket Kit may be secured to either the Front Bracket (as shown) or the Rear Bracket using the existing Flange Nut. Torque to 15 ft.-lbs.

Using the hardware provided in the Z-Bracket Kit, attach the Snake Tray Bracket to the Z-Bracket. Tighten securely.

Attach the Snake Tray to the Bracket using 5/16 x 3/4" Hex Screw, Flat Washer and Flange Nut. Tighten securely.

For more on Snake Tray see: snaketray.com

Dual Tilt Array - Utilizing PLP's Z-Bracket Kit

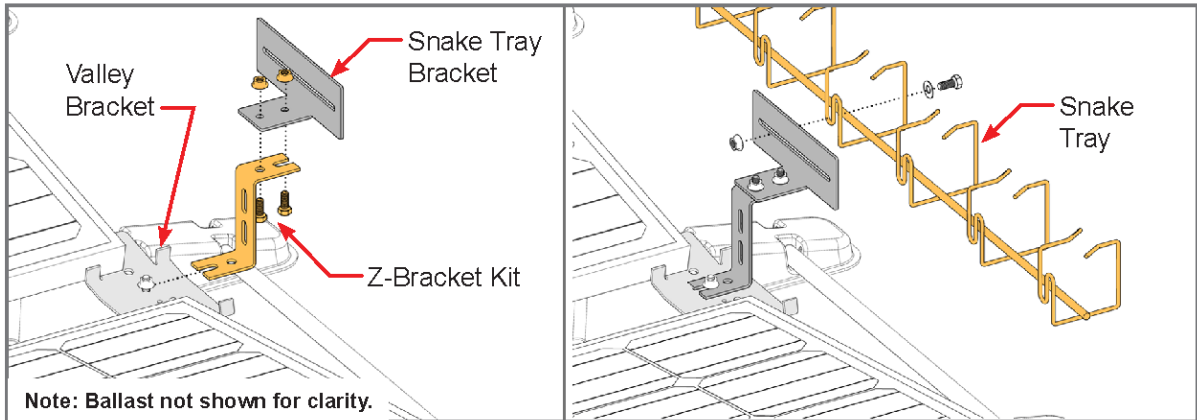

The Z-Bracket Kit is secured on top of the Valley Bracket as shown using the existing Flange Nut. Torque to 15 ft.-lbs. .

Using the hardware provided in the Z-Bracket Kit, attach the Snake Tray Bracket to the Z-Bracket. Tighten securely.

Attach the Snake Tray to the Bracket using 5/16 x 3/4" Hex Screw, Flat Washer and Flange Nut. Tighten securely.

For more on Snake Tray see: snaketray.com

Installing Snake Tray® - Cable Runs (cont.)

Flush Array

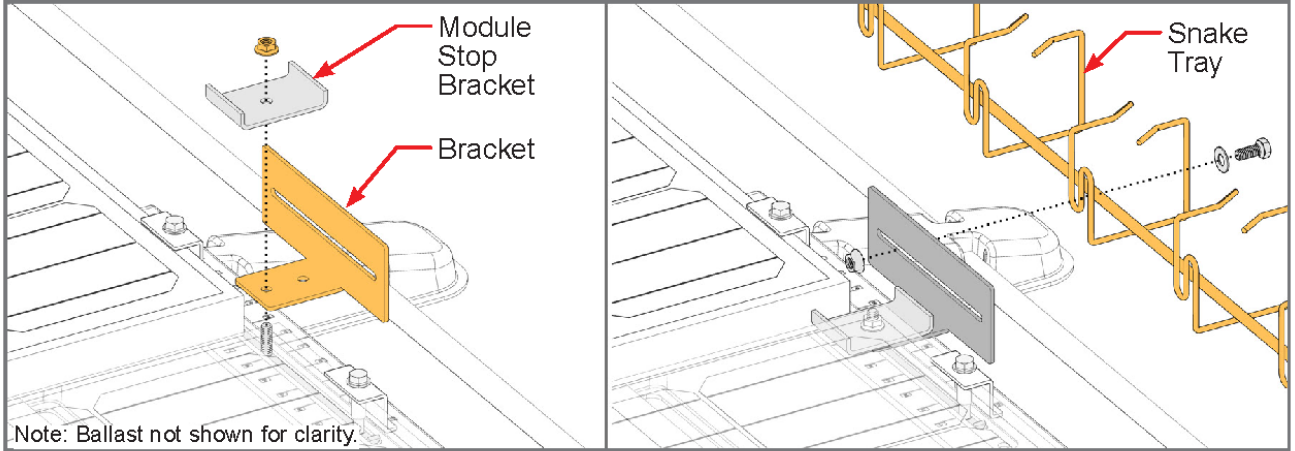

Note: Ballast not shown for clarity.

The Bracket is secured to the Tray, under the Module Stop Bracket using the existing Flange Nut. Torque to 15 ft.-lbs.

the Snake Tray to the Bracket using 5/16 x 3/4" Hex Screw, Flat Washer and Flange Nut. Tighten securely.

Using the hardware provided in the Bracket Kit, attach

For more on Snake Tray see: snake tray.com

Installing Ratchet P-Clamps - Conduit & Cable Runs

Tilted (5° & 10°) Array - Utilizing PLP's Z-Bracket Kit

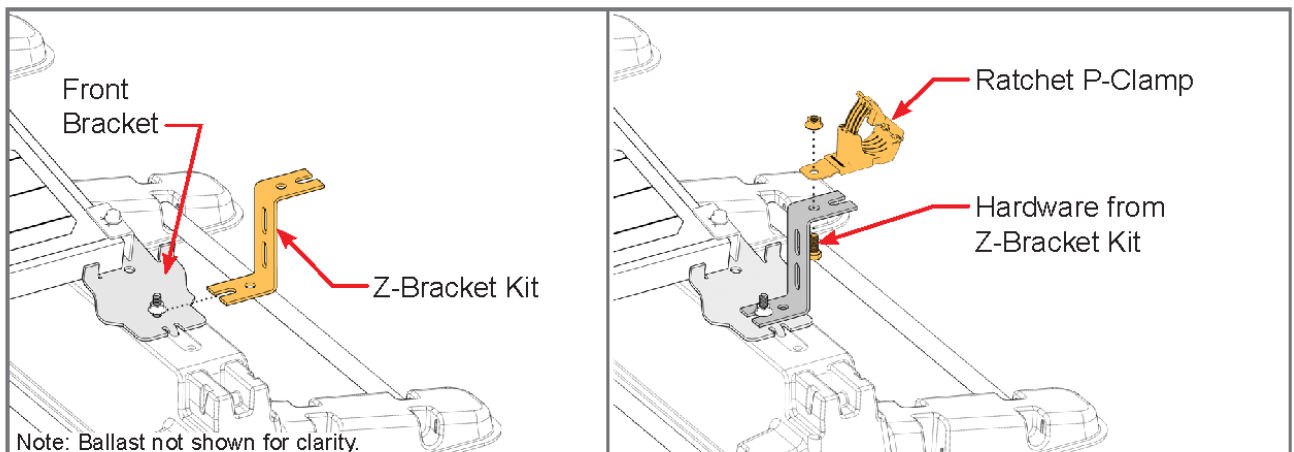

Note: Ballast not shown for clarity.

The Z-Bracket Kit may be secured to either the Front Bracket (as shown) or the Rear Bracket using the existing Flange Nut. Torque to 15 ft.-lbs.

Using the hardware provided in the Z-Bracket Kit, attach the Ratchet P-Clamp to the Z-Bracket. Tighten securely.

For more on Ratchet P-Clamps see: hellermannityton.us

Installing Ratchet P-Clamps - Conduit & Cable Runs (cont.)

Dual Tilt Array - Utilizing PLP's Z-Bracket Kit

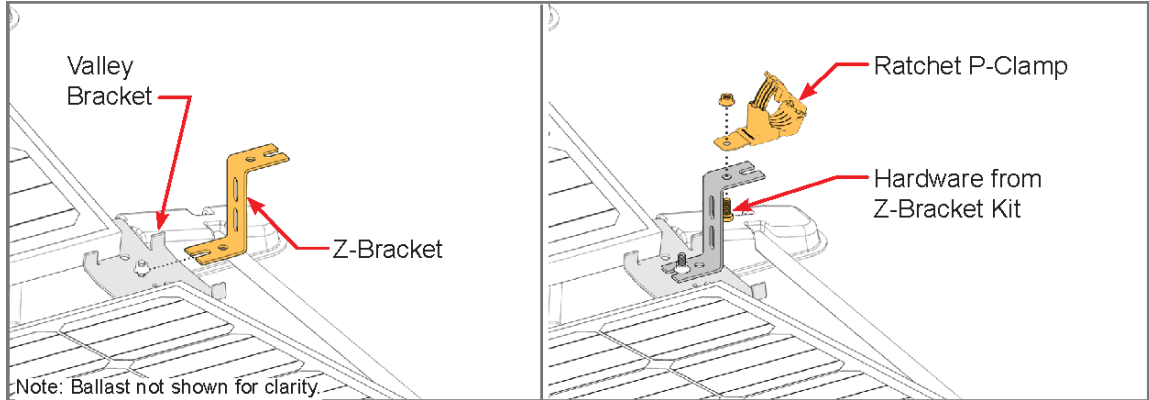

The Z-Bracket Kit is secured on top of the Valley Bracket as shown using the existing Flange Nut. **Torque to 15 ft.-lbs.**

Using the hardware provided in the Z-Bracket Kit, attach the Ratchet P-Clamp to the Z-Bracket.

Tighten securely.

For more on Ratchet P-Clamps see: hellermannityton.us

Flush Array - Utilizing PLP's Z-Bracket Kit

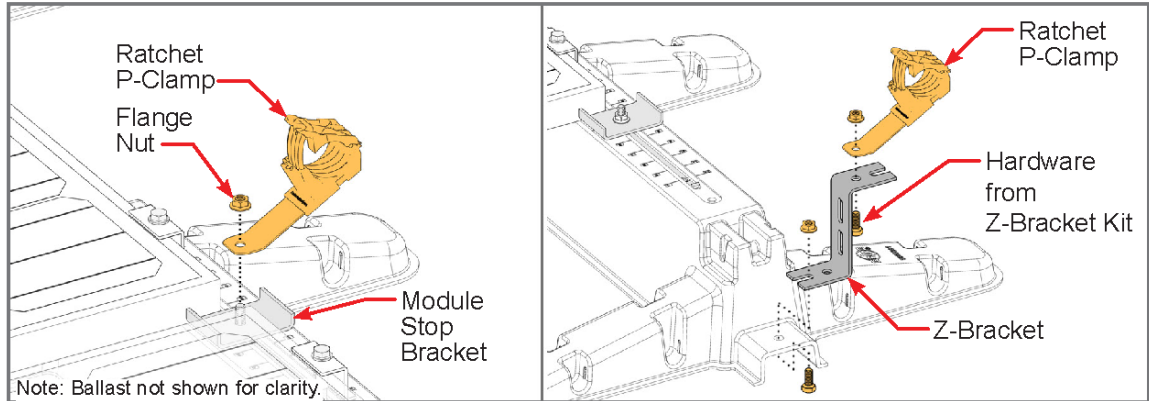

Two options are available for attaching the Ratchet P-Clamp, either to the Module Stop Bracket (above left) or the Tray (above right).

For the Tray attachment, use the hardware provided in the Z-Bracket Kit. Secure the Z-Bracket to the Tray and then secure the Ratchet P-Clamp to the top of the Z-Bracket. **Torque to 15 ft.-lbs.**

If attaching to the Module Stop Bracket, secure the Ratchet P-Clamp using the existing Flange Nut. **Torque to 15 ft.-lbs.**

For more on Ratchet P-Clamps see: hellermannityton.us

Installing PipeGuard - Conduit Support

NOTE

The use of a compatible separator sheet is required between PipeGuard and PVC roofing membranes. Consult roof membrane manufacturer for specific requirements.

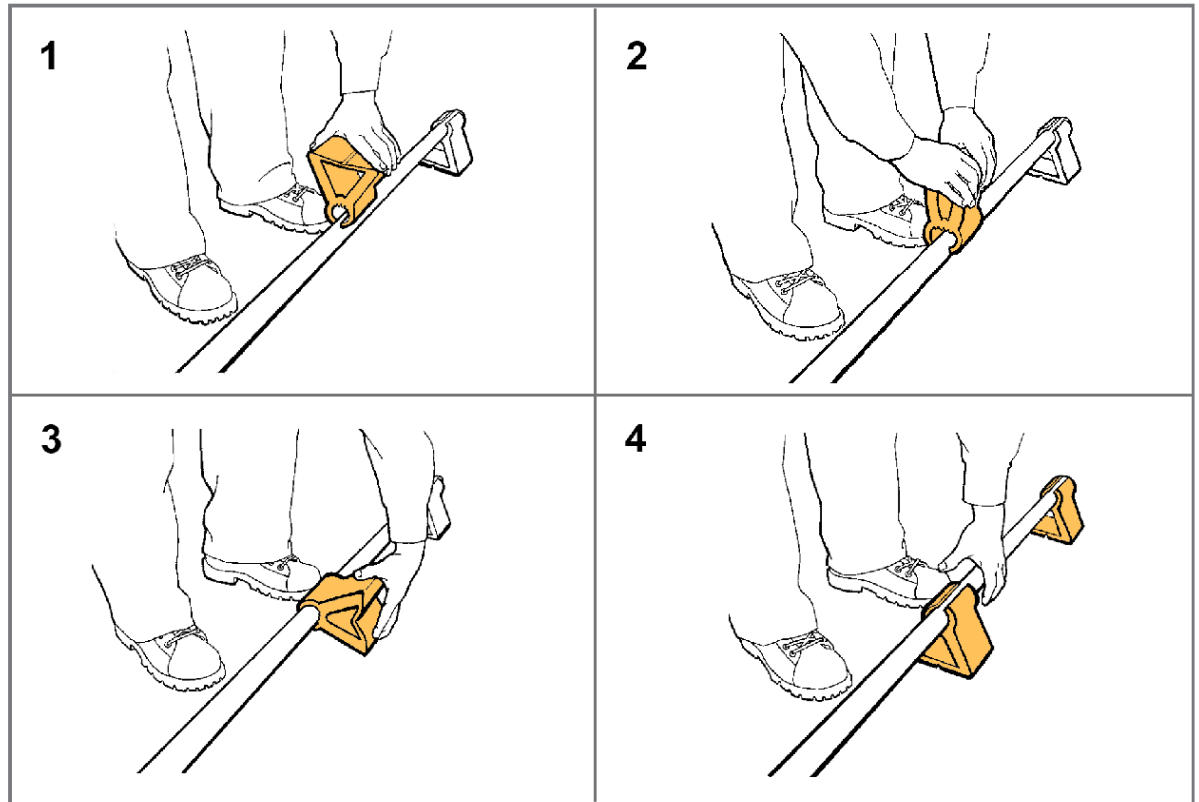

1. Hold the PipeGuard in its desired location along the conduit.
2. Squeeze the bottom of the PipeGuard, to open its clamp and accept the conduit. Press clamp portion onto conduit.
3. Rotate the PipeGuard into position under the conduit.
4. Let the PipeGuard rest on the roof surface.

Spacing Placement:

- Every 10 ft. (3.05m) for 2" (50mm) pipes or larger.
- Every 8 ft. (2.44m) for 1.5" (40mm) pipes.
- Every 6 ft. (1.83m) for 1" (25mm) pipes or smaller.

Place at every union, junction and source.

For more on PipeGuard see: omgroofing.com

Installing a Microinverter/Optimizer - Tilted (5° & 10°) Array only

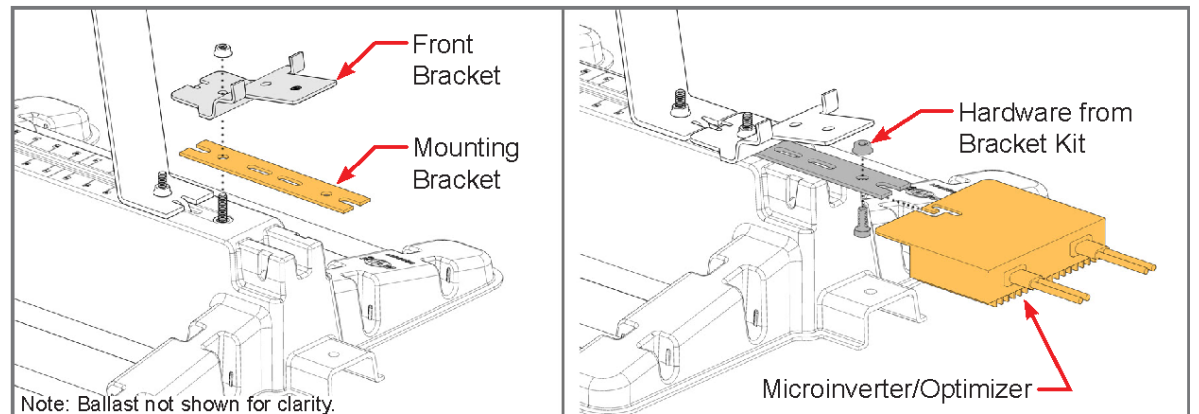

Attach the Mounting Bracket under the Front Bracket using the existing Flange Nut. **Torque to 15 ft.-lbs.**

Using the hardware provided in the Mounting Bracket Kit, attach the Microinverter/Optimizer to the underside of the Mounting Bracket. Tighten securely.

Installing Roof Protection Pads - All Systems

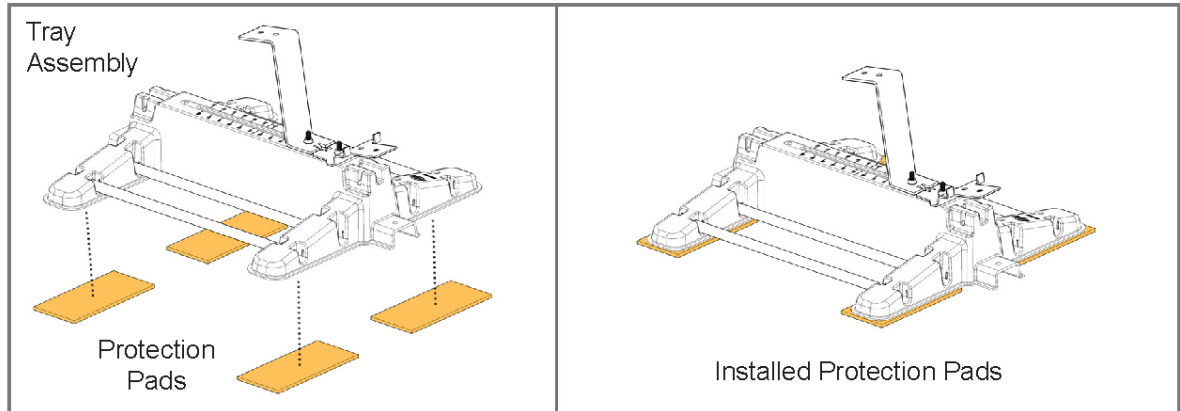

Use four Protection Pads per Tray Assembly, placing one Pad under each of the four Tray legs as shown.

Installing Deflectors - Tilted (10°) Array Only

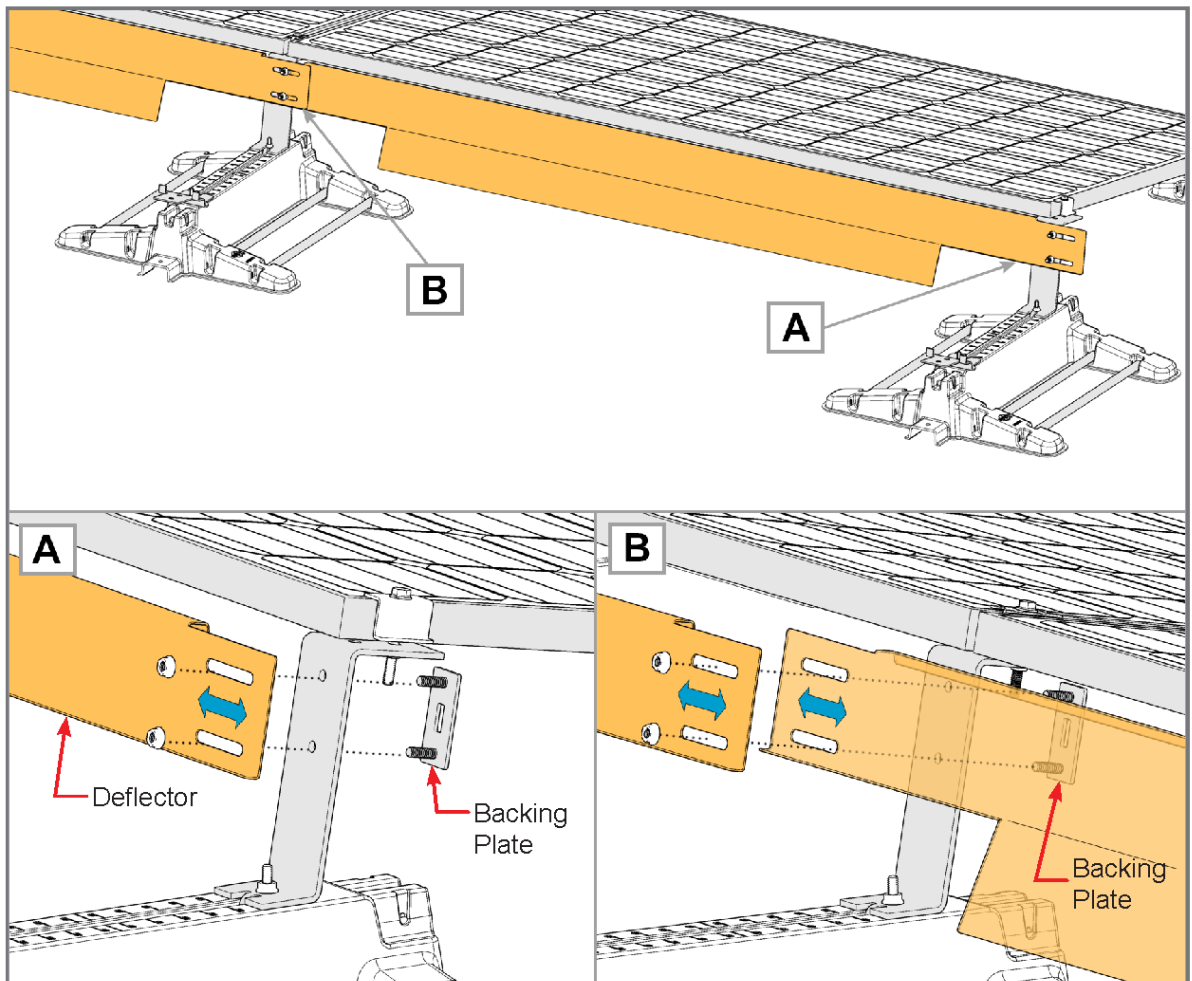

Insert the Backing Plate through the Back Bracket and the Deflector, thread on 5/16" Flange Nuts. Adjust the Deflector from side-to-side as needed then tighten the Flange Nuts. **Torque to 15 ft.-lbs.**

Insert the Backing Plate through the Back Bracket and the overlapping Deflectors. Thread on 5/16" Flange Nuts. Adjust the Deflectors from side-to-side as needed then tighten the Flange Nuts. **Torque to 15 ft.-lbs.**

Installing High Load Brackets - Tilted (5° & 10°), and Dual Tilt Array

NOTE

High Load Brackets are used in those areas where heavy snow loads or other conditions require additional Module support.

Install two High Load Brackets for each set of Modules. Place one Bracket under the lower (as shown) and one under the upper edge of each set of two Modules.

1. Orient the High Load Bracket as shown, aligning its notches with the upright tabs of the Module Bracket.
2. Install the Modules and the AMP™ Clamp per Assembly Instructions, securing High Load Bracket in place underneath the Modules.

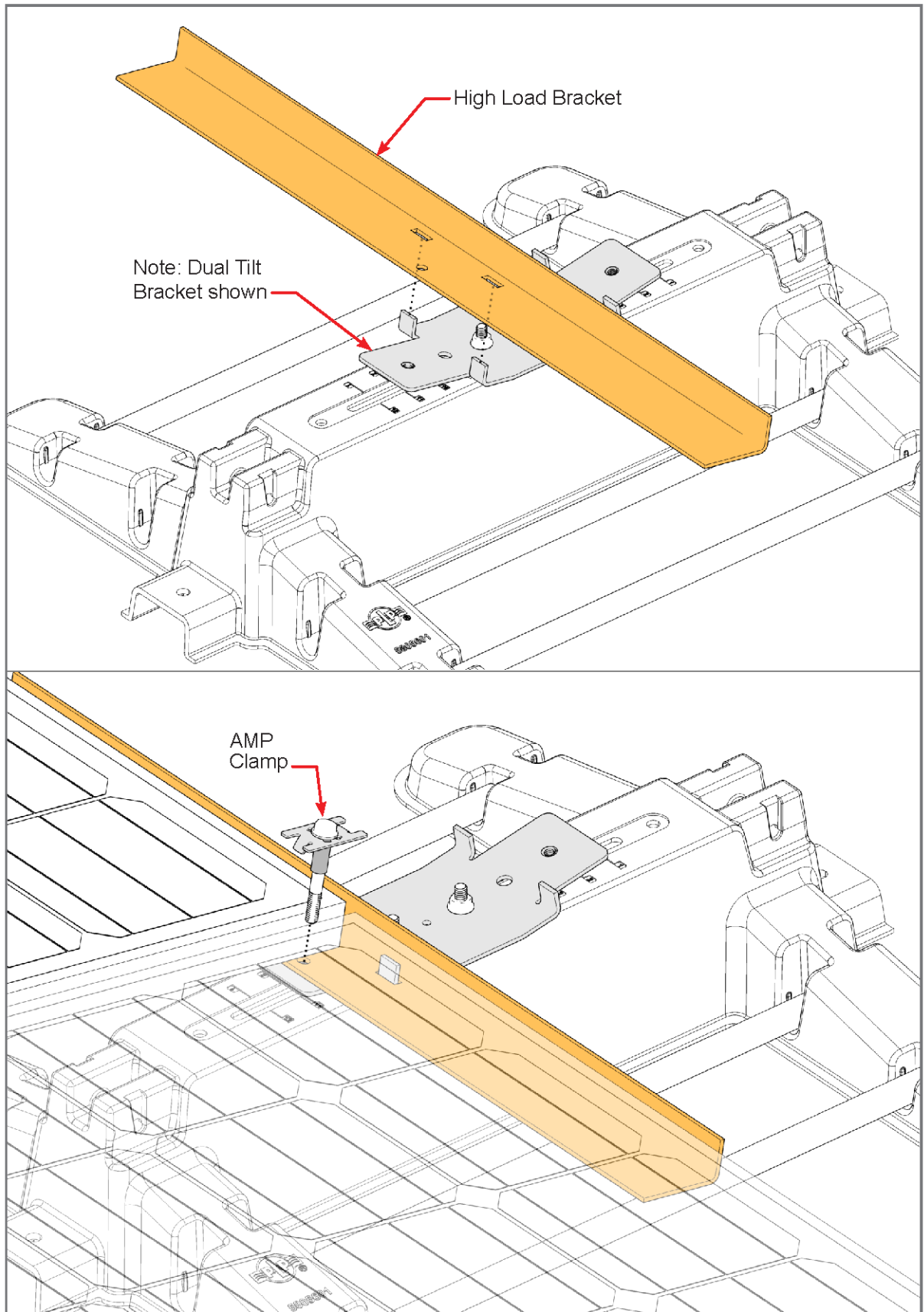

Installing Unistrut Rails - Tilted (5° & 10°) Array only

NOTE

Unistrut Rails are used where design loads are in excess of 30 psf (650/lbs/module).

Unistrut Rails are only needed on Tilted 5° & 10° systems with excessive loads.

Dual Tilt systems utilize a “shared Peak Bracket” which prevents any outside edge rows from slipping under excessive loads.

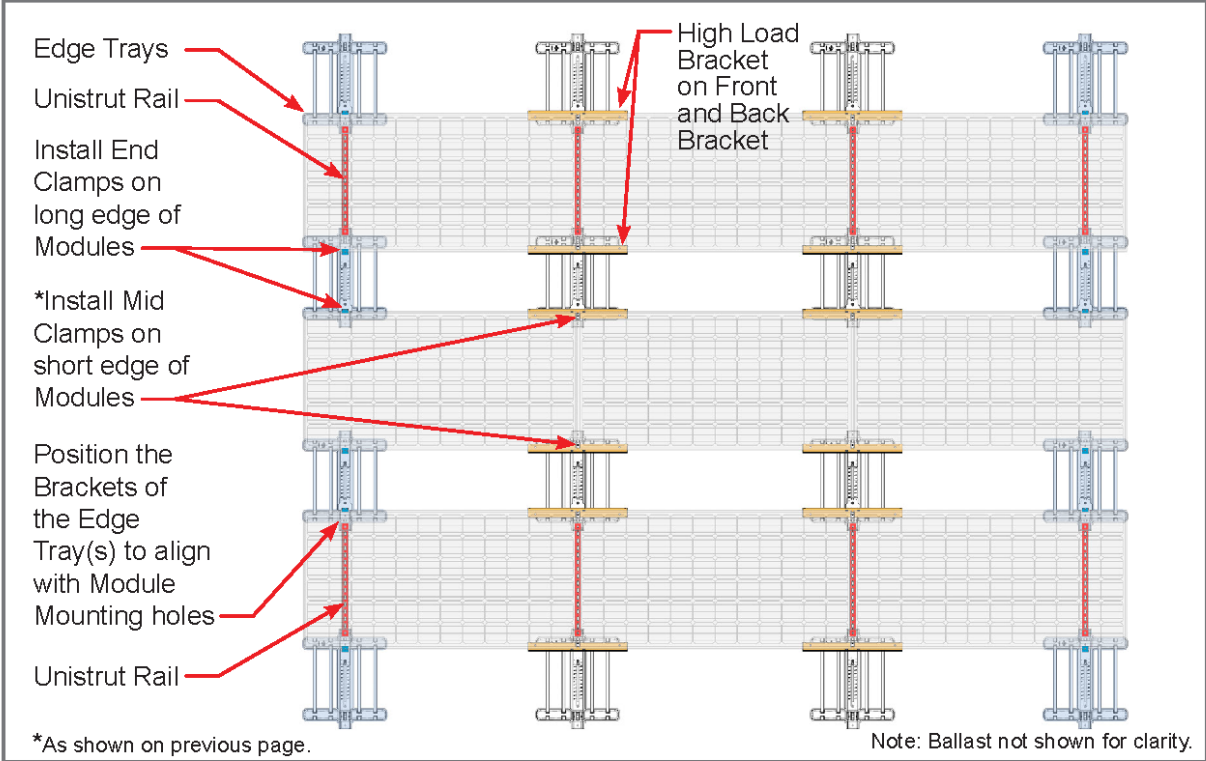

Install Unistrut Rail sections on north and south rows, joining the first two Edge Trays of each row together.

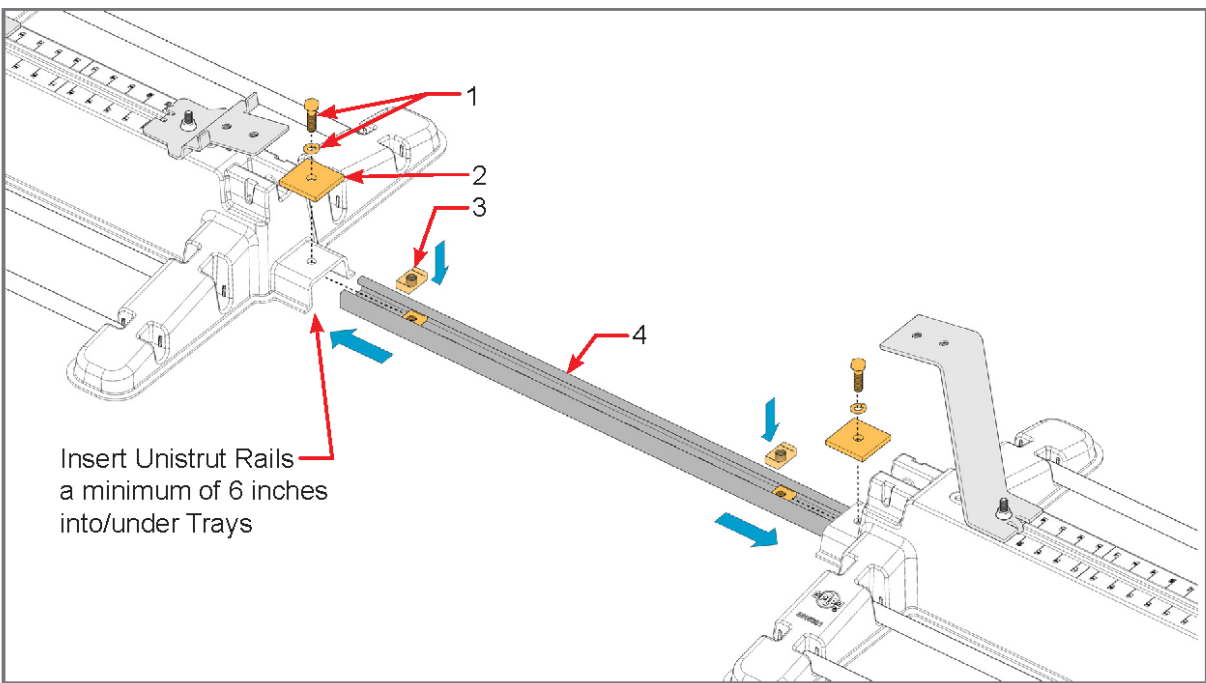

Item	Description	Qty	Supplied By
1	3/8" x 1-1/4" Hex Bolt & Lockwasher - Stainless Steel	4	Customer
2	Channel Nut, Unistrut p/n P3008 or Equivalent	2	Customer
3	Square Washer, Unistrut p/n P1063 or Equivalent	2	Customer
4	Rail, Unistrut p/n P3300 or Equivalent	N/A	Customer

Installing Unistrut Rails - Tilted (5° & 10°) Array (cont.)

Align Edge Trays with the Module mounting holes, and install the Module End Clamps on the long edge of the Module.

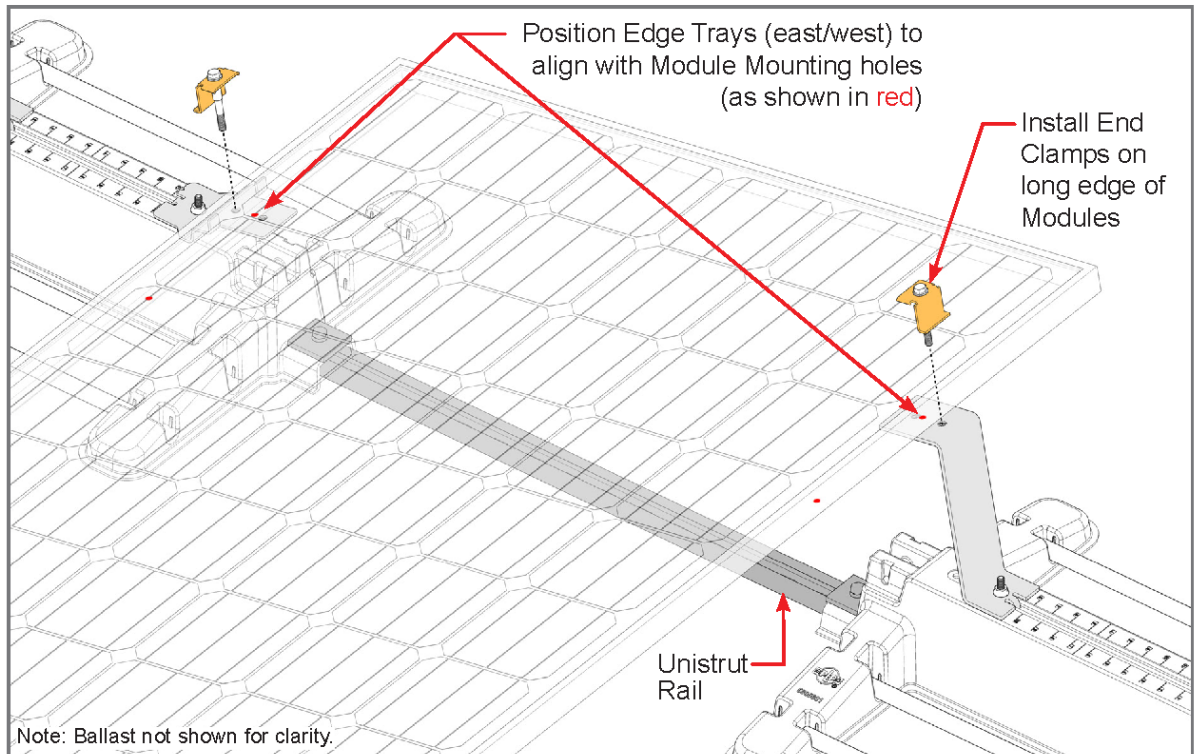

Installing Seismic Attachments - All Systems

CAUTION

Without exception, Seismic Attachments must be installed/applied per the job specific project drawings. Be absolutely certain that the roof anchors are installed/secured to the roof surface per the manufacturer's specifications. Failure to do so could lead to a catastrophic structural failure and severe personal injury or death. Furthermore, failure to meet specifications voids the system warranty.

NOTE

These instructions do not include the installation of the attachment to the roof top surface. Refer to the attachment manufacturer for product specific installation instructions.

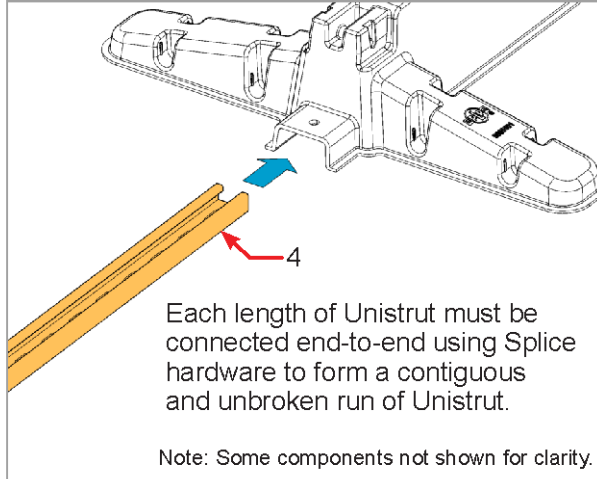

Rail Splice

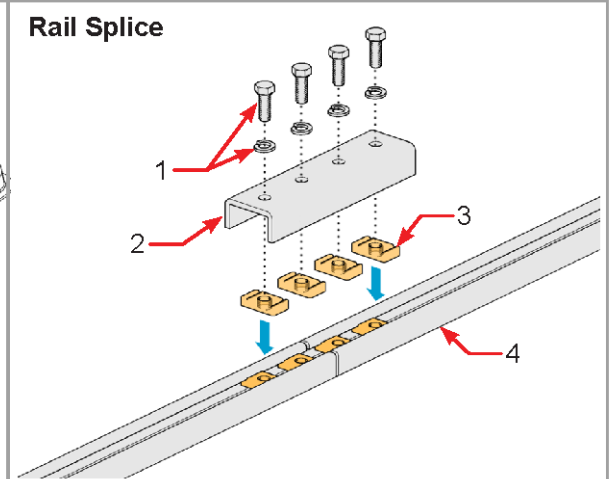

Pass the Unistrut under the Ballast Trays and position N-S to accommodate roof attachment locations.

As needed, Splice Unistrut sections together. **Torque to 20 ft.-lbs.**

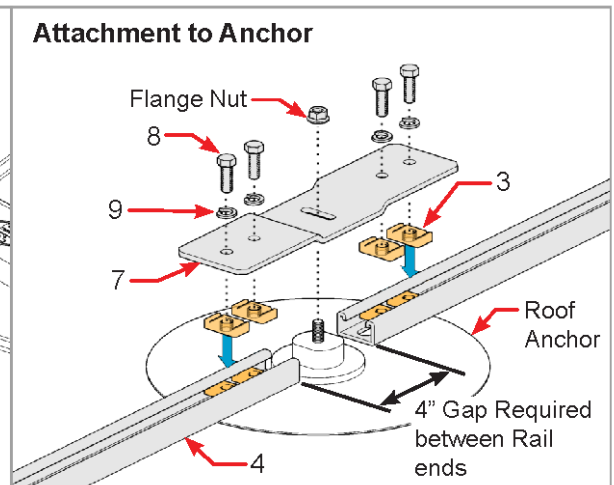
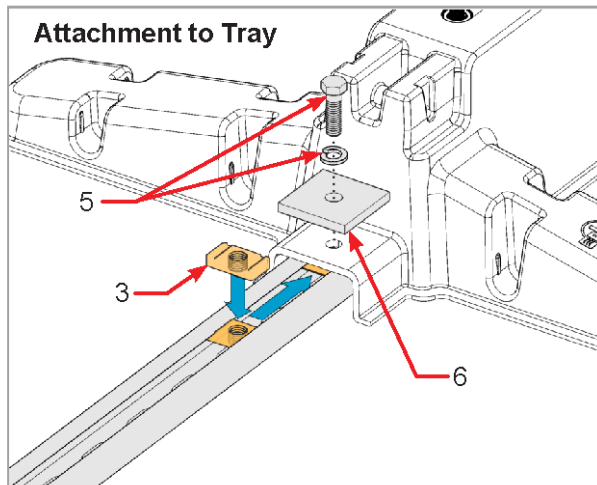

Secure the Unistrut to the Ballast Trays (it's only necessary to secure the north end of each Ballast Tray) **Torque to 20 ft.-lbs.**

Install/secure the Roof Anchor to the rooftop. Secure the Unistrut to the Roof Anchor with the Seismic Attachment and hardware. **Torque to 20 ft.-lbs.**

Item	Description	Qty	Supplied By
1	3/8-1" Hex Bolt & Lockwasher - Stainless Steel	4	Customer
2	Splice, Unistrut p/n P4377 or Equivalent	N/A	Customer
3	Channel Nut, Unistrut p/n P3008 or Equivalent	4	Customer
4	Rail, Unistrut p/n P3300 or Equivalent	N/A	Customer
5	3/8 x 1-1/4" Hex Bolt & Lockwasher - Stainless Steel	N/A	Customer
6	Square Washer, Unistrut p/n P1063 or Equivalent	N/A	Customer
7	Attachment Plate (Anchor Attachment Kit)	1	PLP
8	3/8-16 x 1" Hex Bolt (Anchor Attachment Kit)	4	PLP
9	3/8 Lock Washer (Anchor Attachment Kit)	4	PLP



PREFORMED LINE PRODUCTS

Global Headquarters
660 Beta Drive
Mayfield Village, OH 44143

Telephone: 440.461.5200
Fax: 440.442.8816
preformed.com
info@plpsolar.com

© 2020 Preformed Line Products
SP3470-1