

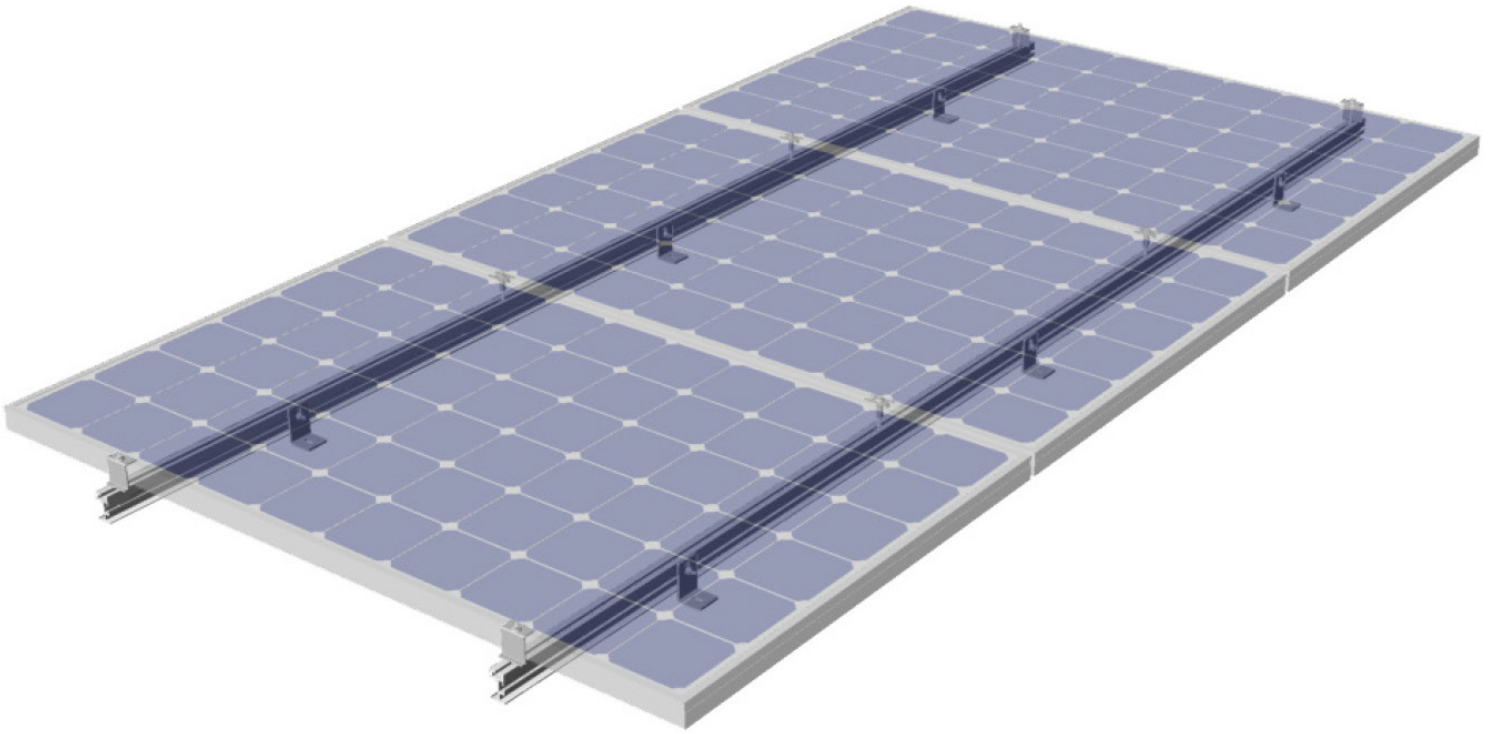

**PP** PREFORMED LINE PRODUCTS

---



## **POWER RAIL™ P8**

Assembly Instructions

**step-by-step  
assembly and installation**

## **SAFETY CONSIDERATIONS**

This application procedure is not intended to supersede any company construction or safety standards. This procedure is offered only to illustrate safe application for the individual.

**FAILURE TO FOLLOW THESE PROCEDURES MAY RESULT IN PERSONAL INJURY OR DEATH.**

**Do not modify this product under any circumstances, except where noted in this application procedure.**

This product is intended for use by trained technicians only.

**This product should not be used by anyone who is not familiar with, and not trained to use it.**

When working in the area of energized lines, extra care should be taken to prevent accidental electrical contact. Be sure to wear proper safety equipment per your company protocol.

For proper performance and personal safety, be sure to select the proper size PREFORMED™ product before application.

PREFORMED products are precision devices. To ensure proper performance, they should be stored in cartons under cover and handled carefully.

The POWER RAIL P8 conforms to ANSI/UL UL2703 (2015) Standard for Safety First Edition: Mounting Systems, Mounting Devices, Clamping/Retention Devices, and Ground Lugs for Use with Flat-Plate Photovoltaic Modules and Panels.

**Electrical**

Note: Electrical installations must be in accordance with the National Electric Code ANSI / NFPA 70. Contact your local Authorities Having Jurisdiction (AHJ) for additional details.

Max Overcurrent Protective Device (OCPD) Rating: 25A  
Equipment Grounding Conductor Sizing

Module Fuse Rating	Copper Wire Size
<15 AMPS	#14 AWG 90° C
<20 AMPS	#12 AWG 90° C
20 - 60 AMPS	#10 AWG 90• C

**Splice Plates**

Splice Plates have been tested per UL2703 Bonding & Grounding requirements without the use of Bonding Jumpers. See assembly procedures for proper assembly.

**Module Clamps**

Module clamps have integrated grounding and have been tested to UL 2703. See Module Compatibility List for list of approved modules. Module Orientation: Portrait or Landscape

**Fire Class Resistance Rating**

The system fire class rating is only valid when the installation is conducted strictly in accordance with this manual.

The assembly is to be mounted over a fire resistant roof covering rated for the application.

Meets the requirements of Class A Steep Slope Flush-Mounting Applications when using Type 1, Listed Photovoltaic Modules.

Testing conducted with a 5" Gap (distance between roof covering and PV module frame) per UL1703 allows the system to be installed with any gap per manufacturer's instructions.

Steep Slope refers to roofs with slopes greater than or equal to 2:12.

**Structural Certification**

Mechanical Load Rating: Exceeds the minimum design load rating of UL2703 section 21.4 (30 psf downward, 30 psf upward, and 13.67 psf downslope) load. Actual system capacity defined by span/cantilever carts and/or configuration tools with PE review.

**Marking**

Product markings identified per UL2703 are to be located in a location that is readily accessible for inspection.

**Periodic Inspection**

Periodic re-inspection is a recommended system maintenance procedure to check for loose components or corrosion. If any loose components and/or corrosion is found, the affected components are required to be replaced immediately, with the original mounting system manufacturer's component parts.

### About the product

The POWER RAIL top-clamping PV module mounting system is engineered to reduce installation costs and provide maximum strength for parallel-to-roof or tilt up mounting applications.

Designed with the professional PV solar installer in mind, the top-clamping rails utilize a single tool with a revolutionary RAD™ Fastener for faster bolt placement. The unique shape of the RAD provides an anti-rotation feature, locking the bolt in the proper orientation when installed. The high strength rigid rails also include an integral wiring channel for securing cables and providing a professional finish. The POWER RAIL Mounting System features the industry's broadest selection of mounting supports, designed for secure and water tight attachments to any roof style.

For recommendations on a specific installation, please:

Visit [www.preformed.com](http://www.preformed.com) and select the POWER RAIL Configuration Design Tool.

Contact us by Phone: 800-260-3792

Send an Email request: [info@plpsolar.com](mailto:info@plpsolar.com)

### About these instructions:

- The instructions do not include any information on the selection or installation of attaching hardware to be mounted to the roof substrate. For information on compatible attaching hardware, see our publication titled "POWER RAIL Design Guidelines".
- Begin after all roof mounted attaching hardware has been installed and secured to the roof substrate.

- They show the POWER RAIL Mounting System being installed on the "Power Rail PV Flash" roof attachment system.
- These instructions are intended to be used by individuals with sufficient technical skills for the task. Knowledge and use of hand tools, measuring devices and torque values is also required.
- Included, are various Notes, Cautions, and Warnings that are intended to assist in the assembly process and/or to draw attention to the fact that certain assembly steps may be dangerous and could cause serious physical injury and/or damage to components. Follow the procedures and precautions in these instructions carefully.

### Required Tools

- 1/2 inch wrench or socket for 5/16 inch module clamp hardware
- Torque wrench
- Ratchet wrench
- Ratchet extension bar
- Tape Measure
- Square



**POWER RAIL™ P8 Main Components**

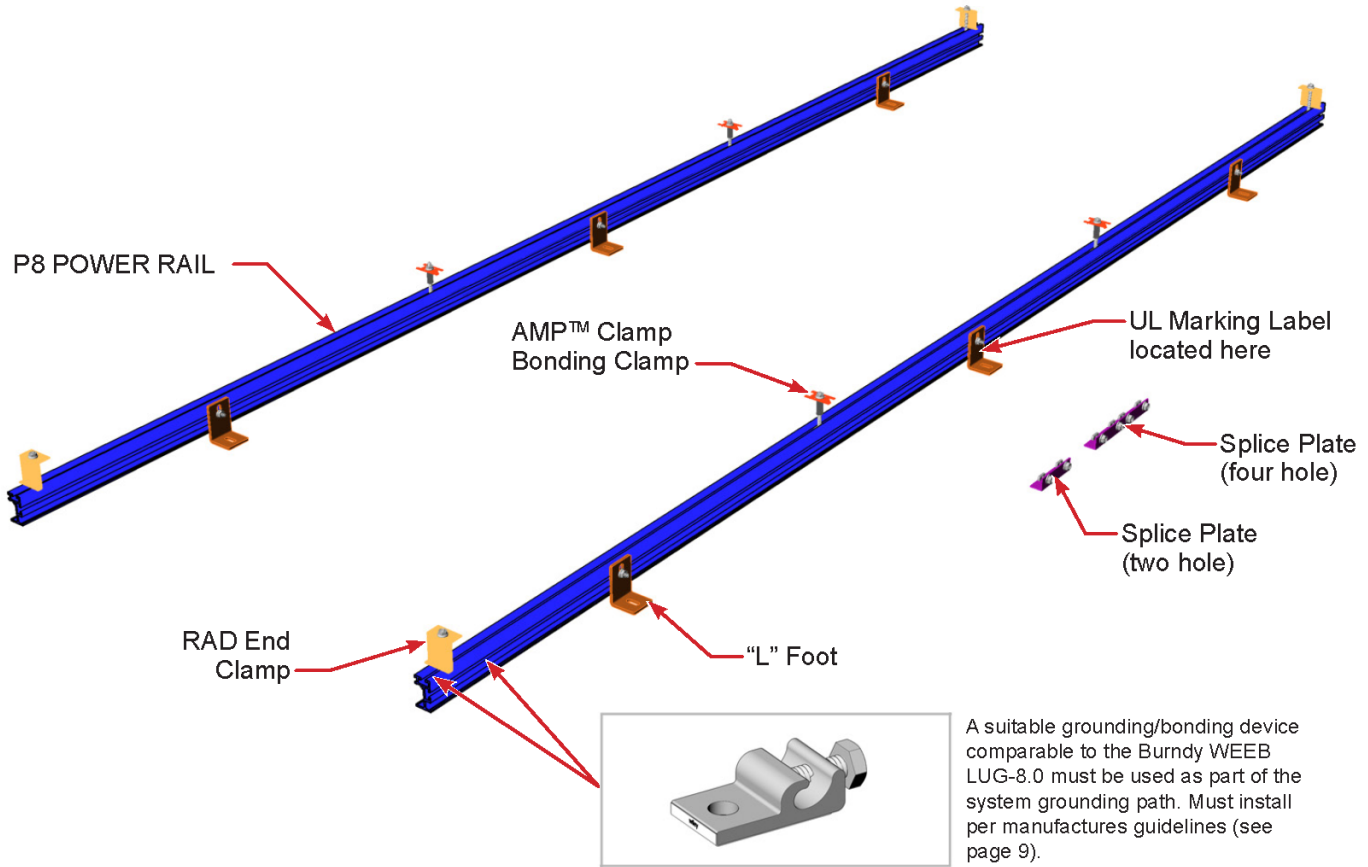

**There are five main components and attaching hardware.**

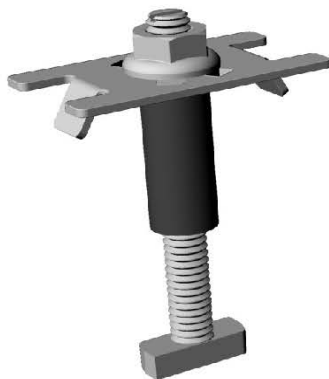

Factory Assembled  
AMP Clamp  
Bonding Clamp

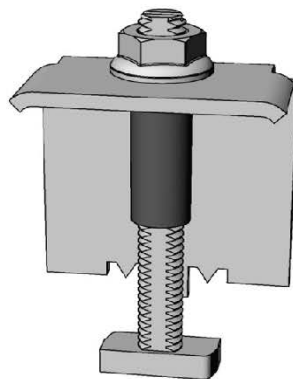

Factory Assembled  
(patented)  
RAD Grounded End Clamp

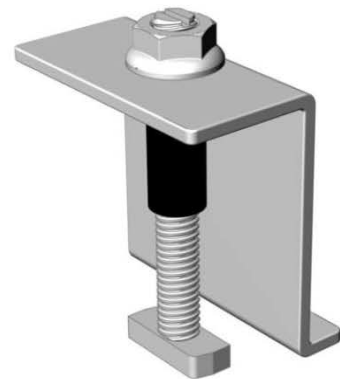

Factory Assembled  
(patented)  
RAD™ End Clamp

**POWER RAIL™ P8 Parts Identification**

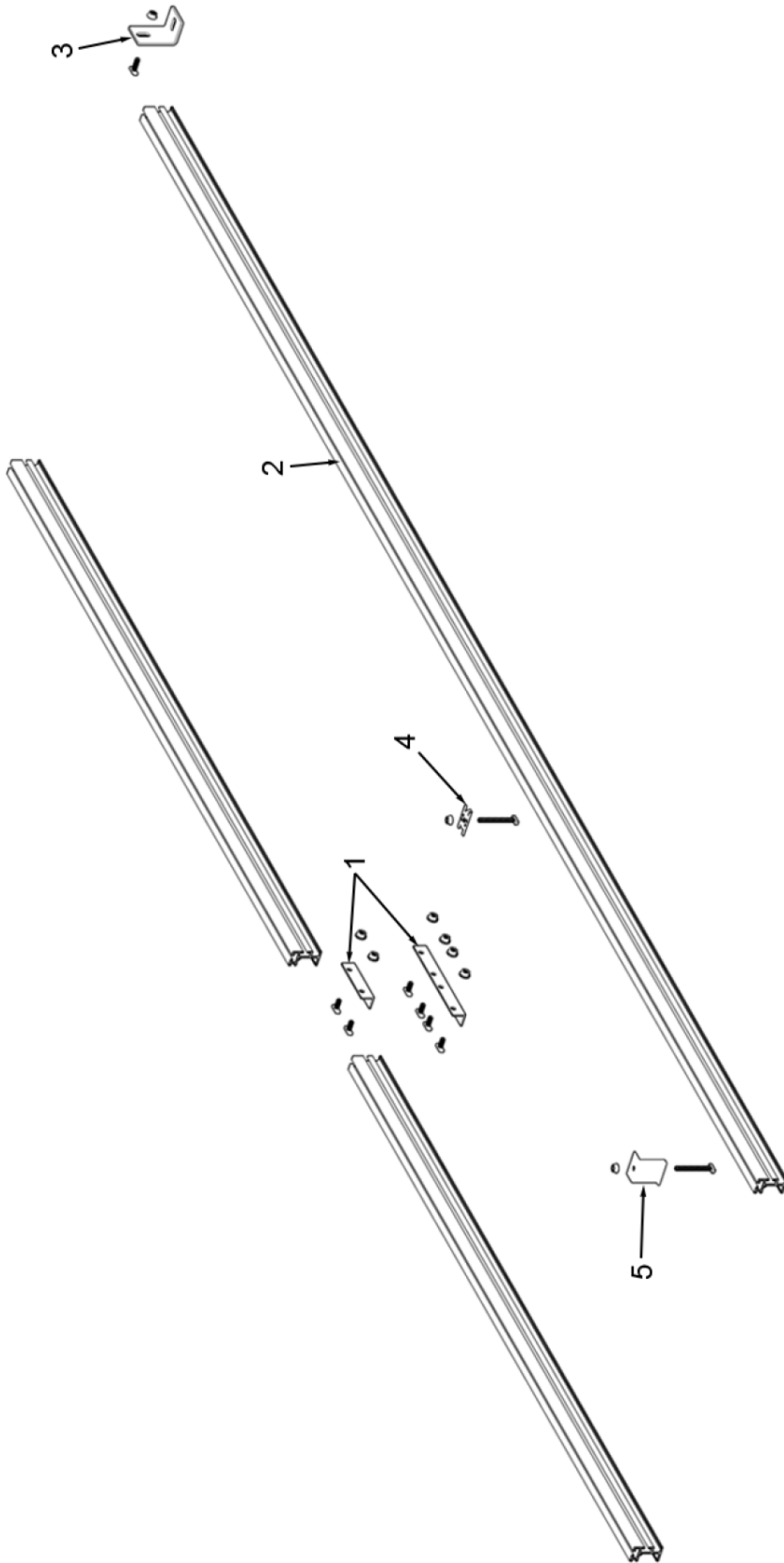

Item	Description	Qty
1	Splice Plate, two or four hole, (5/16" x 3/4") turn bolts, flange nuts	1 per Rail Joint
2	Power Rail P8	2 per Rail Set
3	"L" Foot, (5/16" x 3/4") turn bolt, flange nut	Refer to Power Rail Design Guidelines
4	AMP Clamp, (5/16" x *) RAD bolt, flange nut	2 per 3/8" gap between modules
5	RAD End Clamp, (5/16" x *) RAD bolt, flange nut	4 per Rail Set
* 2", 2-1/4", 2-1/2", or 2-3/4" bolt. Length is dependent on depth of PV Module frame		
Notes:		
1. Install Mid Clamp with AMP Clamp RAD bonding Mid Clamp.		
2. Option to install Universal End Clamp, End Clamp with carriage bolt or RAD End Clamp.		



**1 Install the "L" Feet**

**NOTE**

L feet can be attached directly to the roof substrate with the proper hardware. See POWER RAIL Design Guidelines for more information. Information on appropriate anchoring hardware is available on an individual product basis.

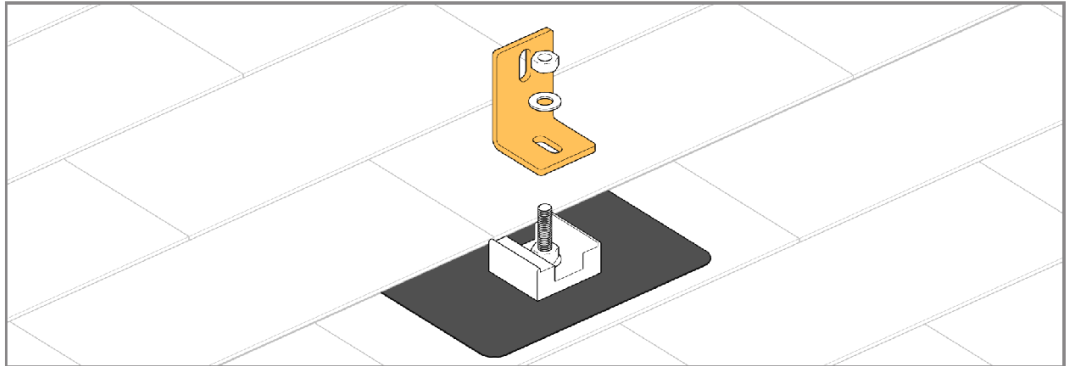

Secure "L" foot to appropriate anchoring device per the manufacturers instructions. Above is shown using the POWER RAIL PV Flash and attaching hardware.

Position "L" foot on compression block and secure with 5/16" Hex Nut and Flat Washer. **Torque to 15 ft.-lbs.**

**2 Attach POWER RAIL™ to "L" Feet**

**CAUTION**

Cantilever and span dimensions are a design specification. Consult the design manual to match these dimensions to site conditions. It's important to use the unique cantilever and span dimension specific to the install. Failure to do so could lead to excessive deflection and/or premature system failure.

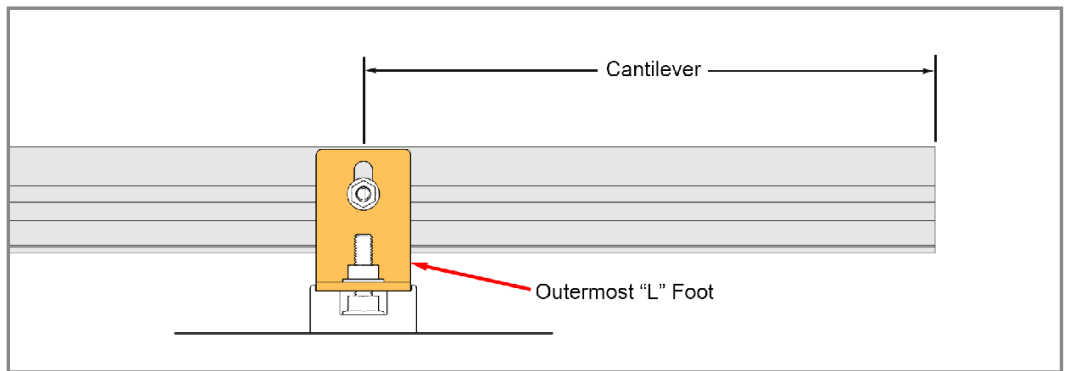

Secure "L" foot to appropriate anchoring device per the manufacturers instructions. Above is shown using the POWER RAIL PV Flash and attaching hardware.

Position "L" foot on compression block and secure with 5/16" Hex Nut and Flat Washer. **Torque to 15 ft.-lbs.**

**NOTE**

Turn bolts must be locked into the channel by rotating clockwise 90-degrees. Use the indicator slot on the threaded end to identify whether or not the bolt has been locked.

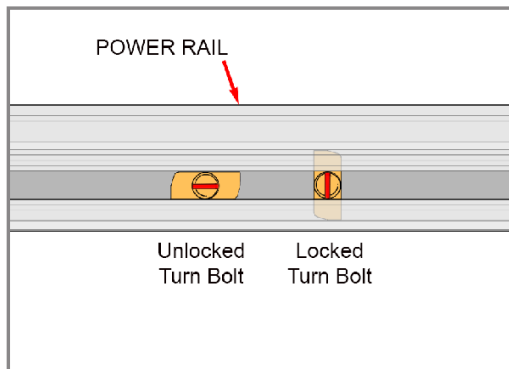

Secure "L" foot to appropriate anchoring device per the manufacturers instructions. Above is shown using the POWER RAIL PV Flash and attaching hardware.

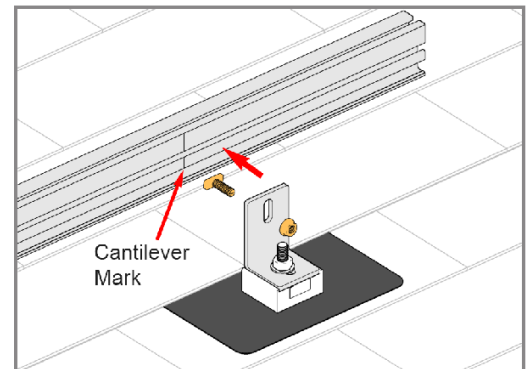

Position "L" foot on compression block and secure with 5/16" Hex Nut and Flat Washer. **Torque to 15 ft.-lbs.**

**3 Splicing POWER RAIL™ with Splice Plates**

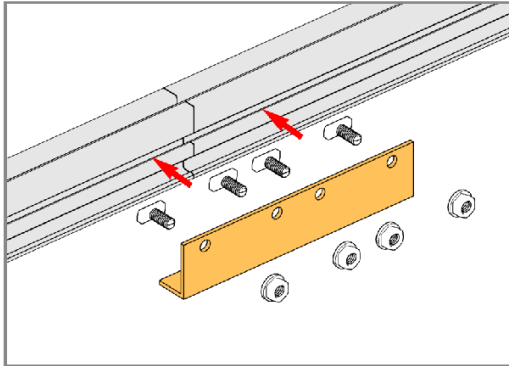

Splice Plates come in two configurations, 2-hole or 4-hole (above is a 4-hole). Insert 5/16" x 3/4" Turn Bolts into Power Rail and rotate 90-degrees to lock

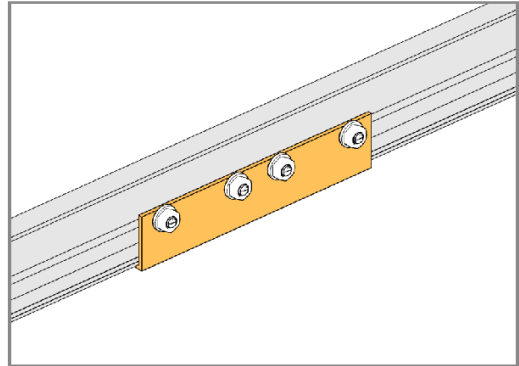

Turn Bolts in place. Align Splice Plate with center of splice and secure to POWER RAIL with 5/16" Flange Nuts. **Torque to 15 ft.-lbs.**

**4 Install the Modules**

**CAUTION**  
 This is a two person activity. In addition to the difficulties associated with working on a sloped rooftop, PV Modules are heavy. One person should hold and align the modules while a second person secures modules with clamping hardware. Failure to do so could lead to serious personal injury and/or damaged components.

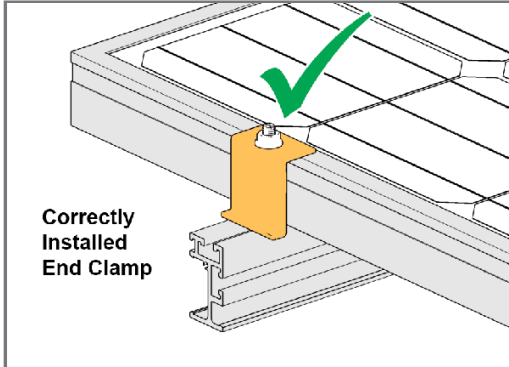

**Correctly Installed End Clamp**

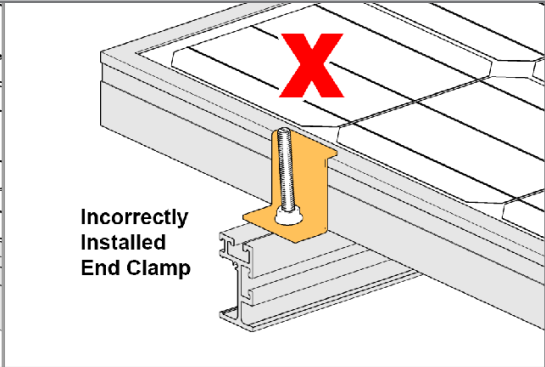

**Incorrectly Installed End Clamp**

End Clamps must be installed as shown above left, not upside down as shown to the right.

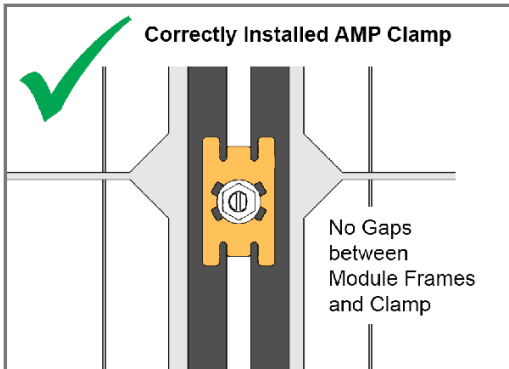

**Correctly Installed AMP Clamp**

No Gaps between Module Frames and Clamp

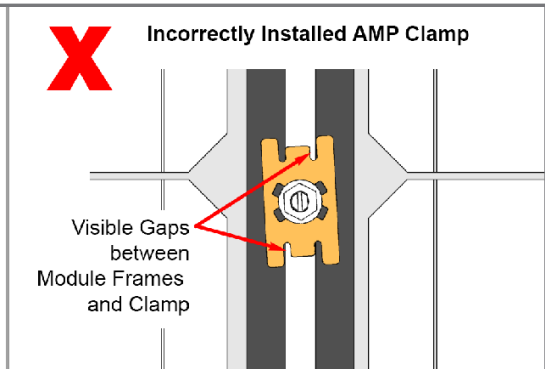

**Incorrectly Installed AMP Clamp**

Visible Gaps between Module Frames and Clamp

AMP Clamp bonding Mid Clamps must be installed as shown at above left and not as shown to the right. There cannot be any visible gaps between the bonding Mid Clamps and module frames.

## 1 4 Install the Modules (cont.)

### NOTE

The RAD bolts used in the AMP-Clamps and End Clamps must be locked into the channel by rotating clockwise 90-degrees. Use the indicator slot on the threaded end to identify whether or not the bolt has been locked.

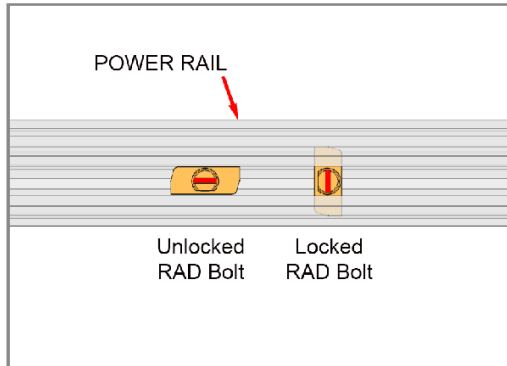

AMP Clamp bonding Mid Clamps are inserted into the Power Rail and positioned between adjacent Modules. Insert the 5/16" RAD Bolt into POWER RAIL™ and

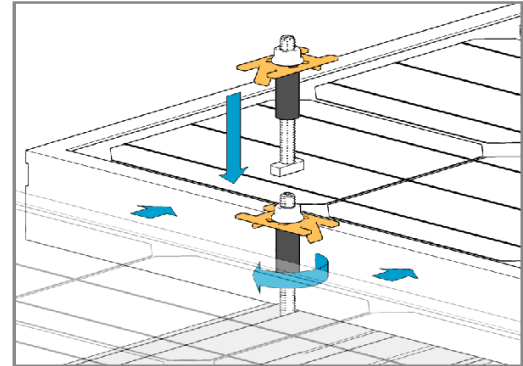

rotate 90-degrees clockwise to lock the RAD Bolt within the POWER RAIL. Push Modules against AMP Clamp. Tighten 5/16" Flange Nut. **Torque to 15 ft.-lbs.**

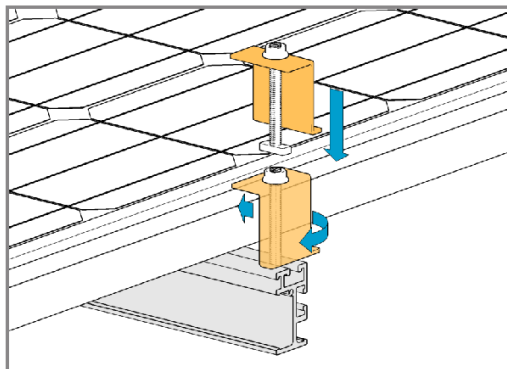

RAD End Clamps are used on the outer Modules. Insert the 5/16" RAD Bolt into POWER RAIL and rotate 90-degrees clockwise to lock the RAD Bolt within the POWER RAIL. Secure with 5/16" Flange Nut. **Torque to 15 ft.-lbs.**

**Grounding/Bonding Path Non-Anodized Rails**

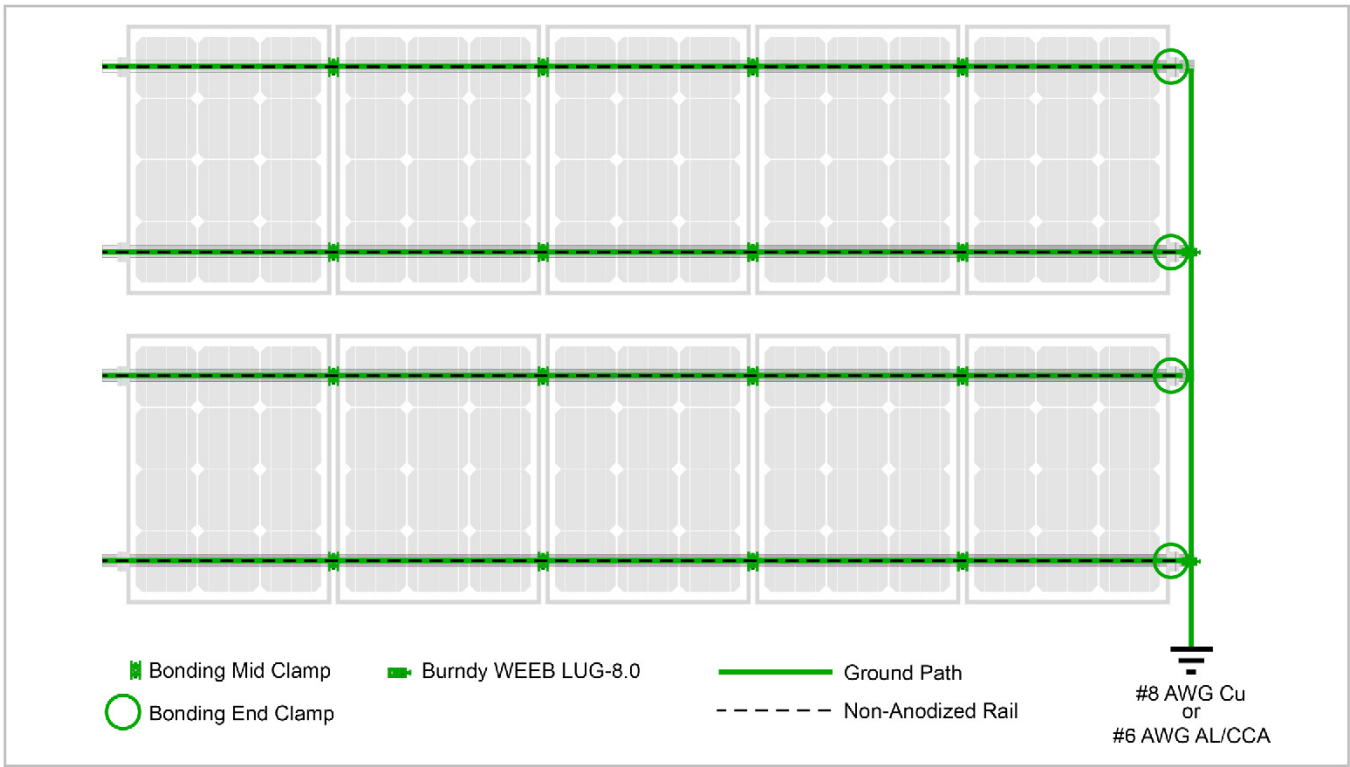

**Grounding/Bonding Path Anodized Rails**

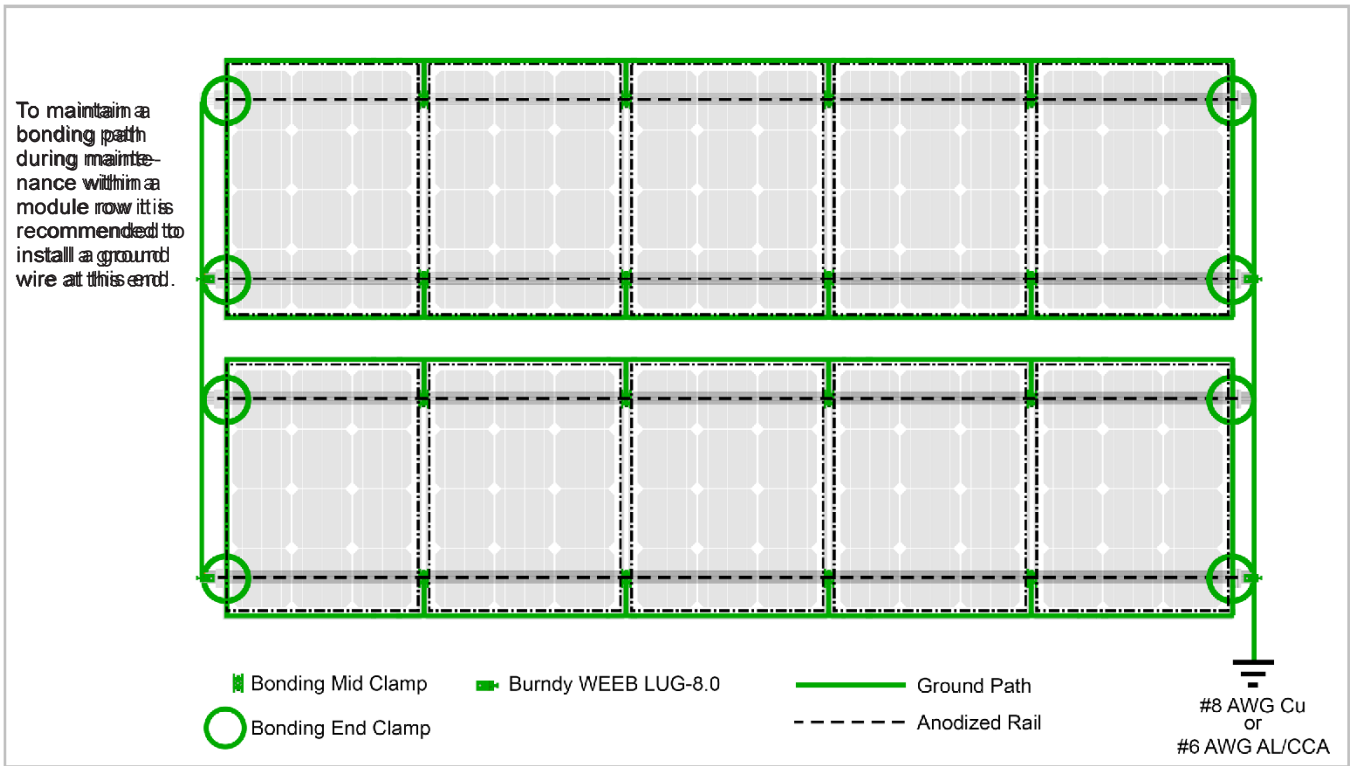

## Installing a WEEB-LUG 8.0

### IMPORTANT

Before installing verify with the lug manufacturer for any updates or revisions to these lug installation instructions.

One of two mounting methods may be used defined here as Methods A and B. Lug is suitable for use with 14-6AWG solid or stranded copper conductor when tightened to 5ft-lbs.

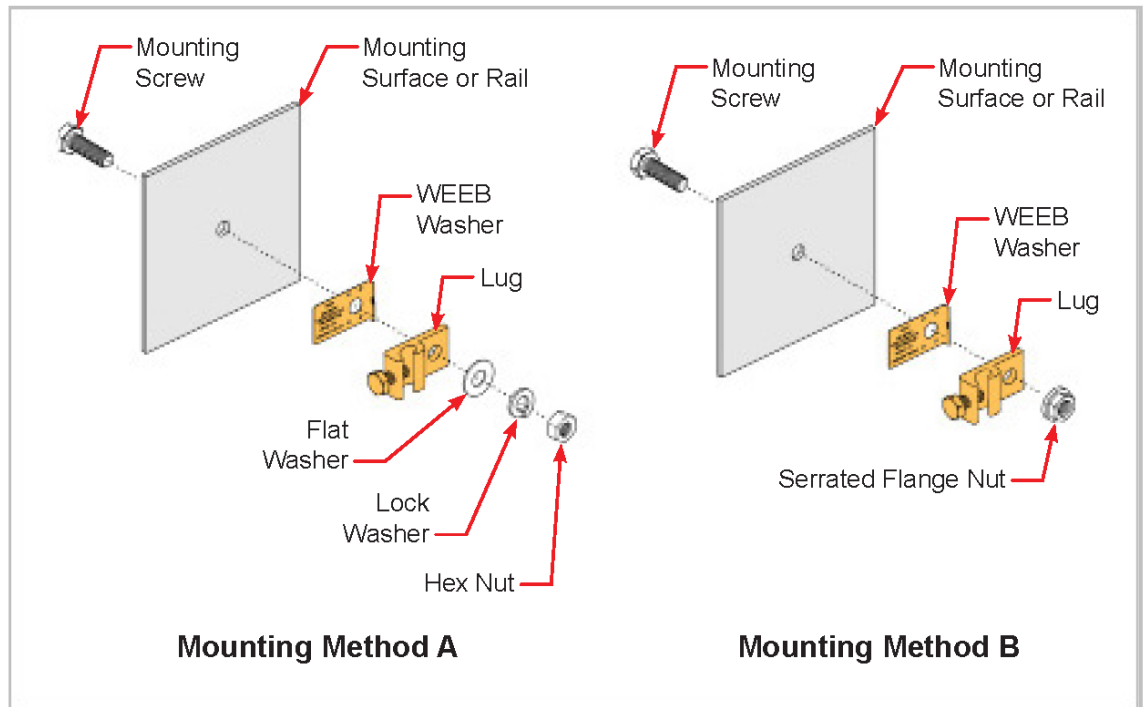

### IMPORTANT NOTES

1. Before installing verify with the lug manufacturer for any updates or revisions to these lug installation instructions. The instructions on this page only address the WEEB-LUG-8.0 as found within the manufacturers (Burdny) document number 50016572 Rev E.
2. The NEC section 690.43 states, "Exposed non-current carrying metal parts of module frames, equipment, and conductor enclosures shall be grounded in accordance with 250.134 or 250.136 (A) regardless of voltage."
3. For Proper Equipment Grounding Conductor (EGC) and Overcurrent Protection Device (OCPD) sizing, refer to NEC sections 250.66, 250.122 and 250.166.



## **PREFORMED** LINE PRODUCTS

---

Global Headquarters  
660 Beta Drive  
Mayfield Village, OH 44143

Telephone: 800.260.3792  
Fax: 440.442.8816  
preformed.com  
Email: info@plpsolar.com

---

© 2020 Preformed Line Products  
SP3412-3