

POWER RAIL™ P6

ASSEMBLY INSTRUCTIONS

**step-by-step
assembly and installation**

SAFETY CONSIDERATIONS

This application procedure is not intended to supersede any company construction or safety standards. This procedure is offered only to illustrate safe application for the individual. **FAILURE TO FOLLOW THESE PROCEDURES MAY RESULT IN PERSONAL INJURY OR DEATH.**

Do not modify this product under any circumstances, except where noted in this application procedure.

This product is intended for use by trained technicians only. **This product should not be used by anyone who is not familiar with, and not trained to use it.**

When working in the area of energized lines, extra care should be taken to prevent accidental electrical contact. Be sure to wear proper safety equipment per your company protocol.

For proper performance and personal safety, be sure to select the proper size PREFORMED™ product before application.

PREFORMED products are precision devices. To ensure proper performance, they should be stored in cartons under cover and handled carefully.

POWER RAIL™ P6 Ratings

The POWER RAIL P6 conforms to ANSI/UL UL2703 (2015) Standard for Safety First Edition: Mounting Systems, Mounting Devices, Clamping/Retention Devices, and Ground Lugs for Use with Flat-Plate Photovoltaic Modules and Panels.

Electrical

Note: Electrical installations must be in accordance with the National Electric Code ANSI / NFPA 70. Contact your local Authorities Having Jurisdiction (AHJ) for additional details.

Max Overcurrent Protective Device (OCPD) Rating: 25A

Equipment Grounding Conductor Sizing

Module Fuse Rating	Copper Wire Size
<15 AMPS	#14 AWG 90°C
<20 AMPS	#12 AWG 90°C
20-60 AMPS	#10 AWG 90°C

Splice Plates

Splice Plates have been tested per UL2703 Bonding & Grounding requirements without the use of Bonding Jumpers.

See assembly procedures for proper assembly.

Module Clamps

Module clamps have integrated grounding and have been tested to UL2703.

See Module Compatibility List for list of approved modules.

Module Orientation: Portrait or Landscape

Fire Class Resistance Rating

The system fire class rating is only valid when the installation is conducted strictly in accordance with this manual.

Meets the requirements of Class A Steep Slope Flush-Mounting Applications when using Type 1, Listed Photovoltaic Modules.

Testing conducted with a 5" Gap (distance between roof covering and PV module frame) per UL1703 allows the system to be installed with any gap per manufacturer's instructions.

Steep Slope refers to roofs with slopes greater than or equal to 2:12.

Structural Certification

Mechanical Load Rating: Exceeds the minimum design load rating of UL2703 section 21.4 (30 psf downward, 30 psf upward, and 13.67 psf downslope) load. Actual system capacity defined by span/cantilever carts and/or configuration tools with PE review.

Marking

Product markings identified per UL2703 are to be located in a location that is readily accessible for inspection.

Periodic Inspection

Periodic re-inspection is a recommended system maintenance procedure to check for loose components or corrosion. If any loose components and/or corrosion is found, the affected components are required to be replaced immediately with the original mounting system manufacturer's component parts.

POWER RAIL™ P6

About the product

The POWER RAIL top-clamping PV module mounting system is engineered to reduce installation costs and provide maximum strength for parallel-to-roof or tilt up mounting applications.

Designed with the professional PV solar installer in mind, the top-clamping rails utilize a single tool with a revolutionary RAD™ Fastener for faster bolt placement. The unique shape of the RAD provides an anti-rotation feature, locking the bolt in the proper orientation when installed. The high strength rigid rails also include an integral wiring channel for securing cables and providing a professional finish. The POWER RAIL Mounting System features the industry's broadest selection of mounting supports, designed for secure and water tight attachments to any roof style.

For recommendations on a specific installation, please:

Visit preformed.com and select the POWER RAIL Configuration Design Tool.

Contact us by Phone: 800-260-3792

Send an Email request: info@plpsolar.com

About these instructions:

- The instructions do not include any information on the selection or installation of attaching hardware to be mounted to the roof substrate. For information on compatible attaching hardware, see our publication titled "POWER RAIL Design Guidelines".
- Begin after all roof mounted attaching hardware has been installed and secured to the roof substrate.

- They show the POWER RAIL Mounting System being installed on the "POWER RAIL PV Flash" roof attachment system.
- These instructions are intended to be used by individuals with sufficient technical skills for the task. Knowledge and use of hand tools, measuring devices and torque values is also required.
- Included, are various Notes, Cautions, and Warnings that are intended to assist in the assembly process and/or to draw attention to the fact that certain assembly steps may be dangerous and could cause serious physical injury and/or damage to components. Follow the procedures and precautions in these instructions carefully.

Required Tools

- 1/2 inch wrench or socket for 5/16 inch module clamp hardware
- Torque wrench
- Ratchet wrench
- Ratchet extension bar
- Tape Measure
- Square

POWER RAIL P6 Main Components

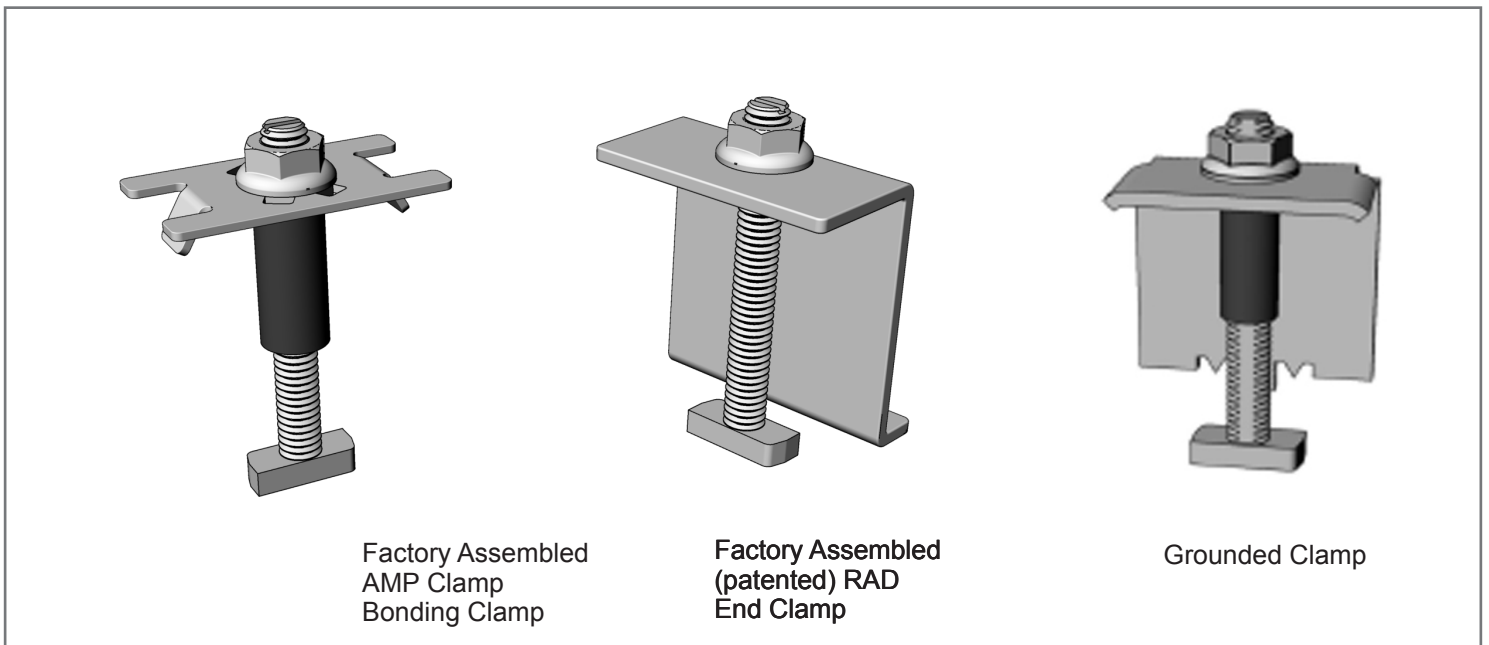
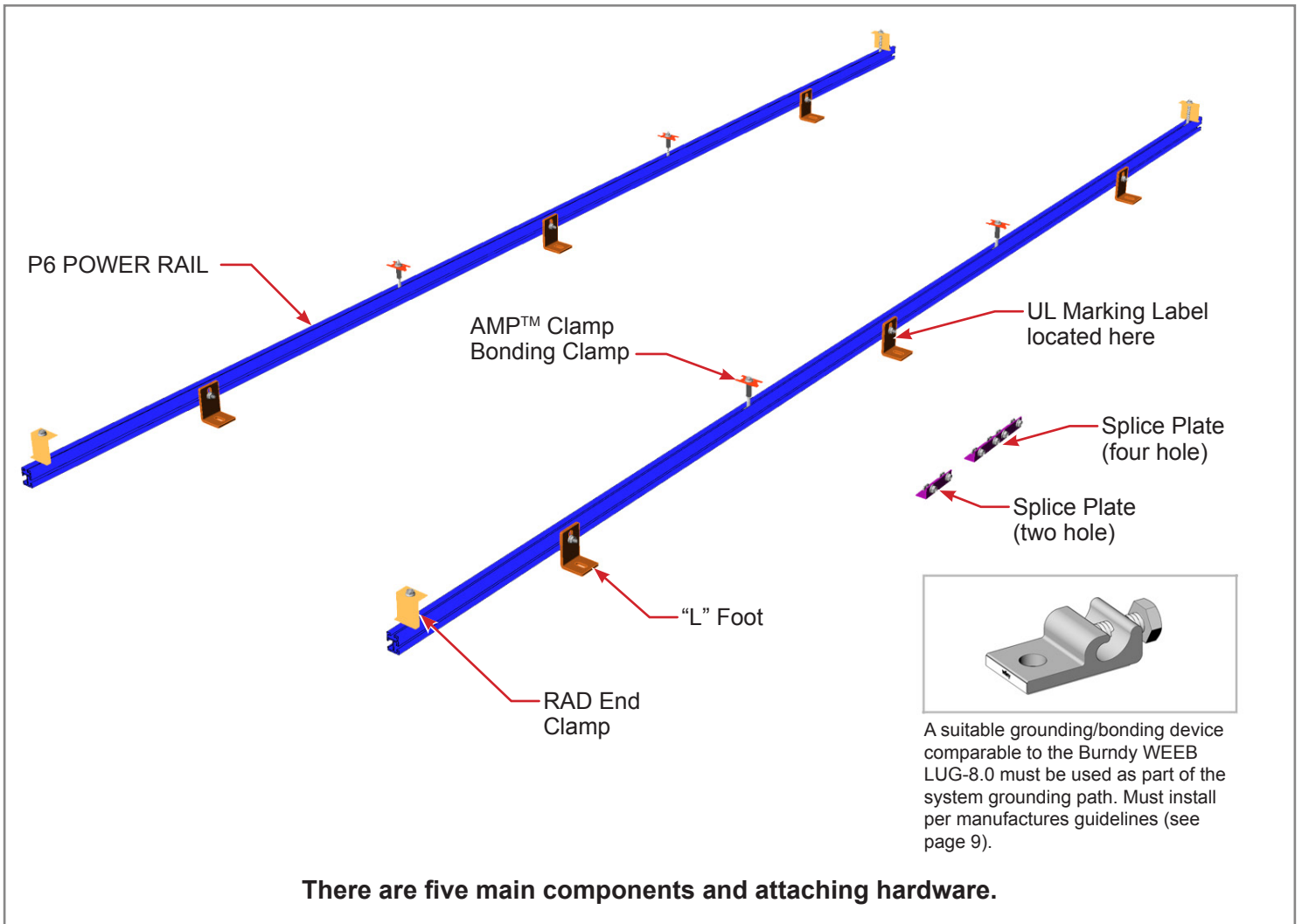

POWER RAIL P6 Parts Identification

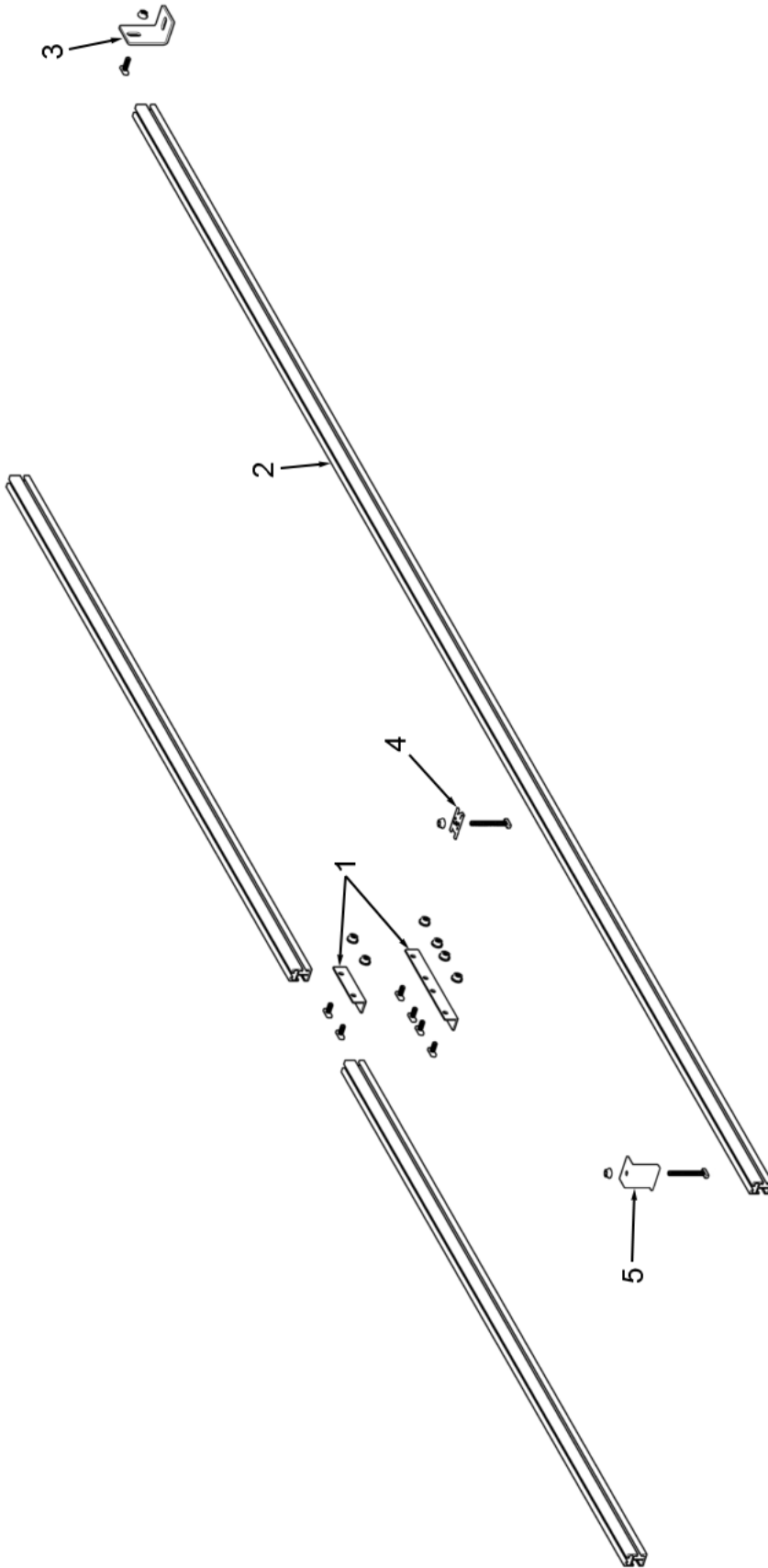

Item	Description	Qty
1	Splice Plate, two or four hole, (5/16" x 3/4") turn bolts, flange nuts	1 per Rail Joint
2	POWER RAIL P6	2 per Rail Set
3	"L" Foot, (5/16" x 3/4") turn bolt, flange nut	Refer to POWER RAIL Design Guidelines
4	AMP Clamp, (5/16" x *) RAD bolt, flange nut	2 per 3/8" gap between modules
5	RAD End Clamp, (5/16" x *) RAD bolt, flange nut	4 per Rail Set
* 2", 2-1/4", 2-1/2", or 2-3/4" bolt. Length is dependent on depth of PV Module frame		
Notes:		
1. Install Mid Clamp with AMP Clamp RAD bonding Mid Clamp.		
2. Option to install Universal End Clamp, End Clamp with carriage bolt or RAD End Clamp.		

1 Install the "L" Feet

NOTE

L feet can be attached directly to the roof substrate with the proper hardware. See POWER RAIL Design Guidelines for more information.

Information on appropriate anchoring hardware is available on an individual product basis.

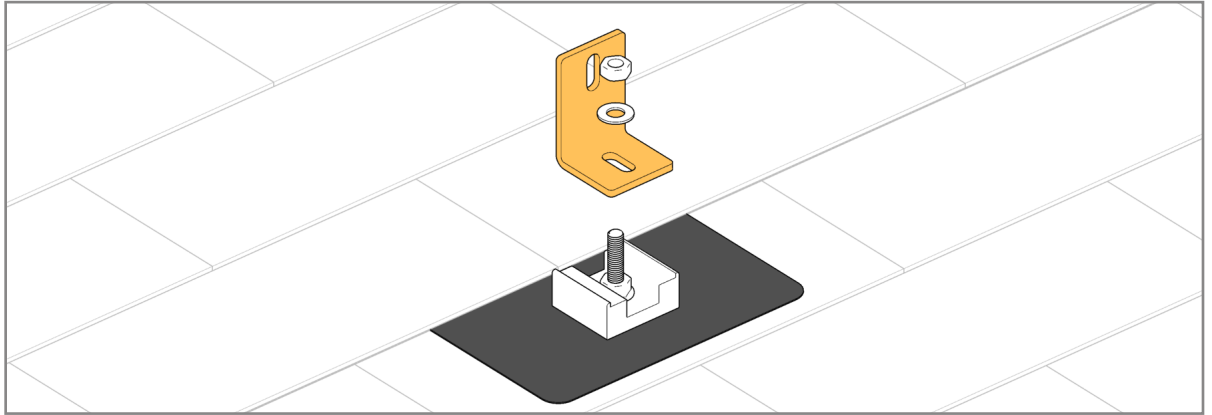

Secure "L" foot to appropriate anchoring device per the manufacturers instructions. Above is shown using the POWER RAIL PV Flash and attaching hardware.

Position "L" foot on compression block and secure with 5/16" Hex Nut and Flat Washer. **Torque to 15 ft.-lbs.**

2 Attach POWER RAIL to "L" Feet

CAUTION

Cantilever and span dimensions are a design specification. Consult the design manual to match these dimensions to site conditions. It's important to use the unique cantilever and span dimension specific to the install. Failure to do so could lead to excessive deflection and/or premature system failure.

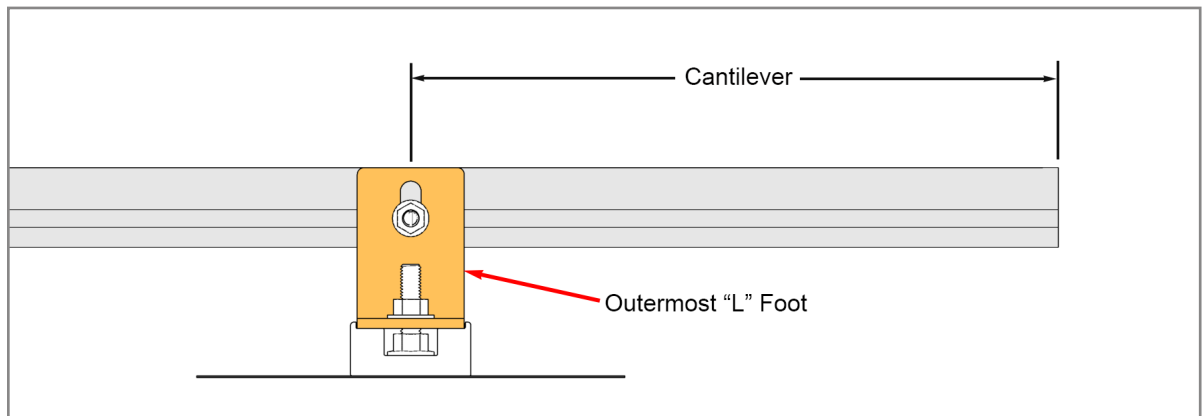

The POWER RAIL overhangs beyond the outermost "L" Foot. This overhang is referred to as "cantilever", or abbreviated as "C'ver". The distance between adjacent "L" Feet is referred to as "span". The length of both the cantilever and the span are dependent on

several factors, unique to each installation and are determined by the system design.

Measure and mark the cantilever dimension supplied by the design manual onto the POWER RAIL.

NOTE

Turn bolts must be locked into the channel by rotating clockwise 90-degrees. Use the indicator slot on the threaded end to identify whether or not the bolt has been locked.

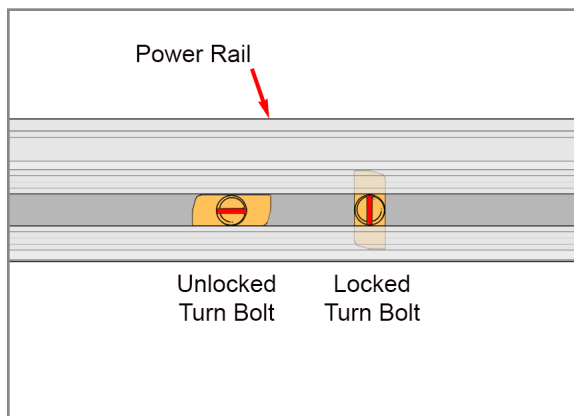

Insert 5/16" x 3/4" Turn Bolt into POWER RAIL and rotate 90-degrees, locking Turn Bolt in place. On the outermost "L" Feet align center of the "L" Foot with the

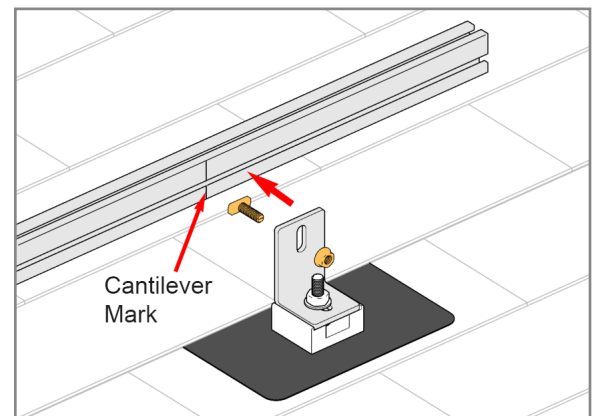

cantilever mark on the POWER RAIL. Secure POWER RAIL to "L" Foot with 5/16" Flange Nut. **Torque to 15 ft.-lbs.**

3 Splicing POWER RAIL with Splice Plates

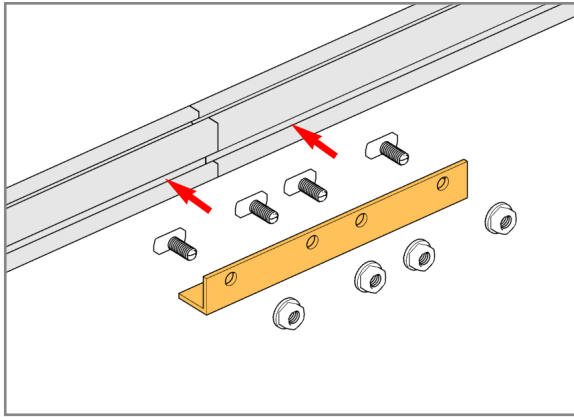

Splice Plates come in two configurations, 2-hole or 4-hole (above is a 4-hole). Insert 5/16" x 3/4" Turn Bolts into POWER RAIL and rotate 90-degrees

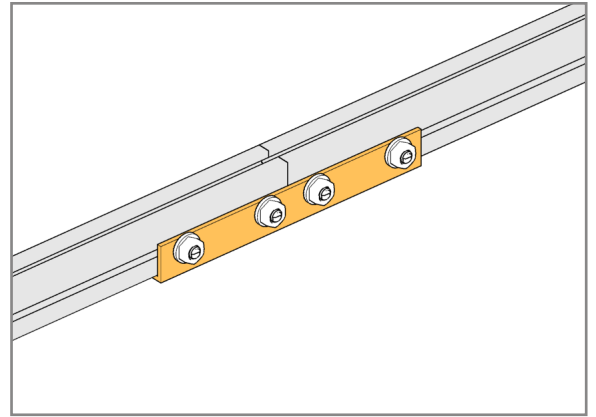

to lock Turn Bolts in place. Align Splice Plate with center of splice and secure to POWER RAIL with 5/16" Flange Nuts. **Torque to 15 ft.-lbs.**

4 Install the Modules

CAUTION

This is a two person activity. In addition to the difficulties associated with working on a sloped rooftop, PV Modules are heavy. One person should hold and align the modules while a second person secures modules with clamping hardware. Failure to do so could lead to serious personal injury and/or damaged components.

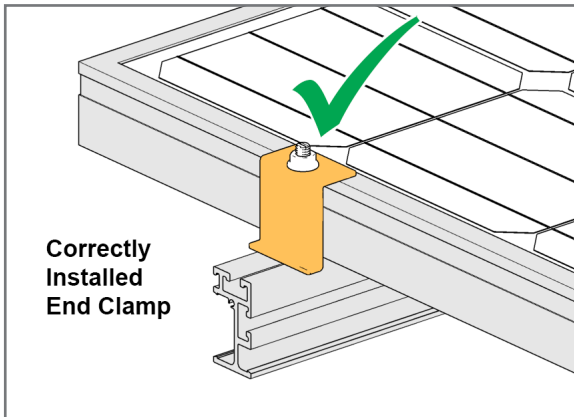

Correctly Installed End Clamp

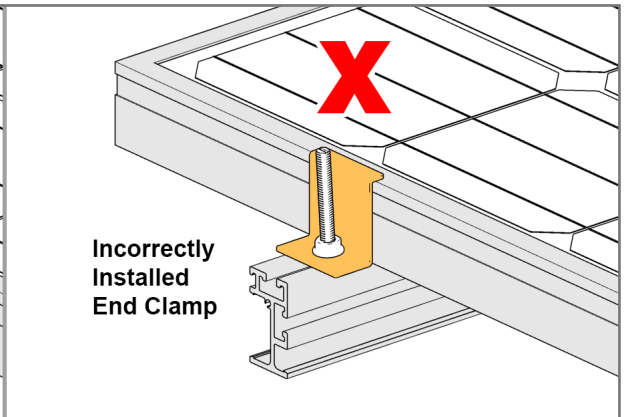

Incorrectly Installed End Clamp

End Clamps must be installed as shown above left, not upside down as shown to the right.

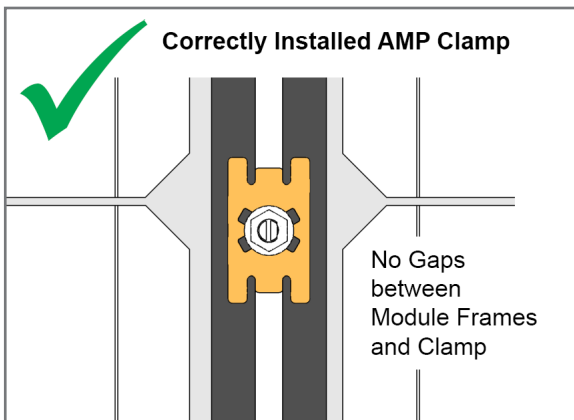

Correctly Installed AMP Clamp

No Gaps between Module Frames and Clamp

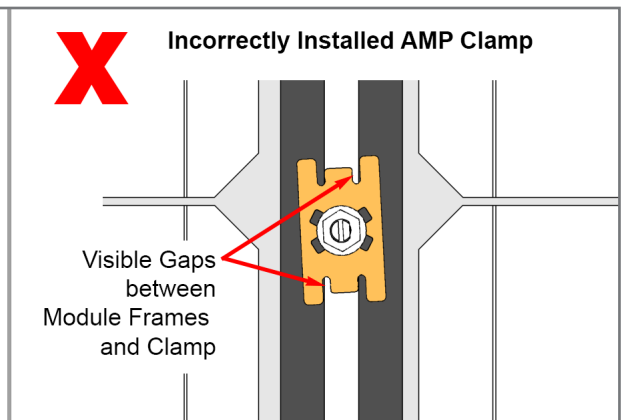

Incorrectly Installed AMP Clamp

Visible Gaps between Module Frames and Clamp

AMP Clamp bonding Mid Clamps must be installed as shown at above left and not as shown to the right. There cannot be any visible gaps between the bonding Mid Clamps and module frames.

4 Install the Modules (cont.)

NOTE

The RAD bolts used in the AMP Clamps and End Clamps must be locked into the channel by rotating clockwise 90-degrees. Use the indicator slot on the threaded end to identify whether or not the bolt has been locked.

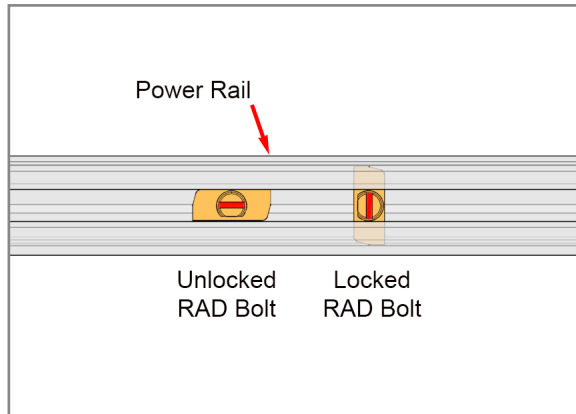

AMP Clamp bonding Mid Clamps are inserted into the POWER RAIL and positioned between adjacent Modules. Insert the 5/16" RAD Bolt into POWER RAIL and rotate

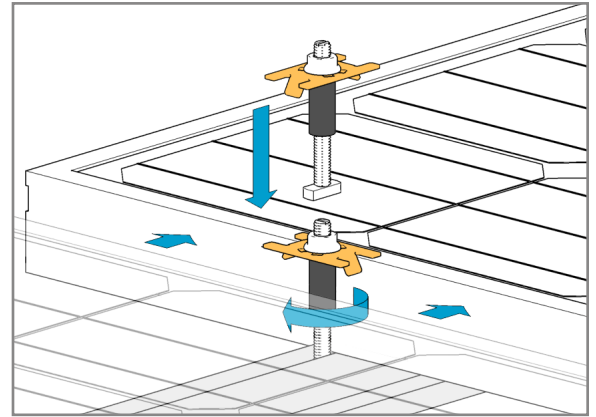

90-degrees clockwise to lock the RAD Bolt within the POWER RAIL. Push Modules against AMP Clamp. Tighten 5/16" Flange Nut. **Torque to 15 ft.-lbs.**

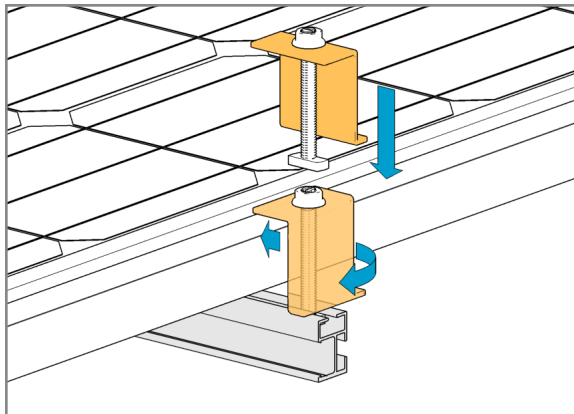

RAD End Clamps are used on the outer Modules. Insert the 5/16" RAD Bolt into POWER RAIL and rotate 90-degrees clockwise to lock the RAD Bolt within the POWER RAIL. Secure with 5/16" Flange Nut. **Torque to 15 ft.-lbs.**

Grounding/Bonding Path Non-Anodized Rails

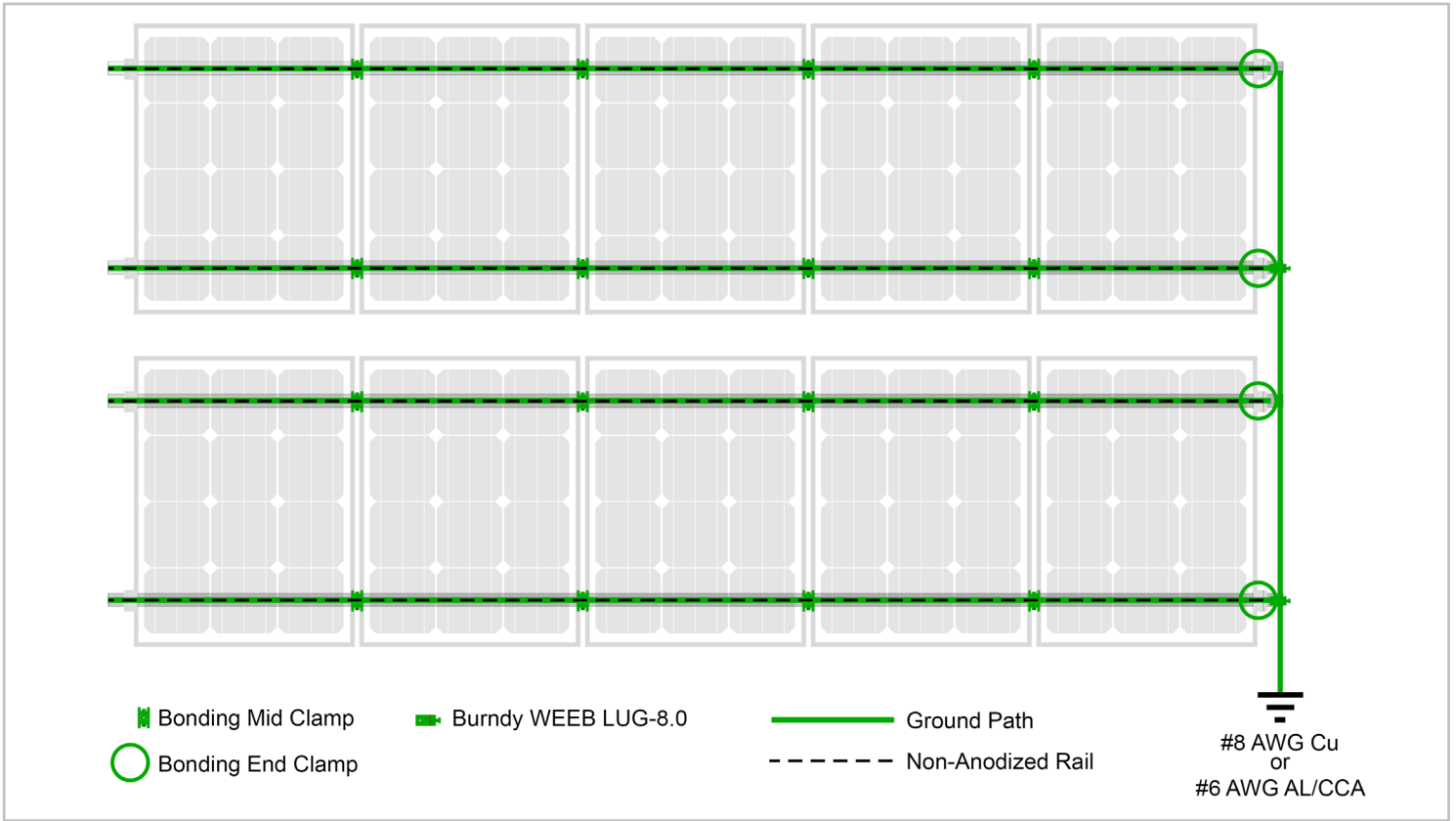

Grounding/Bonding Path Anodized Rails

To maintain a bonding path during maintenance within a module row it is recommended to install a ground wire at this end.

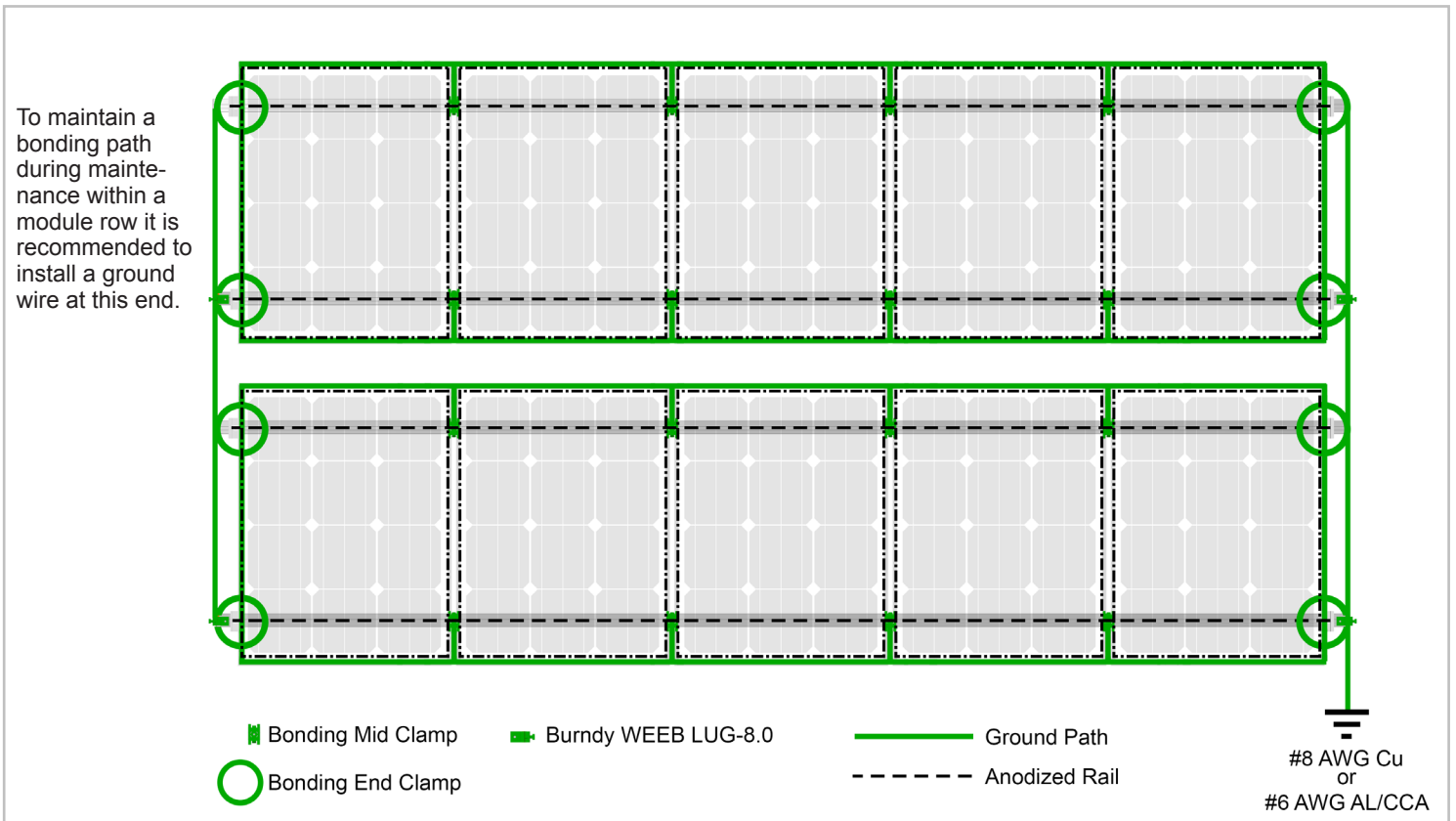

Installing a WEEB-LUG 8.0

IMPORTANT

Before installing verify with the lug manufacturer for any updates or revisions to these lug installation instructions.

One of two mounting methods may be used defined here as Methods A and B.

Lug is suitable for use with 14-6AWG solid or stranded copper conductor when tightened to 5ft-lbs.

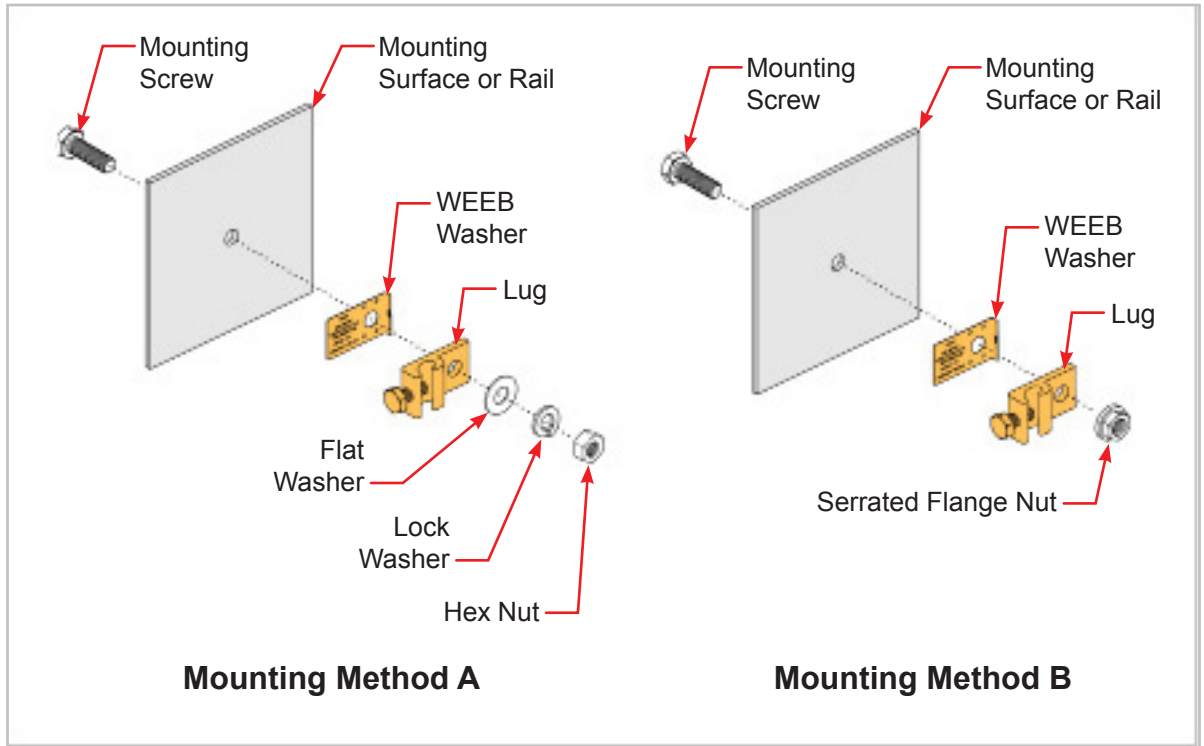

Cat No.	Max OCPD (A)	Mounting Surface					Mounting Screw		Mounting Hole Range	
		Min Profile (w x l)	Min Thick (in)	Max Thick (in)	Mtl	Surface Prep	Size	Tightening torque (lbs.-in)	Min (mm)	Max (mm)
WEEB-LUG-8.0	200	22mm x 20mm	.06"	.25"	AL	Anodized	5/16" M8	120	7.85mm	10mm
			.06"	.25"	Steel	Galvanized				

Table 1: Mounting Surface Requirements

IMPORTANT NOTES

1. Before installing verify with the lug manufacturer for any updates or revisions to these lug installation instructions. The instructions on this page only address the WEEB-LUG-8.0 as found within the manufacturers (Burndy) document number 50016572 Rev E.
2. The NEC section 690.43 states, "Exposed non-current carrying metal parts of module frames, equipment, and conductor enclosures shall be grounded in accordance with 250.134 or 250.136 (A) regardless of voltage."
3. For Proper Equipment Grounding Conductor (EGC) and Overcurrent Protection Device (OCPD) sizing, refer to NEC sections 250.66, 250.122 and 250.166.

Compatible Modules - these modules meet the UL2703 standard

This racking system may be used to ground and/or mount a PV module complying with UL 1703 only when the specific module has been evaluated for grounding and/or mounting in compliance with the included instructions.

Manufacturer	Frame Thickness	Model
Boviet	35 mm	BVM6612M-365, BVM6612M-370, BVM6612M-375, BVM6612M-380
Canadian Solar	40 mm	CS6P-XXX, CS6P-XXXP, CS6P-XXXP-SD,
Hanwha	32 mm	Q.Pro BFR-G4.x XXX, Q.Plus BFR-G4.x XXX, Q.Pro-G4.x XXX, Q.Plus-G4.x XXX, Q.Peak BLK G4.x XXX
	35 mm	Q.Pro L-G4.x XXX, Q.Plus L-G4.x XXX, Q.Peak L-G4.x XXX, Q.Peak Duo BLK G5.x-XXX
Heliene	40 mm	60P-MIM, 60P, 72P
JA Solar	40 mm	JAP72S01-XXX/SC
Japan Solar	35 mm	JS-XXXM-LI60, JPS-XXXM-60,
	40 mm	JS-XXXM-LI72, JPS-XXXM-72, JPS-XXXP-72
Jinko Solar	40 mm	JKMXXXPP-60-V, JKMXXXPP-72-V
Kyocera	46 mm	KUXXX-6BCA
LG	35 mm	LGXXXN1C-G3
	36 mm	LGXXXN2W-B3
	40 mm	LGXXXN1C-G4, LGXXXN2W-A5, LGXXXQ1C-A5
	46 mm	LGXXXN2W-B3, LGXXXN2W-G4
Panasonic	35 mm	VBHXXXXSA11, VBHXXXXSA16
Phono Solar	35 mm	PS275-300P
	40 mm	PS250-275P, PS330-360P
REC Solar	35 mm	RECXXTP, REC285
	38 mm	RECXXXPE, RECXXTP, RECXXTP2, RECXXTP2 BLK2,
Silfab	38 mm	SLAXXM
Solar World	31 mm	SW280 31mm
	33 mm	SW XXX 33 mm, SW XXX XL 33mm FR, SW XXX Mono, SW XXX Mono Black, SW XXX XL Mono Black
Suniva	35 mm	OPT-XXX-60-4-100
	38 mm	OPT-XXX-60-4-100, OPT-XXX-72-4-100
Sunpower	46 mm	SPR-XXXNE-WHT-D, X21-XXX-BLK, E20-Series, P17-Series, SPR-X22-XXX-COM
Suntech	40 mm	STPXXX-24 /Ve, STPXXX-24/Vem
	50 mm	STPXXX-24/Vd
Topoint Solar	35 mm	JTM185-72M, JTM190-72M, JTM195-72M, JTM200-72M
Trina	40 mm	TSM-XXXPD1z4
Winaico	35 mm	WST_XXXPERC, WST-P6



Global Headquarters
660 Beta Drive
Mayfield Village, OH 44143

Telephone: 800.260.3792
Fax: 440.442.8816
preformed.com
Email: info@pipsolar.com

© 2019 Preformed Line Products
SP3411-3