

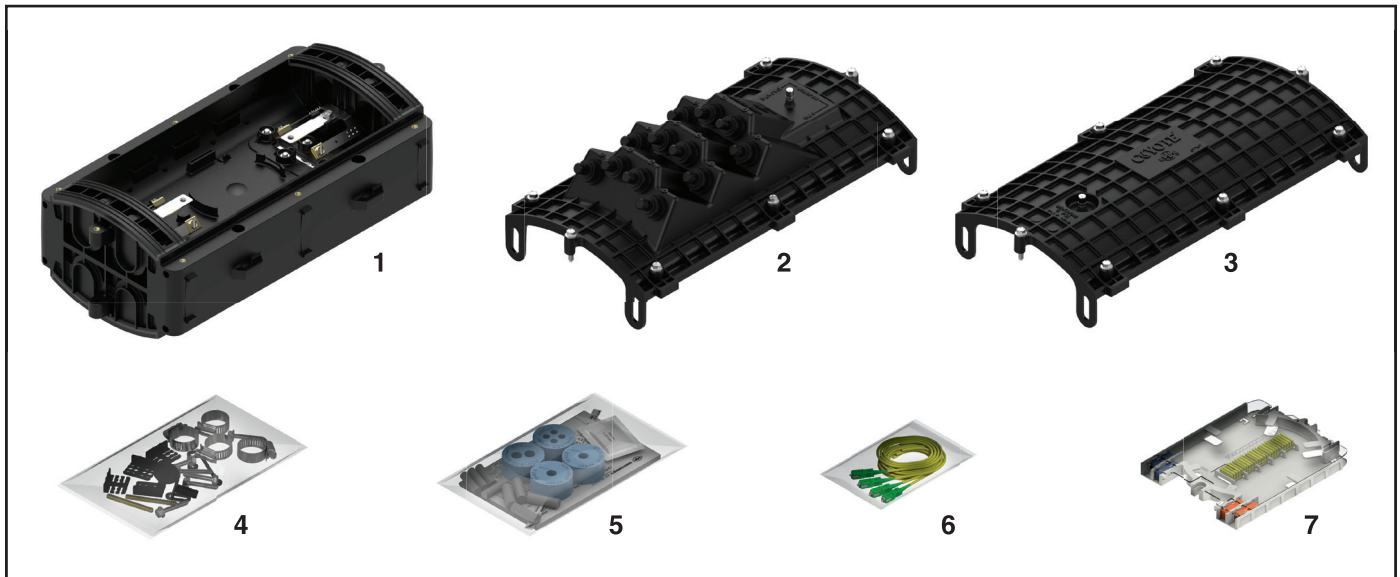

# COYOTE® Terminal Closure - Dual Chamber for Terminal Applications

Be sure to read and completely understand this procedure before applying product. Be sure to select the proper PREFORMED™ product before application.



### NOMENCLATURE

1. Dual Base with End Caps (1)
2. Terminal Cover - 12 Port Shown (1 or 2)
3. Standard Cover (0 or 1)
4. Small Parts Bag (2)
5. Grommet Kit - Includes 4 Grommets (1)
6. Pigtail Kit (1 - 6)
7. Short Deep Profile LITE-GRIP® Splice Tray (2)























### TOOLS REQUIRED

- 3/8" & 7/16" Can wrench or socket wrench
- Side Cutters
- Snips
- Fiber optic cable opening tools
- Utility knife
- Pliers

COYOTE Splice Tray Capacity Chart for COYOTE Dual Chamber Terminal Closures					
PLP Catalog Number	Description	Image	Splice Type	Max Trays per Closure <sup>1</sup>	Closure Max Splice Capacity <sup>1</sup>
80809958	Short Low Profile LITE-GRIP® Splice Tray (24ct)		Single Fusion	8	192
80813152	Short Low Profile LITE-GRIP Splice Tray (36ct)		Single Fusion	8	288
80808945	Short Deep Profile LITE-GRIP Splice Tray (40ct)		Single Fusion	4	160
LGSTR144	Short Deep Profile LITE-GRIP Splice Tray (144ct)		Ribbon/Mass Fusion	4	576

<sup>1</sup>To meet the stated splice tray and splice capacities, order a Drop Chamber Conversion Kit (Catalog Number 8003695).

COYOTE® Dual Chamber Terminal Closure Kits							Description
Catalog No.	Cover 1 Port Qty.	Adapter Qty.	Plug Qty.	Cover 2 Port Qty.	Adapter Qty.	Plug Qty.	
80061029	6	6	0	Standard	N/A	N/A	COYOTE Dual Chamber Terminal Closure Kit - Includes 6 OptiTap™ Adapters
800011830		6	0	6	6	0	COYOTE Dual Chamber Terminal Closure Kit - Includes 12 OptiTap Adapters
8006991	9	8	1	Standard	N/A	N/A	COYOTE Dual Chamber Terminal Closure Kit - Includes 8 OptiTap Adapters
800012140		9	0		N/A	N/A	COYOTE Dual Chamber Terminal Closure Kit - Includes 9 OptiTap Adapters
800012605	12	12	0	12	12	0	COYOTE Dual Chamber Terminal Closure Kit - Includes 24 OptiTap Adapters
800011839	Standard	N/A	N/A	Standard	N/A	N/A	COYOTE Dual Chamber Terminal Closure Kit for Direct Splice Applications
8006956		N/A	N/A		N/A	N/A	COYOTE Dual Chamber Terminal Closure Kit with Internal Bulkhead with 6 SC/APC Adapters
PLP Catalog Number	Description						
Accessory Kits for COYOTE Dual Chamber Terminal Closures							
8003733	End Plate Kit - Includes (1) End Plate, (3) Bolts, & (1) Silicone Packet						
80807794	Hardware Bag Kit						
8003713	Express Bracket Kit - Includes (4) Express Brackets						
8003719	COYOTE In-Line RUNT Cover Kit						
8003862	Fiber Organizer Kit for Ribbon Fibers						
80805293	.13" (3.4 mm) ID Transport Tube Kit - Includes (6) 34" long Transport Tubes for Single Fibers						
80806439	.25" (6.4 mm) ID Transport Tube Kit - Includes (6) 34" long Transport Tubes for Ribbon or Single Fibers						
80807989	100 ft. Roll of .17" (4.3 mm) ID Transport Tubing for Ribbon or Single Fibers						
80807991	100 ft. Roll of .25" (6.4 mm) ID Transport Tubing for Ribbon or Single Fibers						
Mounting Brackets for COYOTE Dual Chamber Terminal Closures							
8003705	Adjustable Offset Aerial Mounting Bracket Kit for Strand Applications						
8003703	Pole/Wall Mounting Bracket Kit						
8003706	Swing Arm for Handhole Applications						

COYOTE Grommet Chart for COYOTE Terminal Closures				
PLP Catalog Number	Cable Range Inches (mm)	Description	Image	Slitting Location
8003691	.40" - .60" (10.2 - 15.2 mm)	1-entry grommet		
8003692	.60" - .85" (15.2 - 21.6 mm)	1-entry grommet		
8003693	.85" - 1.0" (21.6 - 25.4 mm)	1-entry grommet		
*8003694	1.0" - 1.25" (25.4 - 31.8 mm)	1-entry grommet		
8003663	.42" - .60" (10.7 - 15.2mm)	2-entry grommet		
8004065	.250" - .312" (6.4 - 7.9 mm)	4-entry grommet		
8003664	.30" - .43" (7.6 - 10.9 mm)	4-entry grommet		
8003990	.50" - .60" (12.7 - 15.2 mm) .125" - .25" (3.2 - 6.4 mm) and flat drop	4-entry grommet		N/A
8003665	.125" - .25" (3.2 - 6.4 mm) and flat drop	6-entry grommet		
8003676	.42" - .60" (10.7 - 15.2 mm) .125" - .25" (3.2 - 6.4 mm) and flat drop	7-entry grommet		
8004094	.093" - .125" (2.4 - 3.2 mm)	8-entry grommet		
8003677	.125" - .25" (3.2 - 6.4 mm) and flat drop	8-entry grommet		N/A

\*8003694: COYOTE In-Line RUNT Closure and COYOTE Terminal Closures' maximum cable diameter range is 1.20"

## Base Preparation

**Step #1** Remove the end plate caps from the base.



**Step #2** Determine which cable port tabs will need to be removed from the base and score the edges of each tab several times with a utility knife.

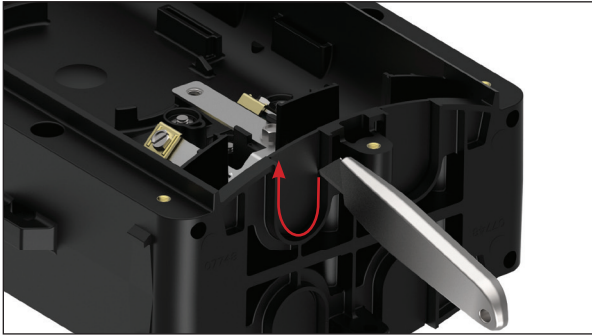

**Step #3** Remove each tab by pulling the tab outwards from the base with pliers.

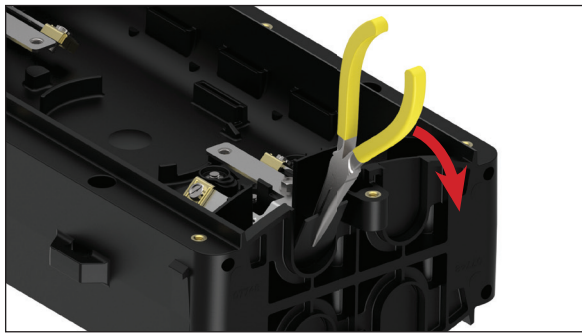

## Feed & Branch Cable Preparation

**Step #4** Measure the cable to determine the diameter and hole location to use in the grommet.

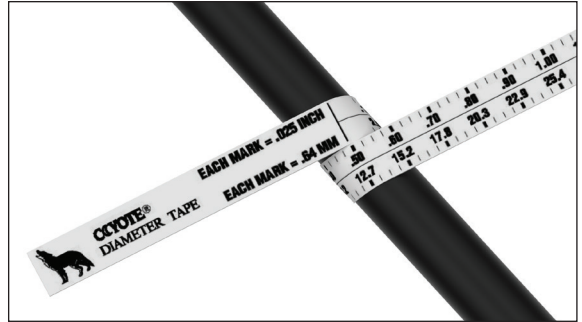

**Step #5** If using cut cable, insert the cable through the grommet. If your application requires express/balloon/ring cut cables, see **Step 7 for the grommet slitting procedure.**

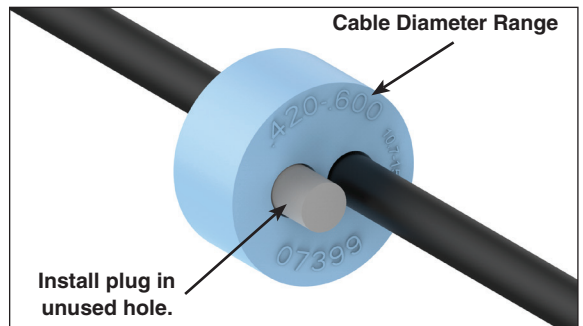

**Step #6** **Installing Figure 8 Style Cables and Cables with Tracer Wires**

Remove the tracer wire or ground wire from the portion of the cable that will be positioned in the grommet and insert the cable into the grommet. Remove any burrs left from removing the tracer wire of the ground wire from the cable.

**Cable with Tracer Wire**

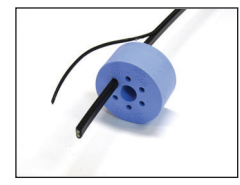
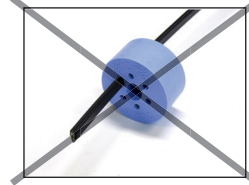

**Figure 8 Style Cable**

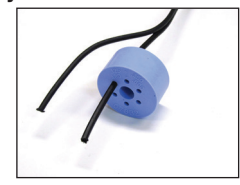
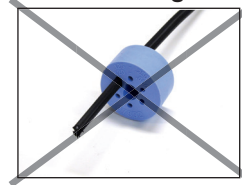

**Step #7 Grommet Slitting** – If slitting is required, lay the grommet on a stable flat surface. Position the utility knife with the cutting edge against the top surface and cut through the grommet. **Consult the grommet chart on page 2 for slitting locations of all grommets.**

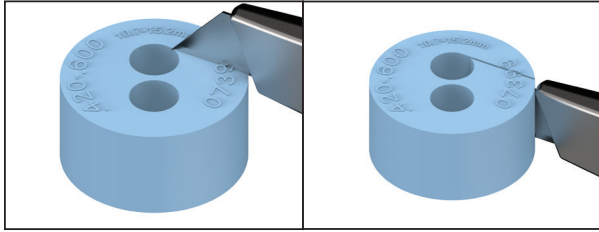

**PLP Tip:** Use a pen to sketch slitting lines on top surface of grommet prior to cutting.

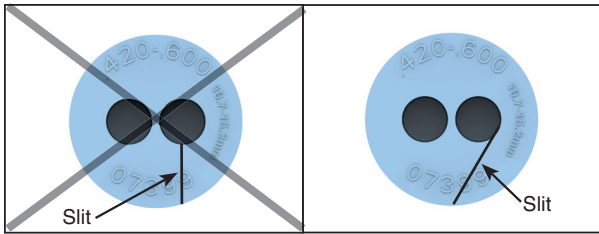

Not Correct Slitting Angle

Correct Slitting Angle

**Step #8** Prepare the feed, branch, and/or drop cable(s) for cut applications.

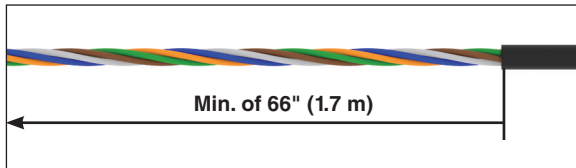

**Minimum Sheath Opening for Cut Cable Applications**

66"	1.7 m
-----	-------

**NOTE:** Leave about 8" (203 mm) of the cable strength member.

**Step #9a** Prepare the feed cable for mid sheath applications (Express/Balloon/Ring Cut).

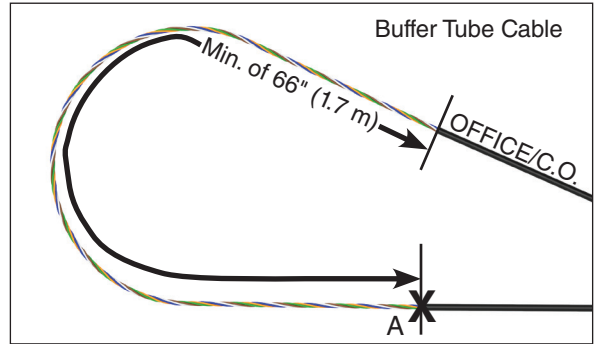

**For Applications Where Fiber is Dedicated to the Splice Point**

Configuration	Cut Location	Sheath Opening
Unitube/Ribbon Expressed (Mid-Sheath)	A	Min of 66" (1.7 m)

**NOTE:** Leave about 8" (203 mm) of the cable strength member.

**Step #9b** Prepare the feed cable for mid sheath applications (Express/Balloon/Ring Cut).

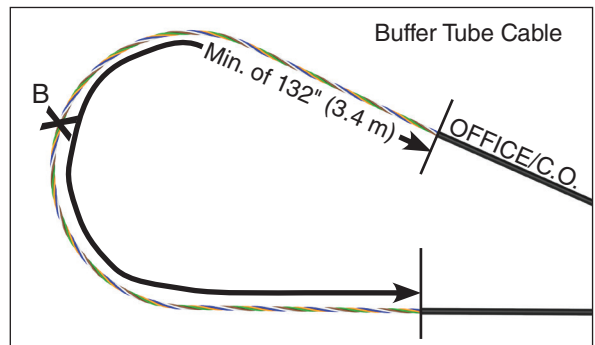

**For Applications Where Fiber is NOT Dedicated to the Splice Point**

Configuration	Cut Location	Sheath Opening
Unitube/Ribbon Expressed (Mid-Sheath)	B	Min of 132" (3.4 m)

**NOTE:** Leave about 8" (203 mm) of the cable strength member.

**Step #10** Trim the cable strength members 1.5" (38mm) from the cable sheath opening.

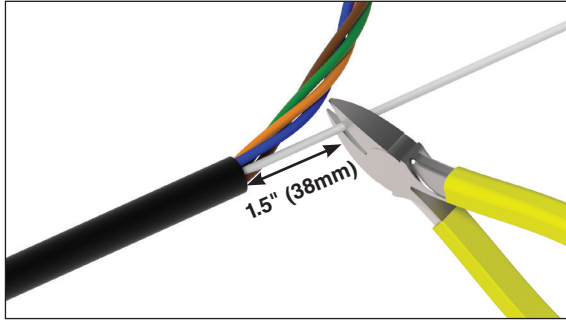

**Step #11** Braid roughly 3" (76 mm) of the aramid yarn and knot the end of it.

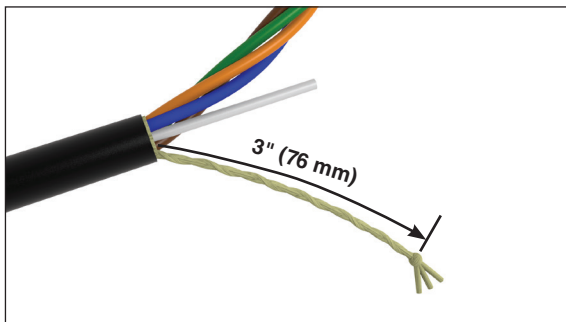

## Cable Grommet Installation

**Step #12** Lubricate the outer surface of each grommet. Spread the lubricant evenly around the outer surface.

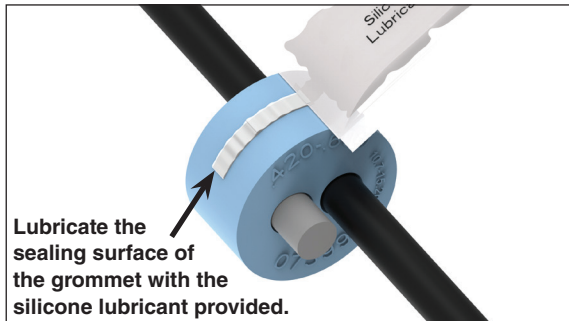

**Step #13a** Position the grommet in the slots of the base.

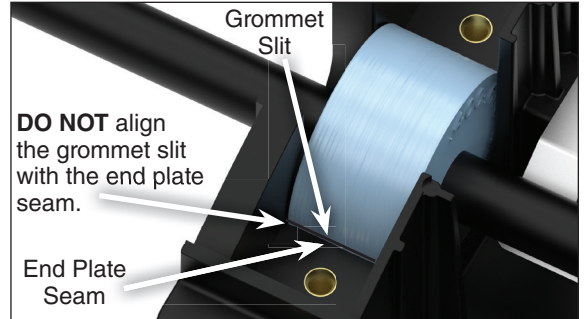
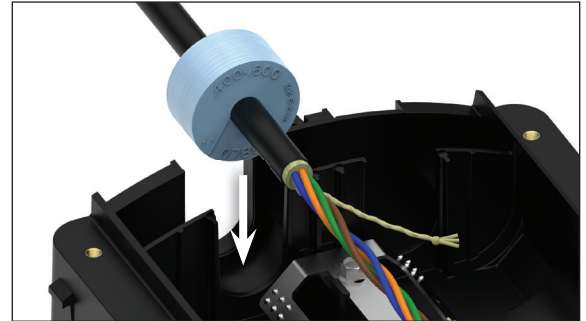

**Step #13b FOR IN-LINE APPLICATIONS**

When only one cable port is being used at an end of the closure, **install a grommet with plugs inserted in it, in the unused cable port.** This will balance the load of the end plate cap.

**NOTE: It is not necessary to break out the tab of the unused port.**

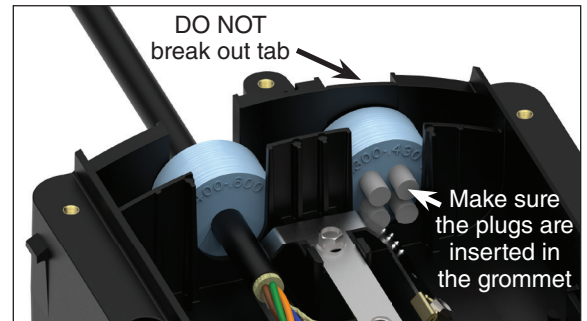

**Step #14** Bend each leg of the cable restraint brackets upward until they contact the cable(s)



**Step #15** Position the cable strength member under the cap of the cable restraint bracket. Wrap the braided aramid yarn around the screw, under the cap and tighten the cap down.

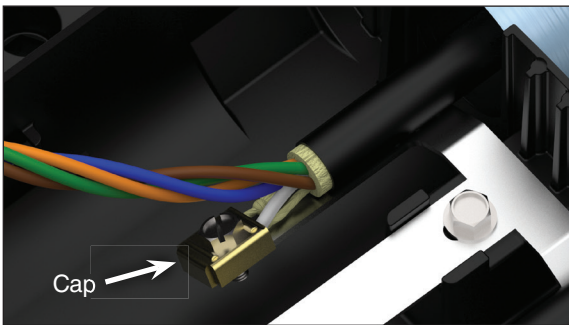

**Step #16** Secure the cables to the cable restraint brackets with the hose clamps provided.

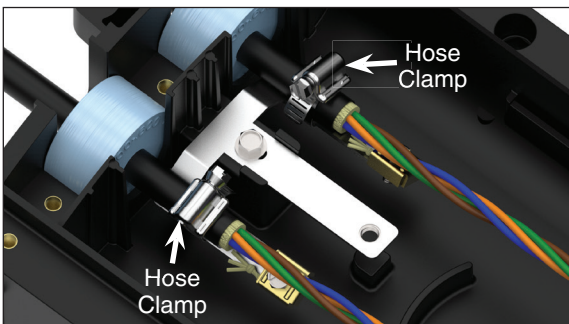

## End Plate Cap Installation

**Step #17** Screw the hex head cap bolts into each end plate cap.



**Step #18** Lubricate the end plate caps with the silicone lubricant that is provided on the areas indicated below.

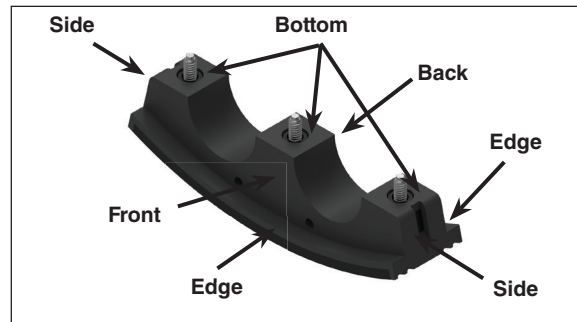

**Step #19a** Install the end plate caps in the pockets of the base. Tighten the bolts of each end plate cap evenly until the end plate cap is fully sealed. **NOTE: DO NOT USE POWER TOOLS TO TIGHTEN THE BOLTS.**

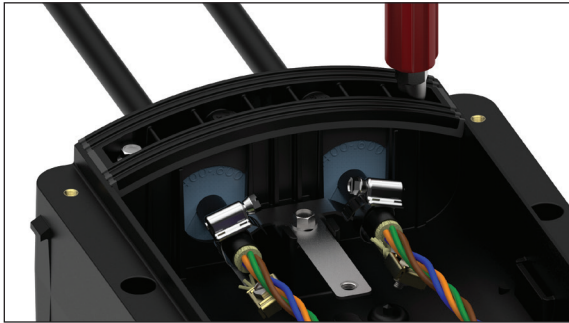

**NOTE:** When both cable ports are not being used at an end of the closure, it is not necessary to install grommets under the blank end plate cap.

**Step #19b** Check to see if the end plate caps are fully seated. The caps will be fully seated when puckering of the sealing surface occurs.

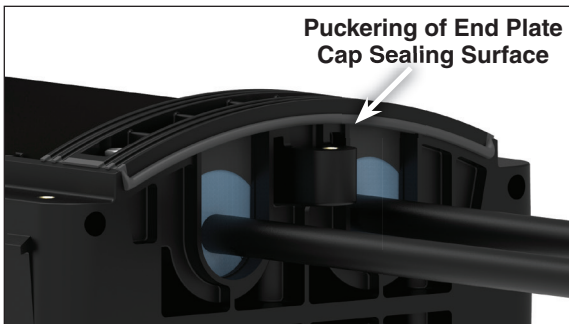

## Buffer Tube Routing

**Step #20** Install the tie down clips in the bottom of the base and route the expressed buffer tubes of the feed cable under the clips as shown below.

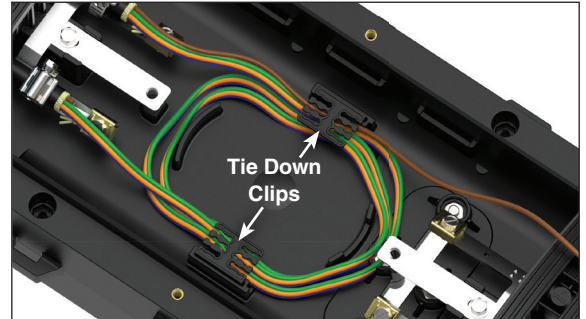

**Step #21a** If splicing is to occur in the same chamber as the express loop, route the feed buffer tube(s) under the tie down clips as shown below. Secure all the buffer tubes to the tie down clips with tie wraps.

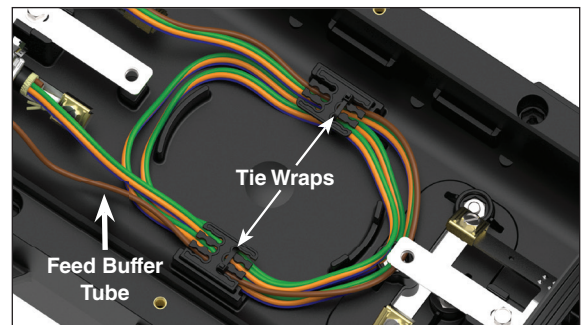

**Step #21b** If splicing is to occur in the opposite chamber as the express loop, route the feed buffer tube(s) through the window of the base and under the tie down clip in the other chamber. Secure all the buffer tubes to the tie down clips with tie wraps.

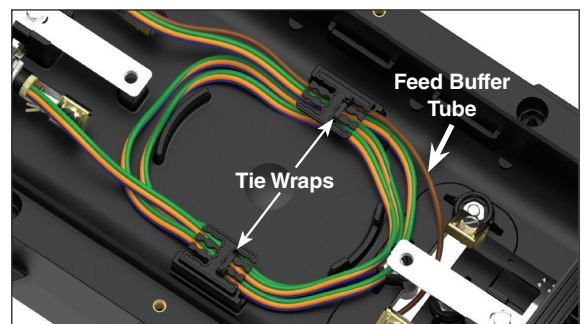

**Step #21b Continued**

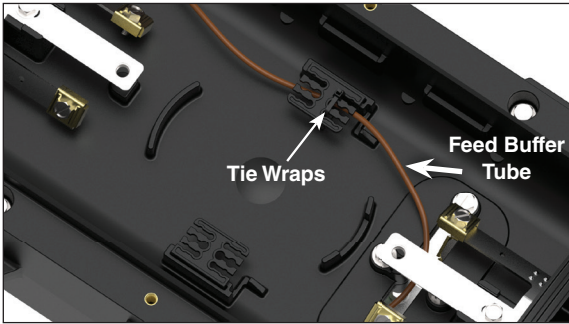

**Step #24** Place the splice tray onto the organizer studs and route the buffer tube(s) to the splice tray.

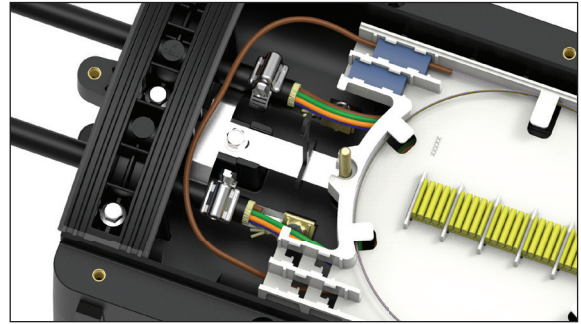

**Step #22** Install the splice tray restraint straps onto the cable restraint brackets.

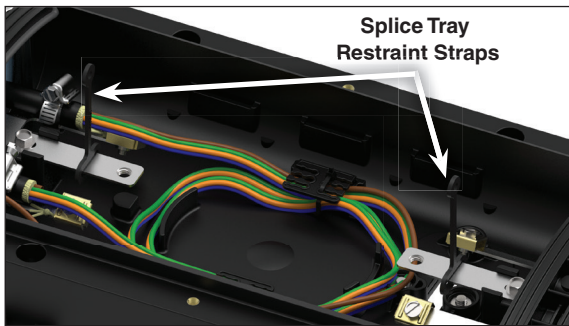

**Step #25** Measure and mark each pigtail as shown below. Remove the jacket of each pigtail beyond the marked location.

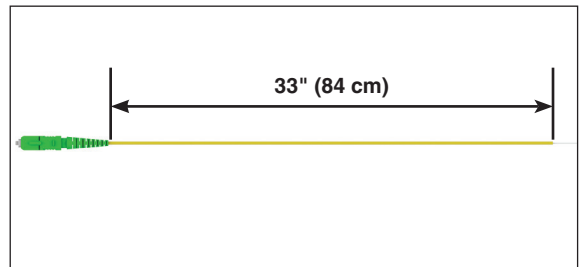

**Step #23** Install the organizer studs into the cable restraint brackets.

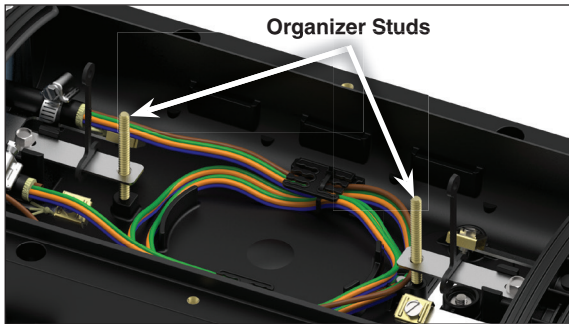

**Step #26** Install the pigtails into the LITE-GRIP® sleeves and install the sleeves into the channels of the splice tray.

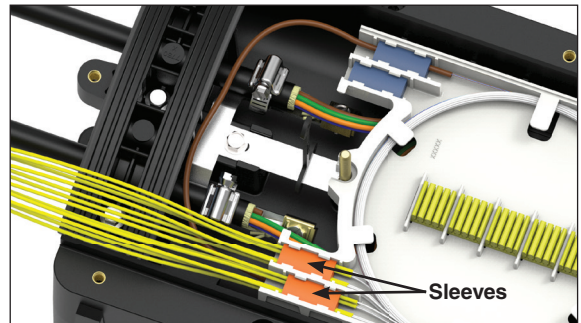



## Splice Tray Management

**Step #27** Route **INCOMING** fibers in the splice tray.

**Fibers  
1 - 12  
21 - 32**

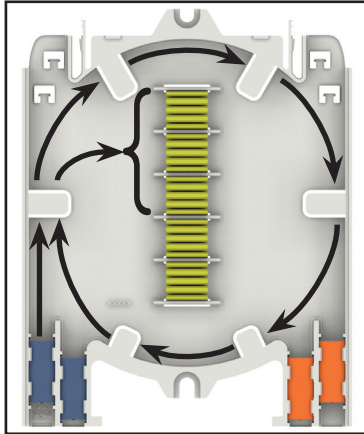

**Fibers  
13 - 20  
33 - 40**

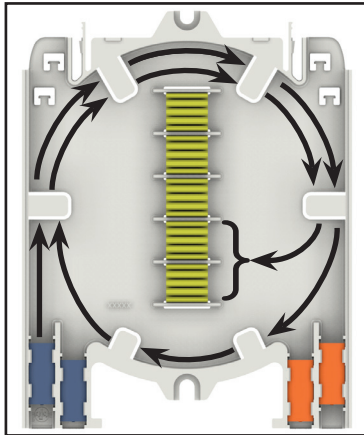

**Step #28** Route **OUTGOING** fibers in the splice tray.

**Fibers  
1 - 12  
21 - 32**

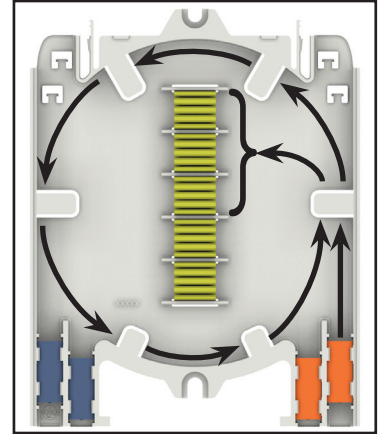

**Fibers  
13 - 20  
33 - 40**

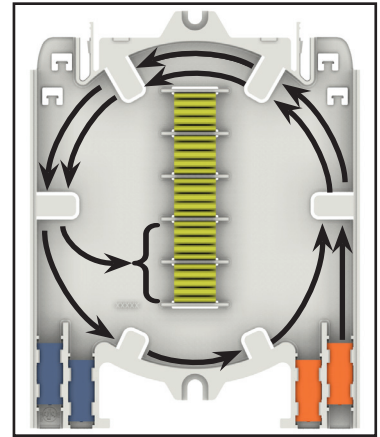

**Step #29** Splice the **INCOMING** fibers to the outgoing fibers per your accepted company practice.

**Step #30** Secure the splice tray with the splice tray restraint straps.

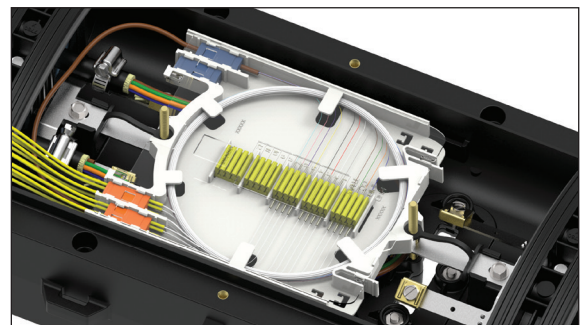

## Cover Installation

**Step #31** Lubricate the cover gasket with the silicone lubricant provided.

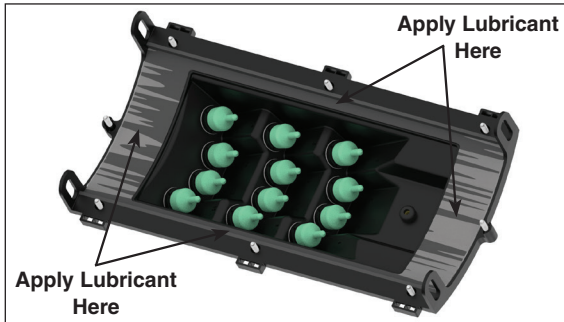

**Step #32** Attach the cover to the base with the hinge posts.

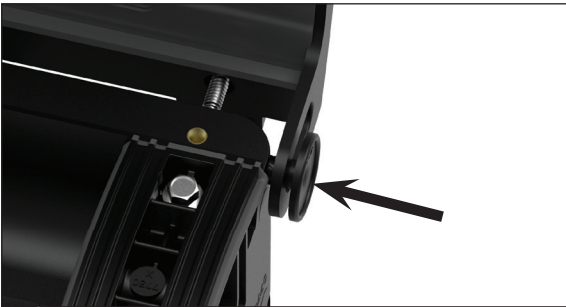

**NOTE:** Make sure that the hinge posts are installed on the opposite side from where the pigtails are exiting the splice tray.

**Step #33** Remove the covers from the hardened adapters that will be used.

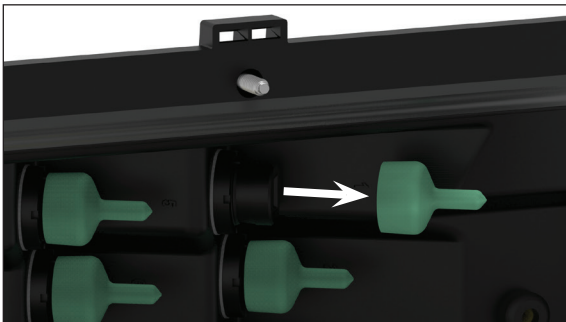

**Step #34** Route the pigtails to the hardened adapters of the cover as shown below and insert the connectors into the adapters.



**NOTE:** Make sure to align the tab of the connector with the slot of the adapter when inserting the connector into the adapter.

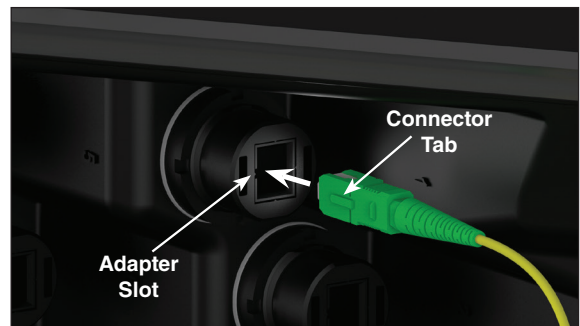

**Step #35** Secure the cover to the base by hand tightening the hex head bolts.  
**NOTE: DO NOT USE POWER TOOLS TO TIGHTEN THE BOLTS.**

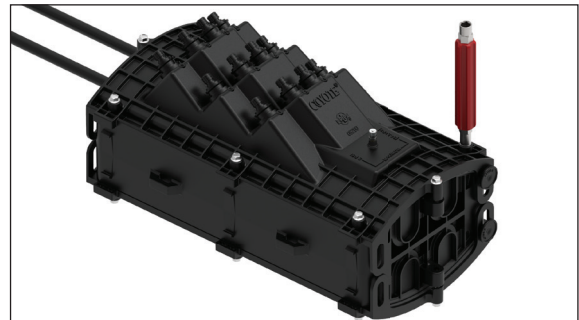

**Step #36** Retighten all of the bolts to ensure the cover is fully seated on the base.

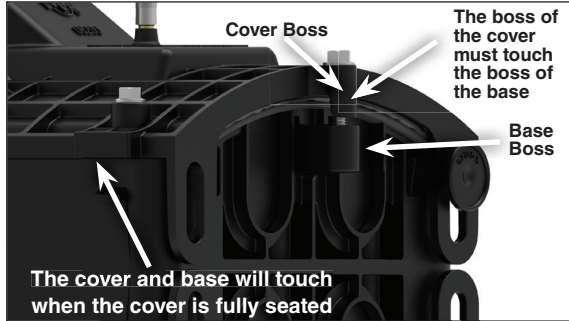

**Step #39** Spray all of the sealing surfaces of the closure with soapy water to determine if there are any leaks.

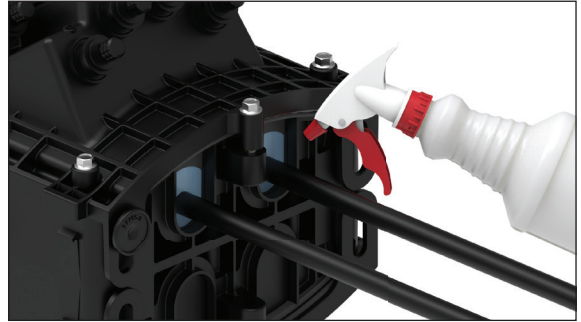

### Flash Test Procedure

**Step #37** Remove the cap from the air valve of the cover.



**Step #40** Release the pressure in the closure using the bump on the top of the air valve cap.



**Step #38** Pressurize the closure up to a maximum of 5 psi.



**Step #41** Install the cap back onto the air valve.



## Drop Cable Installation

**Step #42** Align the arrow of the connector with the notch of the adapter and insert the connector into the adapter.

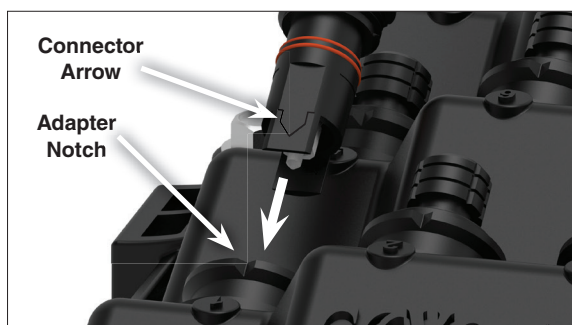

**Step #43** Rotate the threaded sleeve of the connector until it is secured into the adapter.



## Aerial Mounting Bracket Installation

**Step #44** **COYOTE® Terminal Closure (Dual Chamber) Adjustable Offset Aerial Mounting Bracket Kit for Strand Applications (PLP Cat.#: 8003705)**

Assemble the aerial brackets to the mounting bracket as shown below.

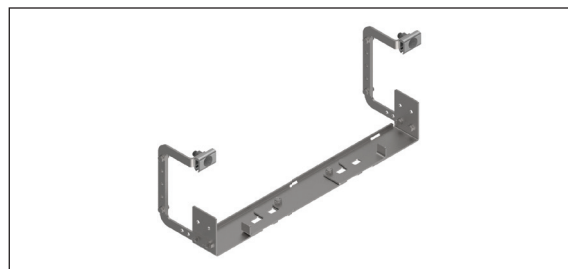
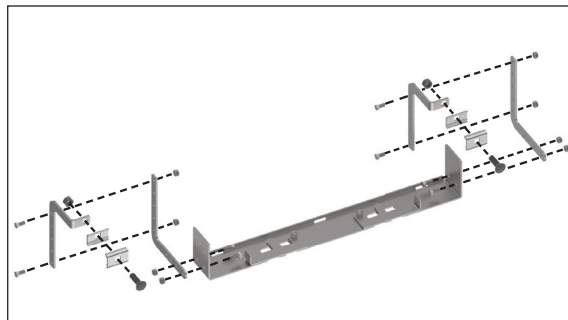

**Step #45** **COYOTE Terminal Closure (Dual Chamber) Adjustable Offset Aerial Mounting Bracket Kit for Strand Applications (PLP Cat.#: 8003705)**

Open up the swivel brackets of the mounting bracket and slide the tabs of the mounting bracket through the side mounting tabs of the closure base as shown in the first image below. Close the swivel brackets to secure the mounting bracket to the closure as shown in the second image below.

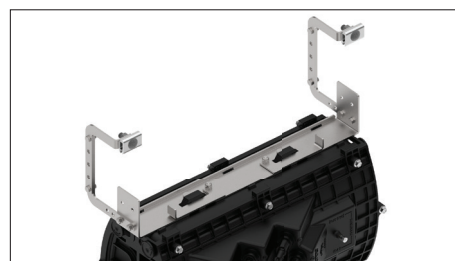
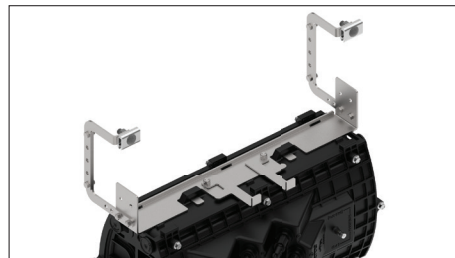

**Step #46 COYOTE® Terminal Closure (Dual Chamber) Adjustable Offset Aerial Mounting Bracket Kit for Strand Applications (PLP Cat.#: 8003705)**

Mount the closure to the strand with the bug nuts of the aerial mounting bracket.

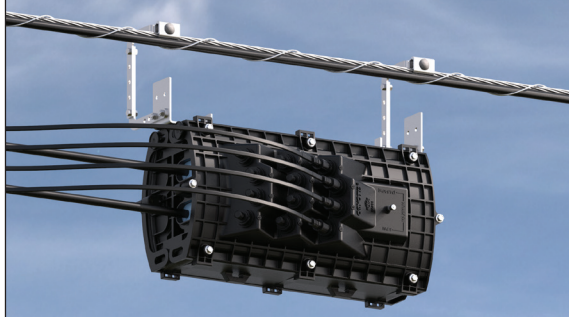

**Pole/Wall Mounting Bracket Installation**

**Step #47 COYOTE® Terminal Pole/Wall Mounting Bracket Kit (PLP Cat.#: 8003703)**

Secure the mounting bracket to the pole/wall with either bolts or banding per your company practice.

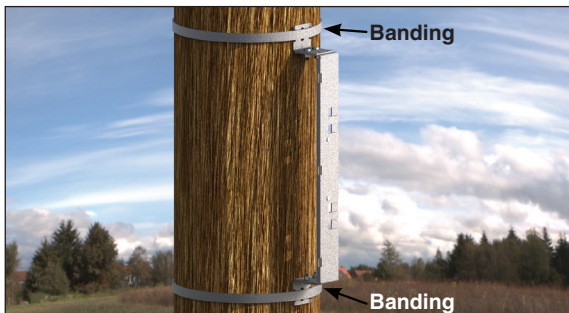
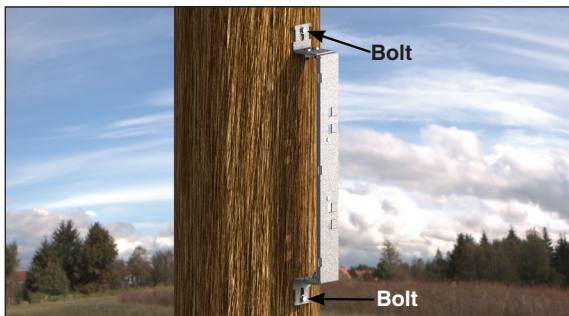

**Step #48 COYOTE Terminal Pole/Wall Mounting Bracket Kit (PLP Cat.#: 8003703)**

Open up the swivel brackets of the mounting bracket and slide the side mounting tabs of the closure base over the tabs of the mounting bracket as shown in the first image below. Close the swivel brackets to secure the closure to the mounting bracket as shown in the second image below.



**Step #49 COYOTE® Terminal Pole/Wall Mounting Bracket Kit (PLP Cat.#: 8003703)**

Completed installation of pole/wall mounting bracket as shown below.



## Swing Arm Installation

### Step #50 COYOTE® Terminal Closure Swing Arm for Handhole Applications (PLP Cat.#: 8003706)

Raise the arm of the swing arm to the upright position as shown below.

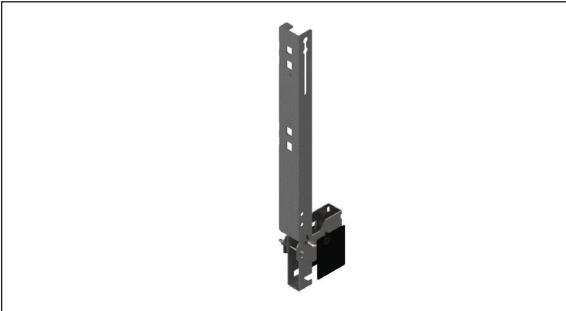
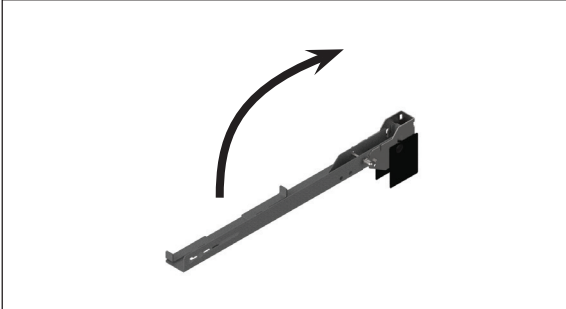

### Step #51 COYOTE® Terminal Closure Swing Arm for Handhole Applications (PLP Cat.#: 8003706)

Insert the carriage bolts through the mounting bracket of the swing arm as shown below.

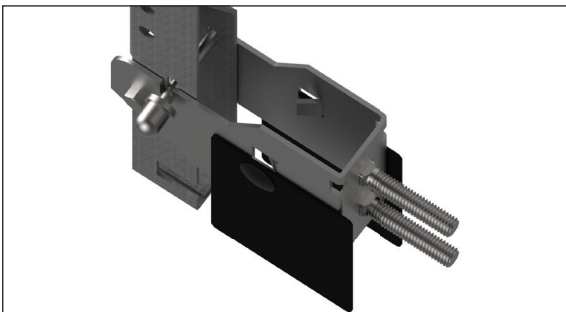
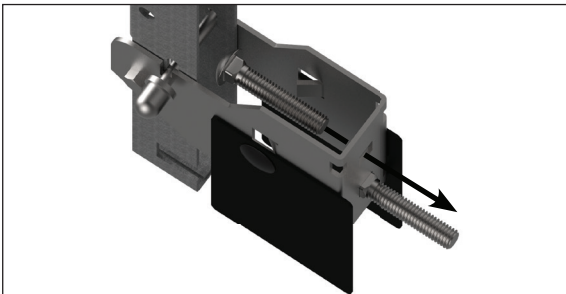

### Step #52 COYOTE® Terminal Closure Swing Arm for Handhole Applications (PLP Cat.#: 8003706)

Dig a small hole on the outside of the installed handhole to locate a flat area on both the inner and outer surfaces of the handhole. Make sure that area is near the top of the handhole and has a wall thickness no larger than 1.5" (38 mm)



### Step #53 COYOTE® Terminal Closure Swing Arm for Handhole Applications (PLP Cat.#: 8003706)

Use the outer bolt support plate as a guide to drill two 3/8" holes through the flat area of the handhole as shown below.

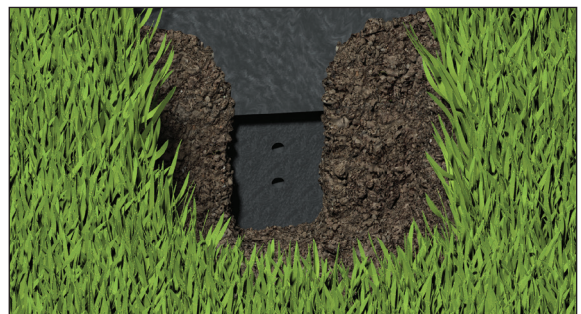

**Step #54 COYOTE® Terminal Closure Swing Arm for Handhole Applications (PLP Cat.#: 8003706)**

Insert the carriage bolts of the swing arm through the drilled out holes of the handhole.

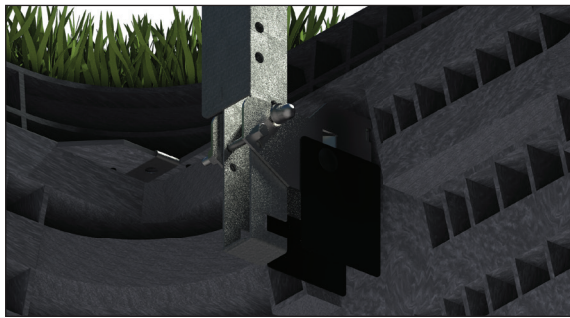
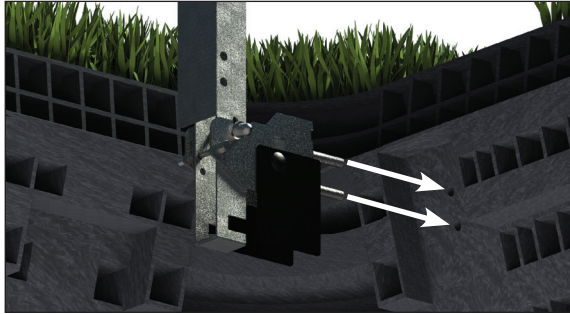

**Step #55 COYOTE® Terminal Closure Swing Arm for Handhole Applications (PLP Cat.#: 8003706)**

Insert the outer bolt support plate over the carriage bolts on the outside surface of the handhole and secure the swing arm with the lock nuts provided.



**Step #56 COYOTE® Terminal Closure Swing Arm for Handhole Applications (PLP Cat.#: 8003706)**

Open up the swivel brackets of the swing arm and slide the side mounting tabs of the closure base over the tabs of the swing arm as shown in the first image below. Close the swivel brackets to secure the closure to the swing arm as shown in the second image below.

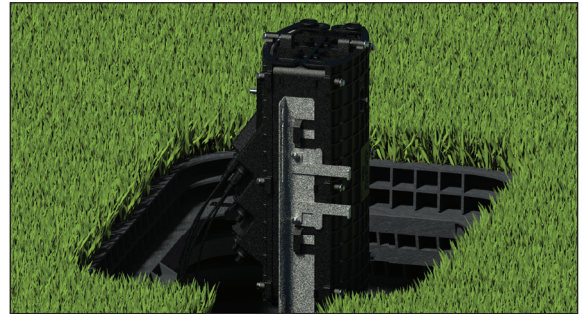

**Step #57 COYOTE® Terminal Closure Swing Arm for Handhole Applications (PLP Cat.#: 8003706)**

Push up on the locking lever to release the arm and pivot it downward into the handhole.

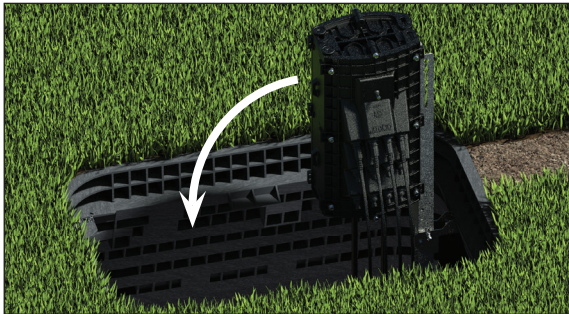
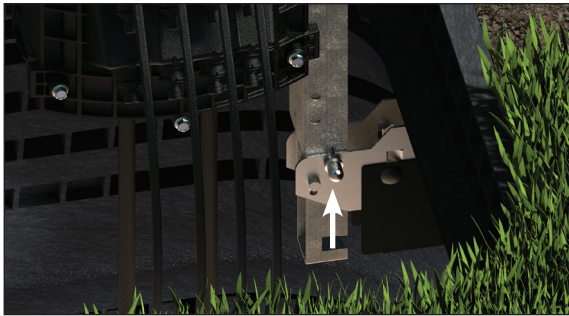

**Step #58 COYOTE® Terminal Closure Swing Arm for Handhole Applications (PLP Cat.#: 8003706)**

Completed installation of swing arm.



**SAFETY CONSIDERATIONS**

This application procedure is not intended to supersede any company construction or safety standards. This procedure is offered only to illustrate safe application for the individual.

**FAILURE TO FOLLOW THESE PROCEDURES MAY RESULT IN PERSONAL INJURY OR DEATH.**

**Do not modify this product under any circumstances.**

This product is intended for use by trained technicians only. **This product should not be used by anyone who is not familiar with, and not trained to use it.**

When working in the area of energized lines, extra care should be taken to prevent accidental electrical contact. Be sure to wear proper safety equipment per your company protocol.

For proper performance and personal safety, be sure to select the proper size PREFORMED™ product before application.

PREFORMED products are precision devices. To ensure proper performance, they should be stored in cartons under cover and handled carefully.



**PREFORMED** LINE PRODUCTS

P.O. Box 91129, Cleveland, Ohio 44101 • 440.461.5200 • [preformed.com](http://preformed.com) • [inquiries@preformed.com](mailto:inquiries@preformed.com)

SP3578-1