

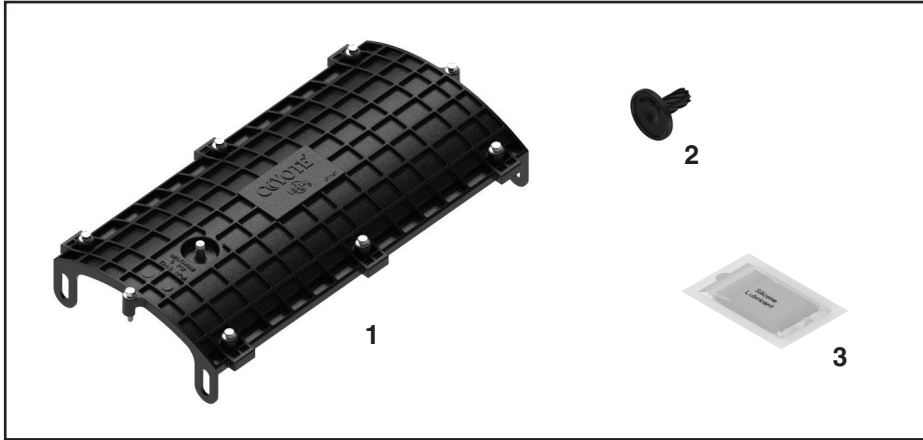

COYOTE® In-Line RUNT Closure Cover Kit

Be sure to read and completely understand this procedure before applying product. Be sure to select the proper PREFORMED™ product before application.



NOMENCLATURE

- 1. Cover with Air Valve (1)
- 2. Hinge posts (2)
- 3. Silicone Lubricant Packets (5g) (2)

TOOLS REQUIRED

- 3/8" & 7/16" can wrench or socket wrench

Step #1 Lubricate the cover gasket with the silicone lubricant provided.

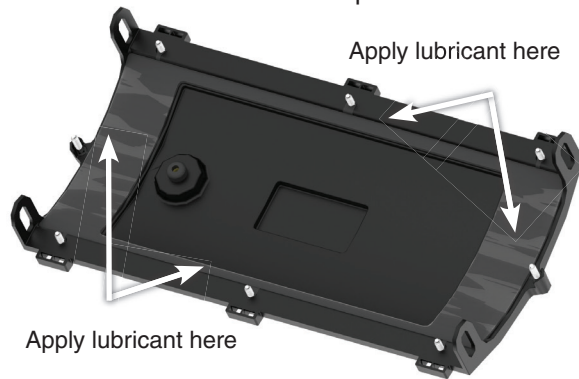

Step #3 Create optional hinge on cover by pushing hinge posts into opposite corners.



Step #2 Retighten all the bolts to ensure the cover is fully seated on the base.

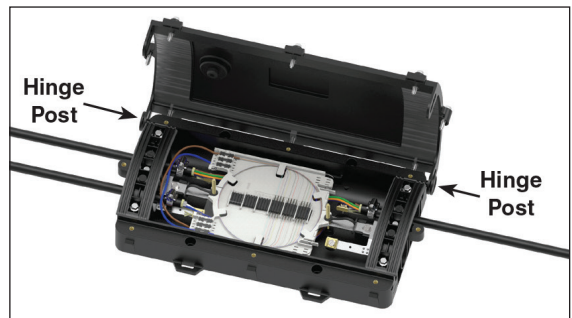
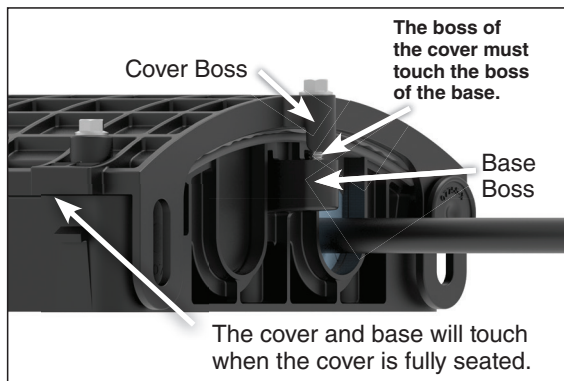

SAFETY CONSIDERATIONS

This application procedure is not intended to supersede any company construction or safety standards. This procedure is offered only to illustrate safe application for the individual. **FAILURE TO FOLLOW THESE PROCEDURES MAY RESULT IN PERSONAL INJURY OR DEATH.**

Do not modify this product under any circumstances.

This product is intended for use by trained technicians only. **This product should not be used by anyone who is not familiar with, and not trained to use it.**

When working in the area of energized lines, extra care should be taken to prevent accidental electrical contact.

For proper performance and personal safety, be sure to select the proper size PREFORMED™ product before application.

PREFORMED products are precision devices. To ensure proper performance, they should be stored in cartons under cover and handled carefully.



PREFORMED LINE PRODUCTS

P.O. Box 91129, Cleveland, Ohio 44101 • 440.461.5200 • preformed.com • email: inquiries@preformed.com