

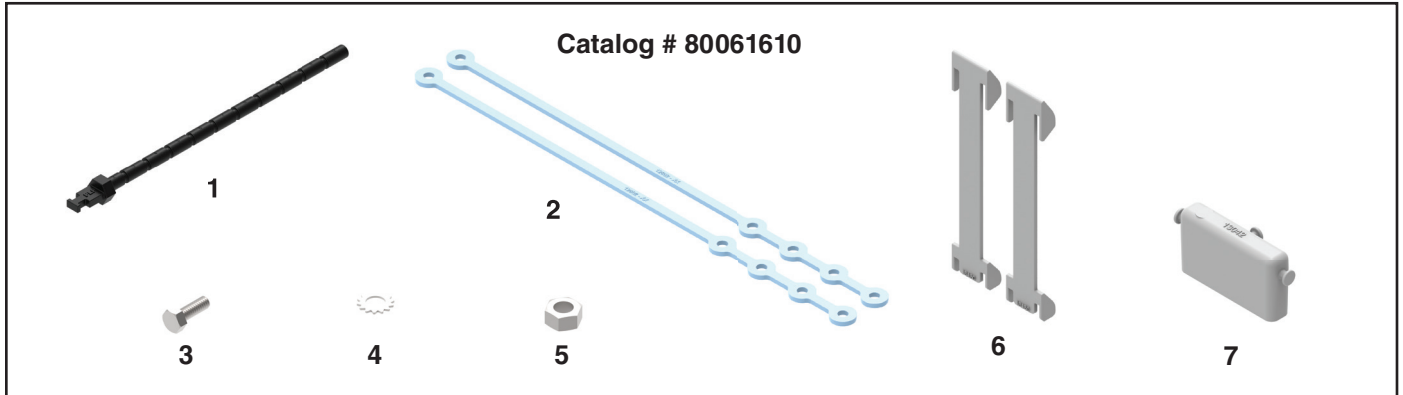

COYOTE® 9.5" x 28" Dome Closure Max Capacity Retrofit Kit

Be sure to read and completely understand this procedure before applying product. Be sure to select the proper PREFORMED™ product before application.



NOMENCLATURE

- 1. Retention Pin (1)
- 2. Tray Retention Strap (2)
- 3. Bolt (1)
- 4. Washer (1)
- 5. Nut (1)
- 6. Storage Bracket Spacer (2)
- 7. Organizer Bar Support Block (1)

Step #1 Remove the tray towers by unscrewing the bolts attaching them to the organizer bar, then removing the fasteners and the towers from the assembly.

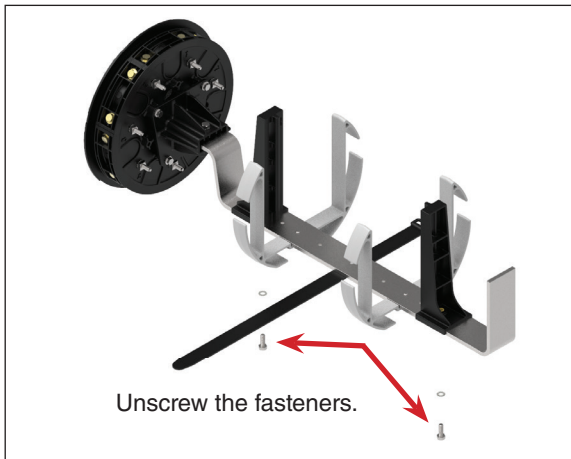

Step #1 Continued.



Step #2 Place the support block onto the end of the organizer bar by pressing down on the block by hand until it is secured.

NOTE: Make sure the middle button tab on the block is facing inwards towards the end plate.



Step #3 Slide the storage bracket spacers onto the two sides of the storage bracket closest to the end plate. The tabs on the spacers should be inserted into the holes in the brackets.

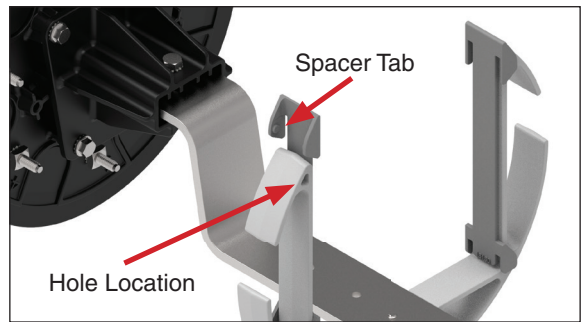
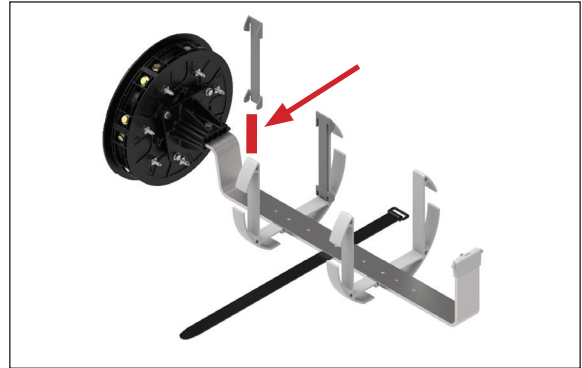

Step #4 Install the hinge bracket to the organizer bar with the 1/4"-20 x 3/4" bolt, lock washer, and the 1/4"-20 hex nut.

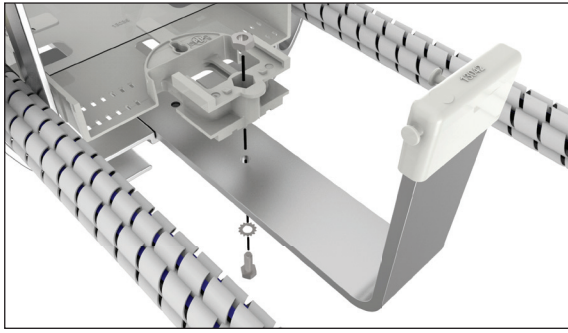

Step #5 To secure the splice trays while they are flipped up, attach the tethers from the button tabs of the tether bracket to the button tabs of the bottom splice tray that is flipped up.

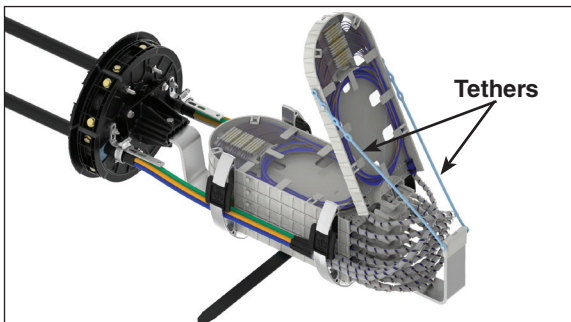
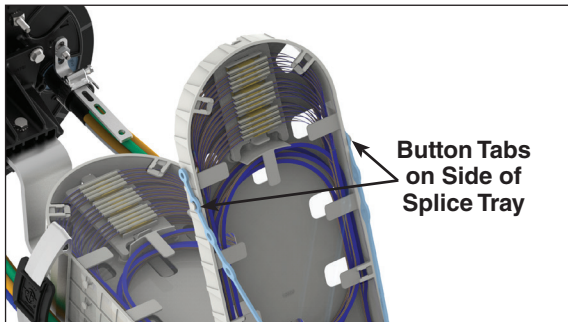
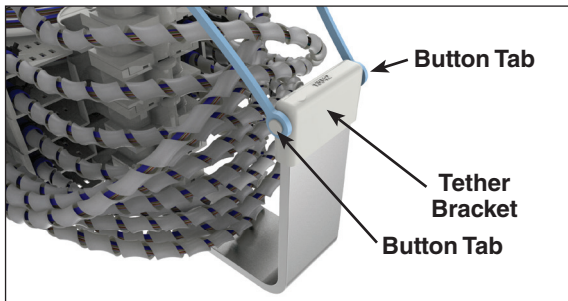

Step #6 When the tethers are not being used, they can be stored on the tether bracket by securing the loose ends of the tethers to the middle button tab as shown below.

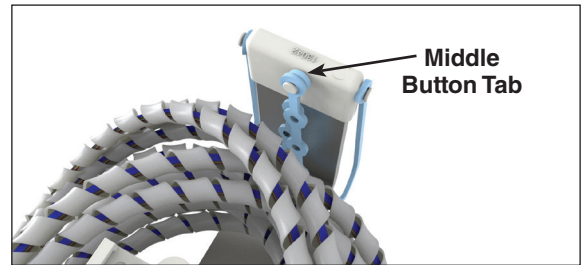

Step #7 Determine the number of splice trays that are installed in the organizer and locate the corresponding number on the lock pin. Trim the lock pin at the notched location just below the number.

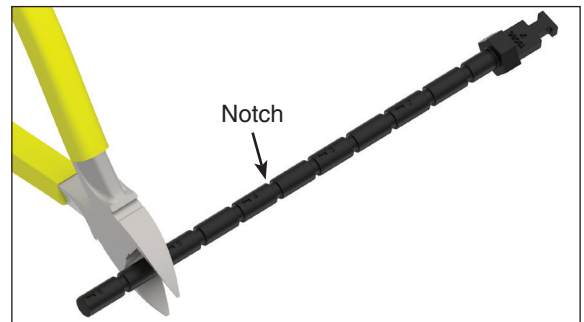

NOTE: One side of the lock pin is numbered 1-12 for thin profile splice trays and the other side of the lock pin is numbered 1-6 for deep profile splice trays.

Step #8 Install the lock pin into the hinge brackets as shown below.

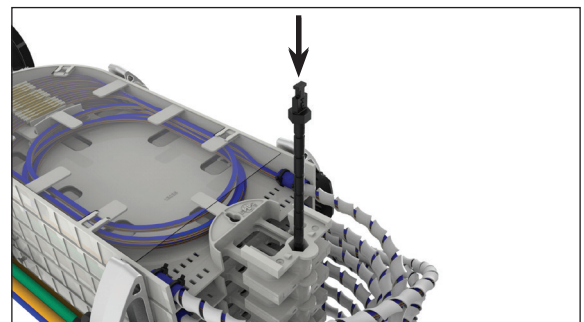

SAFETY CONSIDERATIONS

This application procedure is not intended to supersede any company construction or safety standards. This procedure is offered only to illustrate safe application for the individual.

FAILURE TO FOLLOW THESE PROCEDURES MAY RESULT IN PERSONAL INJURY OR DEATH.

Do not modify this product under any circumstances.

This product is intended for use by trained technicians only. **This product should not be used by anyone who is not familiar with, and not trained to use it.**

When working in the area of energized lines, extra care should be taken to prevent accidental electrical contact. Be sure to wear proper safety equipment per your company protocol.

For proper performance and personal safety, be sure to select the proper size PREFORMED™ product before application.

PREFORMED products are precision devices. To ensure proper performance, they should be stored in cartons under cover and handled carefully.



PREFORMED LINE PRODUCTS

P.O. Box 91129, Cleveland, Ohio 44101 • 440.461.5200 • preformed.com • email: inquiries@preformed.com

SP3592