

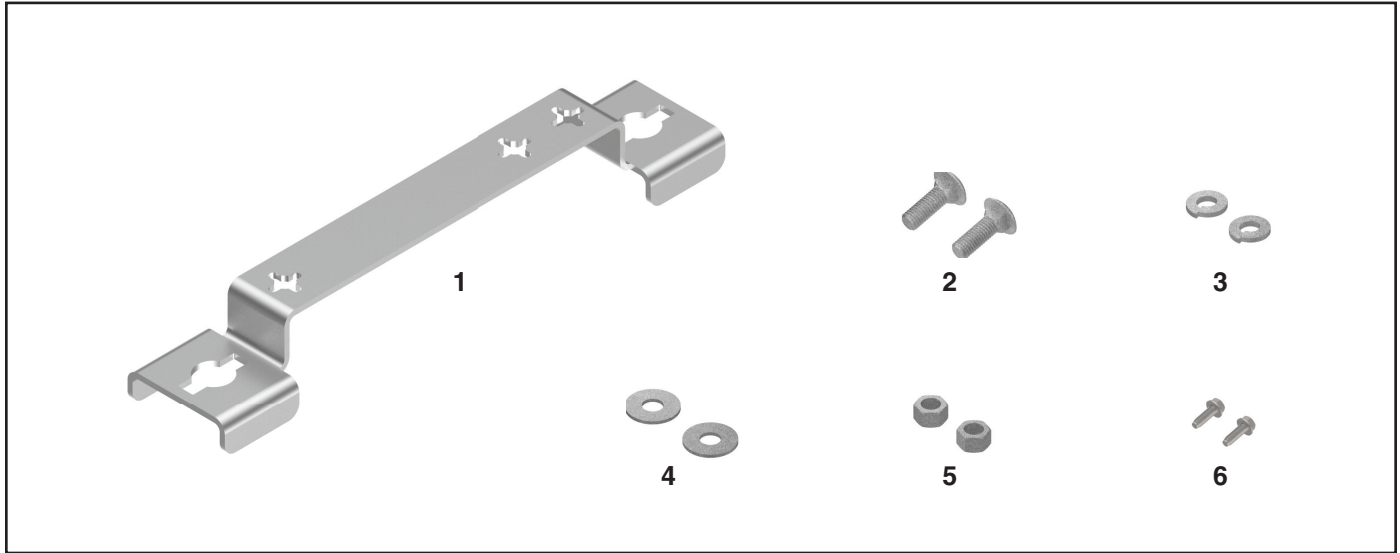

COYOTE® DTC4/6/8 Mounting Bracket for FIBERLIGN® ADSS Cable Storage Bracket

Be sure to read and completely understand this procedure before applying product. Be sure to select the proper PREFORMED™ product before application.



NOMENCLATURE

1. COYOTE DTC4/6/8 Mounting Bracket (1)
2. 1/2"-13 - 1-1/2" HDG Bolts (2)
3. 1/2" Lock Washers (2)
4. 1/2" Washers (2)
5. 1/2"-13 Nuts (2)
6. 1/4"-20 - 3/4" SS Self-Tapping Bolts (2)

PLP Catalog Number	Description
8004072E	FIBERLIGN ADSS Cable Storage Bracket Kit
8004172	COYOTE DTC4/6/8 Mounting Bracket Kit for FIBERLIGN ADSS Cable Storage Bracket Kit

FIBERLIGN ADSS Cable Storage Bracket Assembly (Not Provided)

Step #1 Assemble the crossarms together with the 1/2" bolts, lock washers, washers, and nuts at the intersection of the crossarms as shown below.

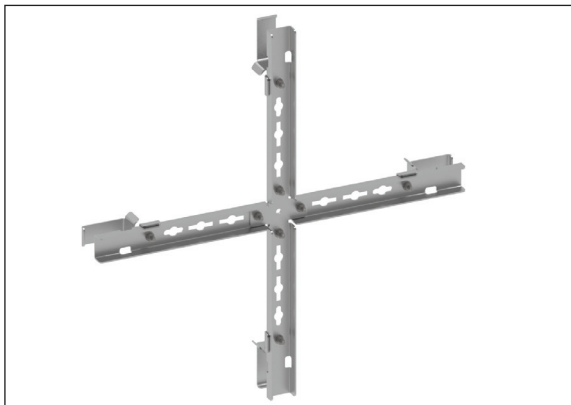

Step #1 Continued

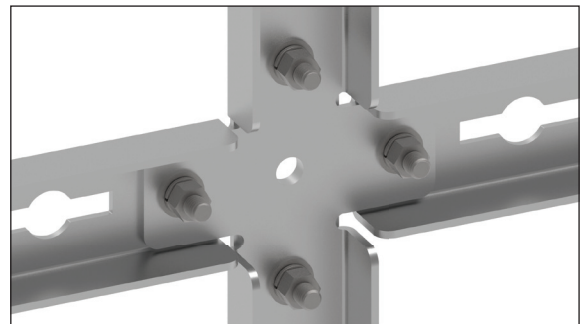

Step #2 Mount the storage bracket assembly to the pole using either bolts or banding.

Bolting Applications

For bolting applications, install two 5/8" through bolts or double arming bolts (not supplied) through the pole 25-3/8" apart. Leave 2" of the through bolts or double arming bolts out of the pole and insert the bolts through the keyholes of the bracket. Secure the bracket with 5/8" nuts (not supplied).

Storage Bracket Mounted to Pole with Bolts

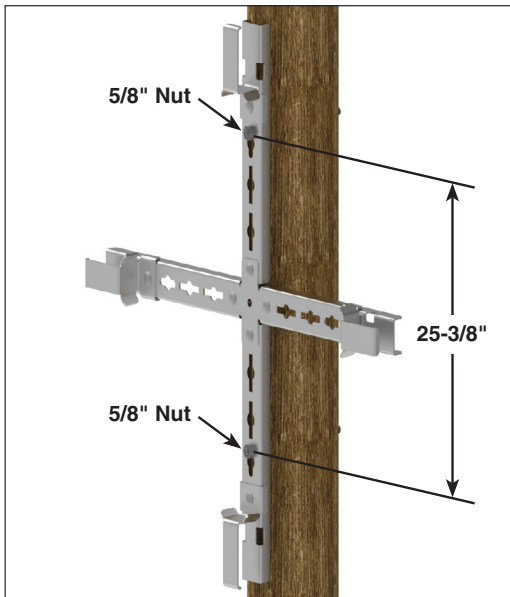

Banding Applications

For banding applications, secure the bracket assembly to the pole by sliding the banding (not supplied) through the banding slots of the bracket and tighten the banding. Banding can be no wider than 1.25".

Storage Bracket Mounted to Pole with Banding

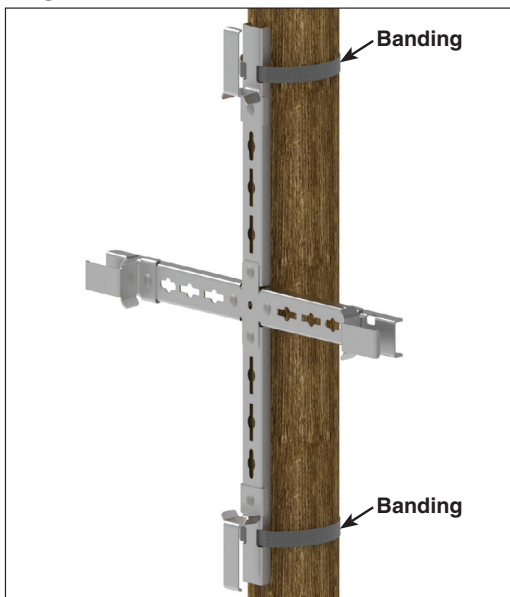

COYOTE® DTC4/6/8 Mounting Bracket Installation

Step #3 Pre-install a carriage bolt with a washer, lock washer, and a nut at both of the large keyhole locations of the COYOTE DTC4/6/8 mounting bracket as shown below. Make sure that the head of the carriage bolt is located on the backside of the bracket.

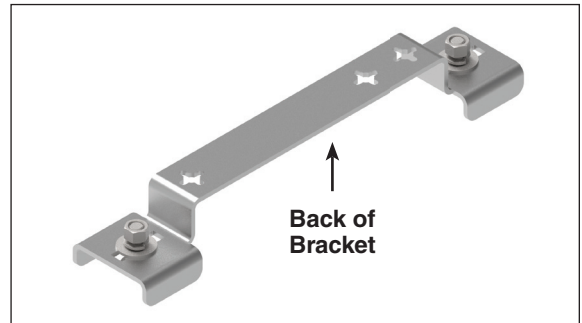

Step #4 Insert the head of each carriage bolt through the keyholes of the storage bracket and slide the carriage bolt into the slot. Secure the mounting bracket to the storage bracket by tightening the nut until the lock washer is flat.

Vertical Mounting Applications

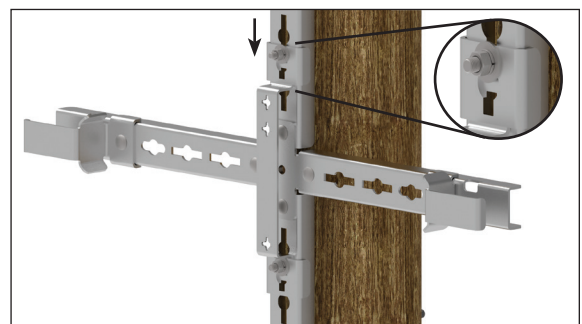

Step #4 Continued

Horizontal Mounting Applications

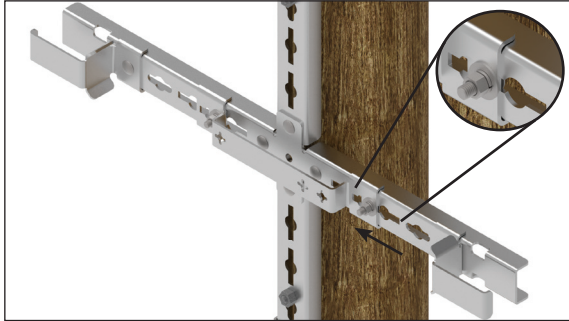
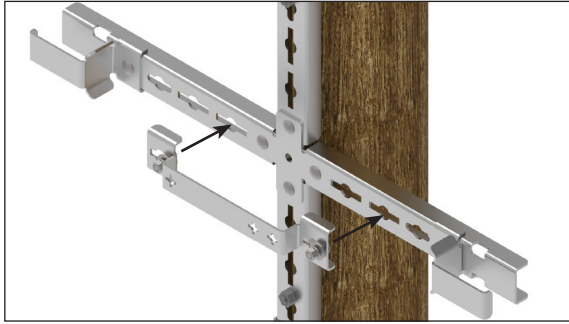

NOTE: For horizontal applications, slide the carriage bolt to the left side of the keyhole to center the bracket.

Step #5 Install the self-tapping bolts at the boss locations on the bottom of the closure base as shown below. Leave an 1/8" (3 mm) gap between the head of the bolt and the base.

DTC4/6

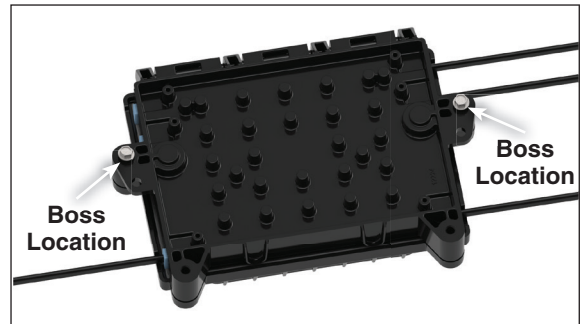

DTC8

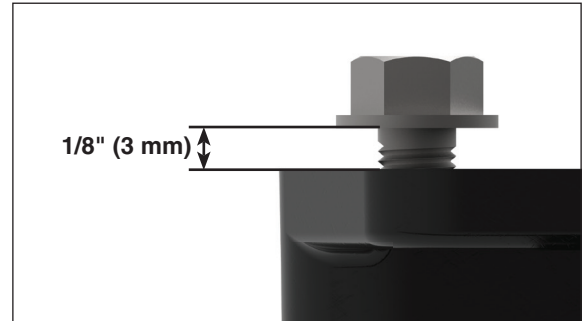
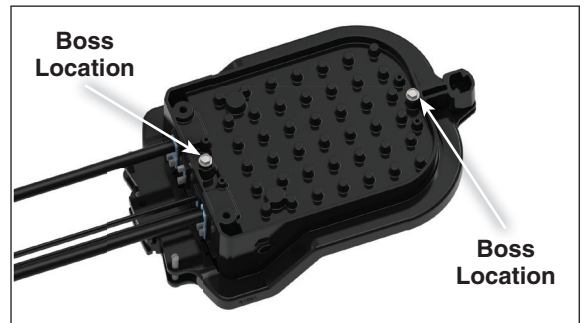

Step #6 Position the heads of the self-tapping bolts in the keyholes of the mounting bracket and slide the bolts into the slots of the keyholes. If the closure seems loose on the mounting bracket, tighten the self-tapping bolts with an open ended or ratchet wrench.

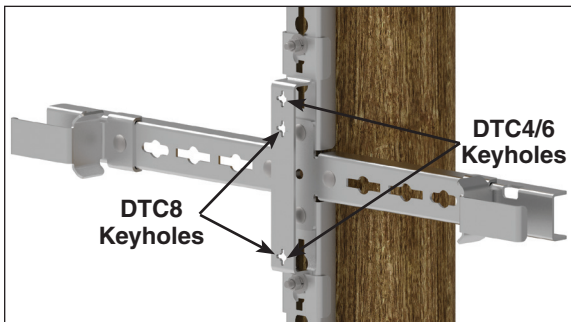

PIP Tip Mount the DTC4/6 in the horizontal position and the DTC8 in the vertical position as shown below.

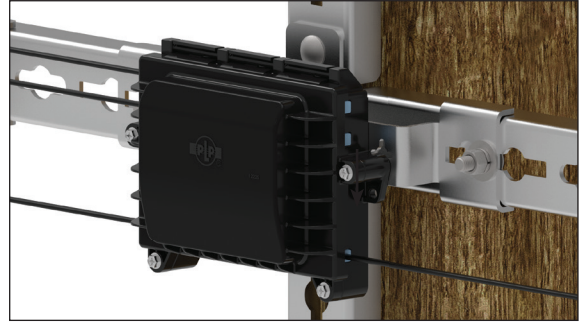

SAFETY CONSIDERATIONS

This application procedure is not intended to supersede any company construction or safety standards. This procedure is offered only to illustrate safe application for the individual.

FAILURE TO FOLLOW THESE PROCEDURES MAY RESULT IN PERSONAL INJURY OR DEATH.

Do not modify this product under any circumstances.

This product is intended for use by trained technicians only. **This product should not be used by anyone who is not familiar with, and not trained to use it.**

When working in the area of energized lines, extra care should be taken to prevent accidental electrical contact. Be sure to wear proper safety equipment per your company protocol.

For proper performance and personal safety, be sure to select the proper size PREFORMED™ product before application.

PREFORMED products are precision devices. To ensure proper performance, they should be stored in cartons under-cover and handled carefully.



PREFORMED LINE PRODUCTS

P.O. Box 91129, Cleveland, Ohio 44101 • 440.461.5200 • preformed.com • email: inquiries@preformed.com