

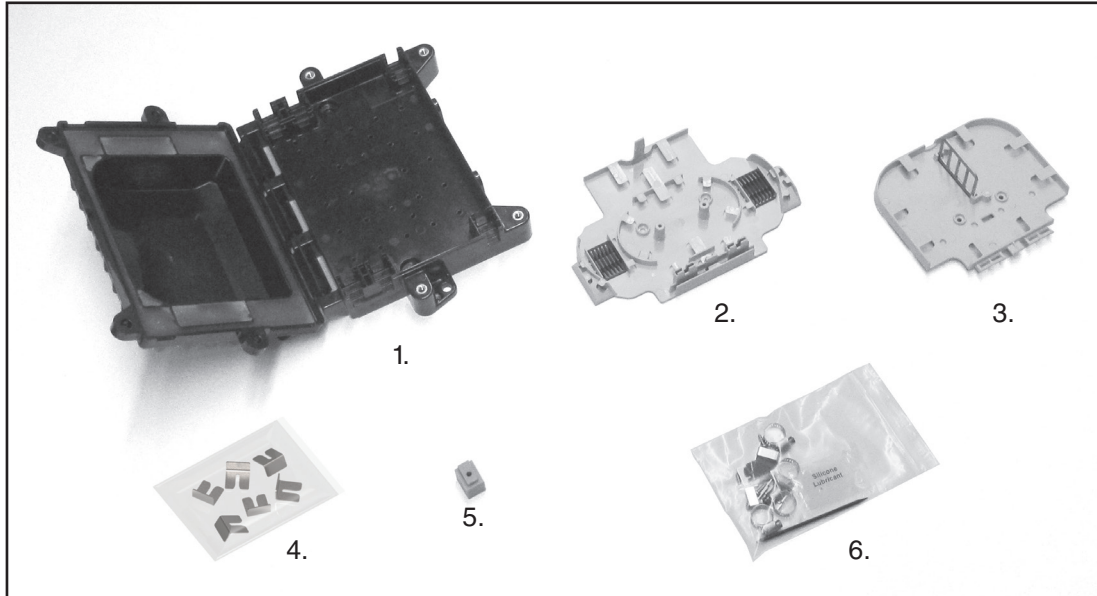

COYOTE® DTC6 (Drop Termination Closure)

Be sure to read and completely understand this procedure before applying product. Be sure to select the proper PREFORMED™ product before application.



NOMENCLATURE

- | | |
|---|---|
| 1. Base with Cover (1) | 4. Flat Drop Cable Retention Clip Kit (1) |
| 2. Splice Organizer (1) | 5. Small Grommets (6) |
| 3. Bulkhead Tray (with Splice and Adapters Organizer) (1) | 6. Small Parts Bag (1) |

TOOLS REQUIRED

- 3/8" & 7/16" socket or can wrench
- Fiber optic cable opening tools
- 1/4" Nut driver or screwdriver
- Phillips Head Screwdriver
- Snips

| COYOTE® DTC 4/6 Mounting Bracket Kits | | |
|---------------------------------------|--|-----------|
| Catalog Number | Description | Kit Image |
| 8004109 | COYOTE DTC 4/6 Pole/Wall Mount Bracket Kit | |
| 8004110 | COYOTE DTC 4/6 Cable Storage Bracket Kit | |
| 8004111 | COYOTE DTC 4/6 Aerial Mounting Bracket Kit – Strand Applications | |
| 8004112 | COYOTE DTC 4/6 Aerial Mounting Bracket Kit – ADSS Applications | |

General Base Preparation

Step #1 Install the fiber organizer into the base with the self-tapping screws provided.

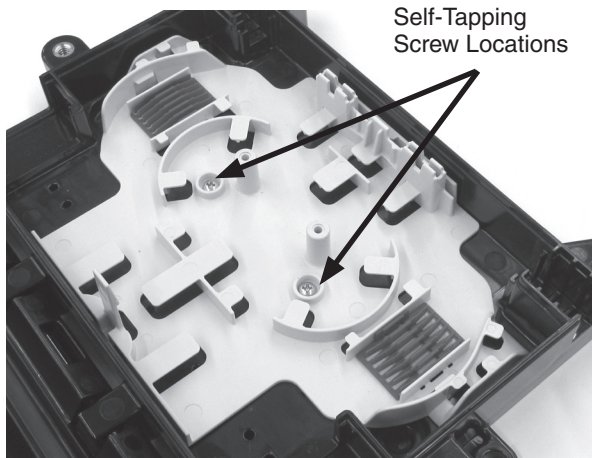

Step #2 Determine the cable entry locations for butt applications as shown below.

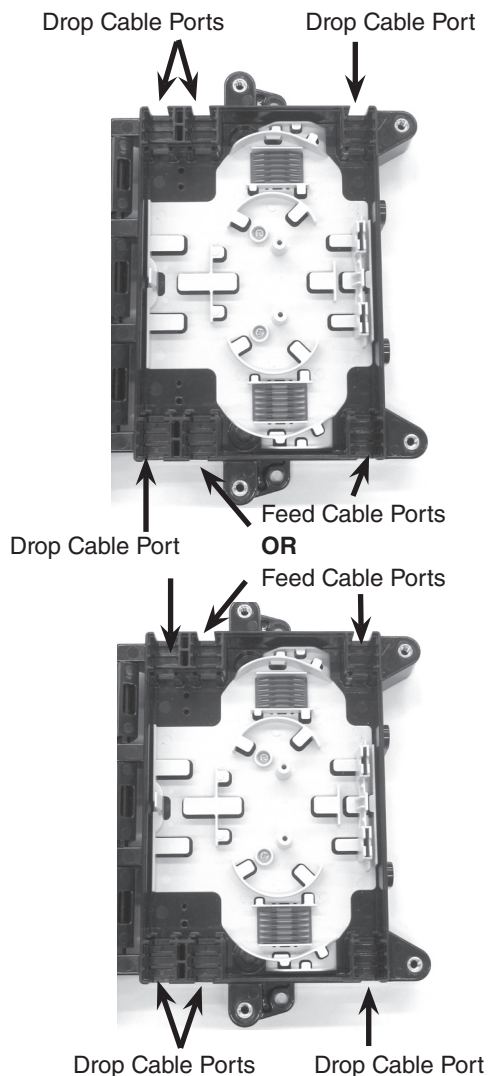

Step #3 Determine the cable entry locations for in-line applications as shown below.

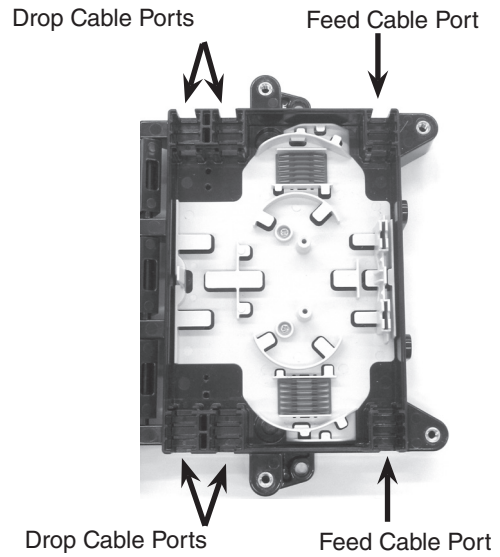

Step #4 Install the plug(s) in any grommet that will not be used and lubricate all four sides of the grommet with silicone lubricant.

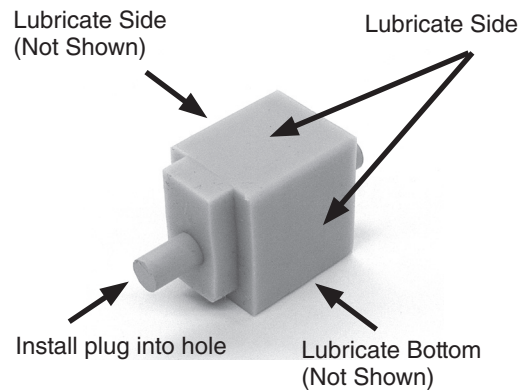

Step #5 Insert the grommet(s) with the plug(s) in any cable port(s) that will not be used.

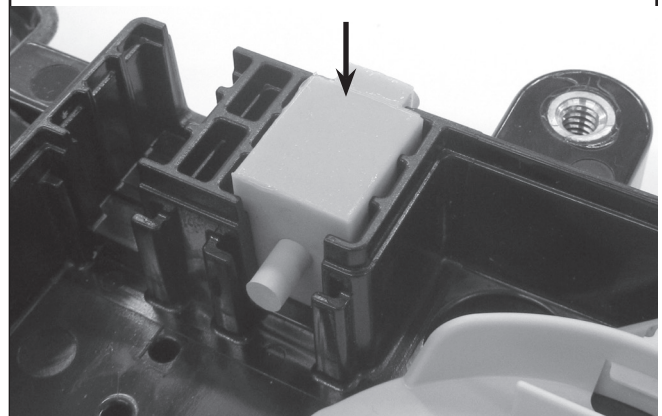

General Base Preparation

Step #6 Measure each cable to determine the diameter of the cable and select the proper grommet(s) for your application.

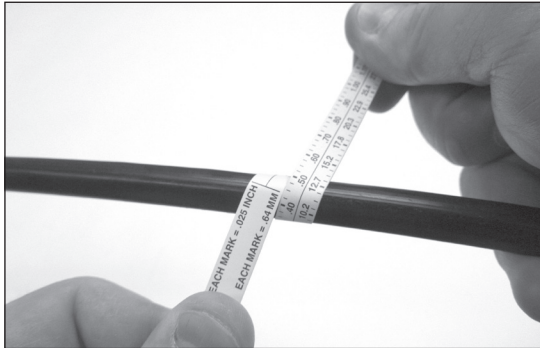

NOTE: The lines on each grommet represent the slit locations for cables expressing fiber or pre-connectorized drop cables.

| | Small Grommets | Cable Diameter Range |
|---|----------------|---|
| A | | SOLID / PLUG |
| B | | .170" - .250" (4.3 - 6.4 mm) ROUND CABLES |
| C | | .250" - .350" (6.4 - 8.9 mm) ROUND CABLES |
| D | | .156" - .170" (4.0 - 4.3 mm) ROUND CABLES |
| E | | .093" - .125" (2.4 - 3.2 mm) ROUND CABLES |
| F | | FLAT DROP CABLES |
| G | | .350" - .420" (8.9 - 10.7 mm) ROUND CABLES |

Step #7 Insert each cut cable in the appropriate grommet. If the cable is expressing fiber, slit the grommets as shown below, before installing the grommets over the cable. (See Step 6 for slit locations on each grommet).

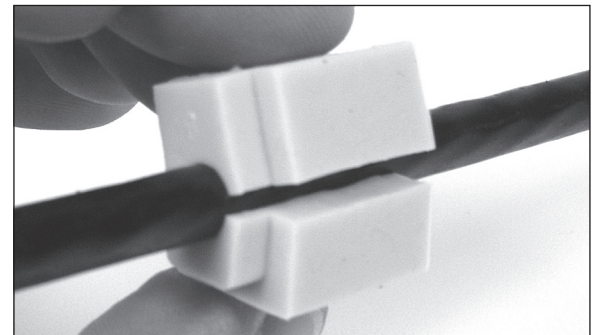
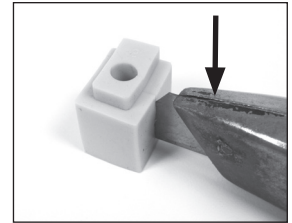
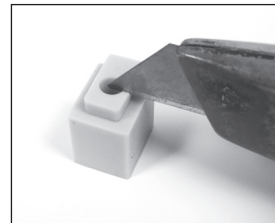
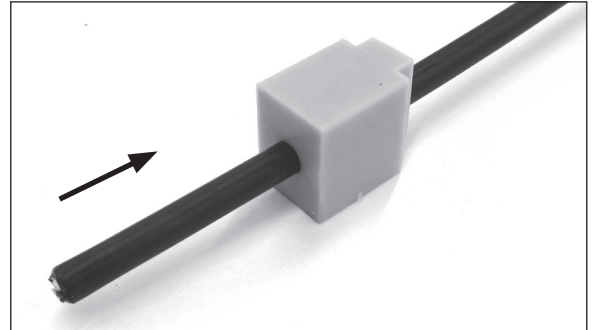

Step #8 If the cable is a Figure 8 style cable or has a tracer wire, remove the ground wire or tracer wire from the portion of the cable that will be positioned in the grommet and insert the cable into the grommet.

Cable with Tracer Wire

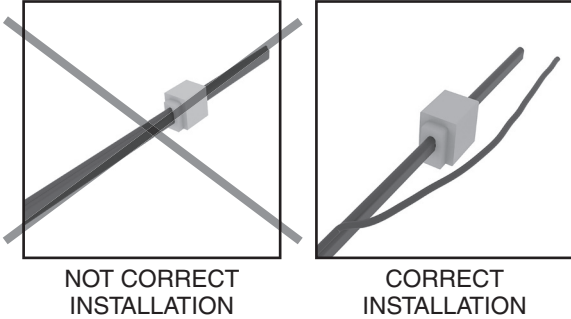
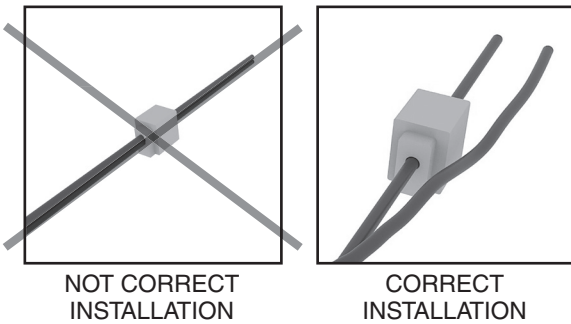
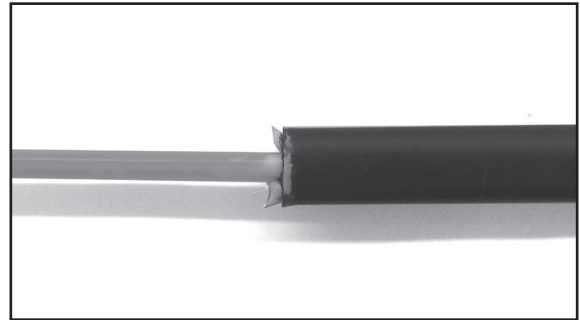

Figure 8 Style Cable



Preparation and Installation of the Round Drop Cable

Step #11 Trim the strength members flush with the sheath opening.



Step #12 Mark and remove the buffer tube 1/8" (.32 cm) away from the sheath opening.

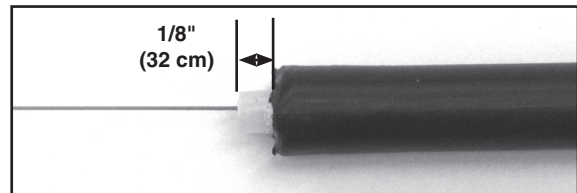

Step #9 Measure, mark and remove the cable sheath for cut cable applications, as shown below.

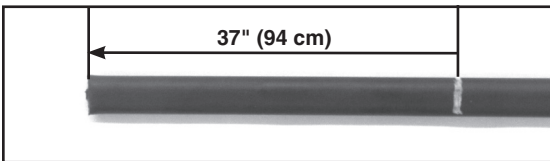

Step #10 Measure, mark and remove the cable sheath for expressed fiber applications, as shown below.

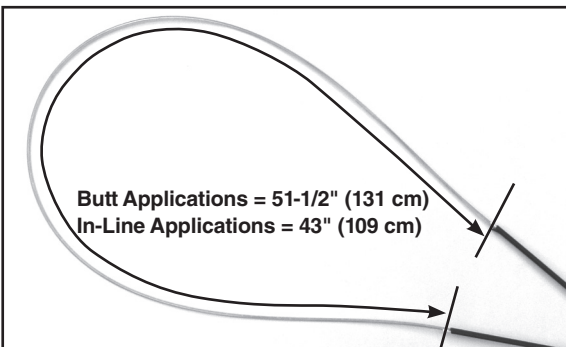

Step #13 Adjust each grommet as shown below.

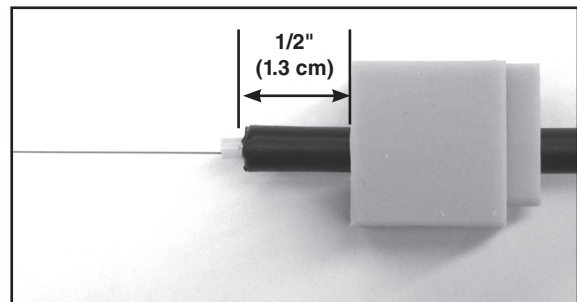

Step #14 If the cable contains Kevlar®, braid the Kevlar.

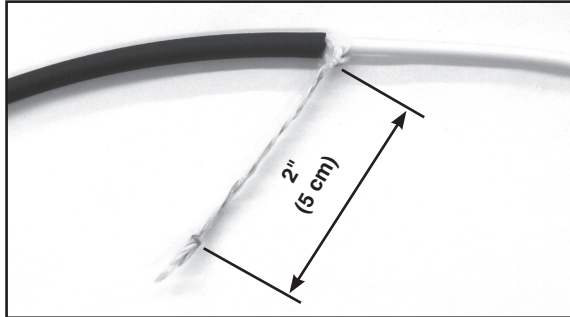

NOTE: If the cable contains Kevlar but is the feed cable, then follow Steps 17 and 18.

Step #15 Lubricate the grommet (Step #4) and place it into the pocket of the base.

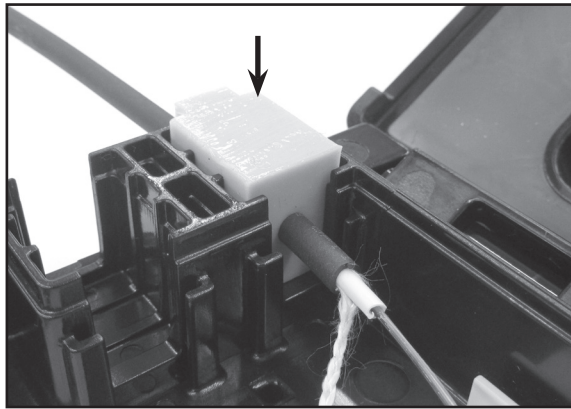

Step #16 For drop cables with Kevlar, place a screw in the hole next to the grommet pocket. Wrap the braided Kevlar around the screw and tighten the screw.

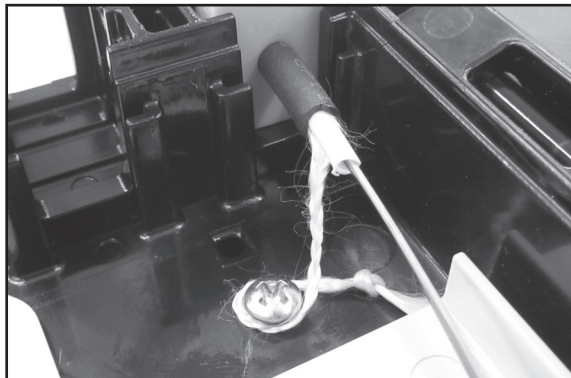

Step #17 If the cable does not contain Kevlar or contains Kevlar but is the feed cable, align the end of the hose clamp clip with the cable sheath opening and secure it with the micro hose clamp. Make sure that the head of the hose clamp is seated on top of the cable as shown below.

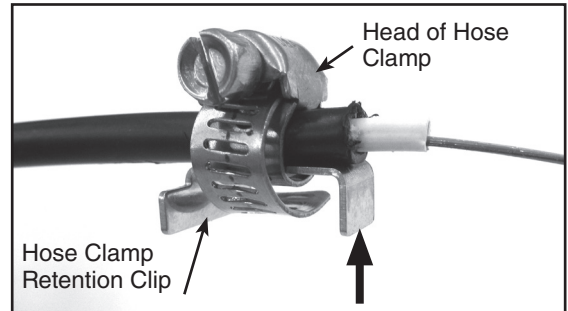

Step #18 Insert the back of the hose clamp clip in the retention clip slot of the base while inserting the grommet into the grommet pocket. Make sure that the grommet has been lubricated before inserting it into the grommet pocket (Step #4).

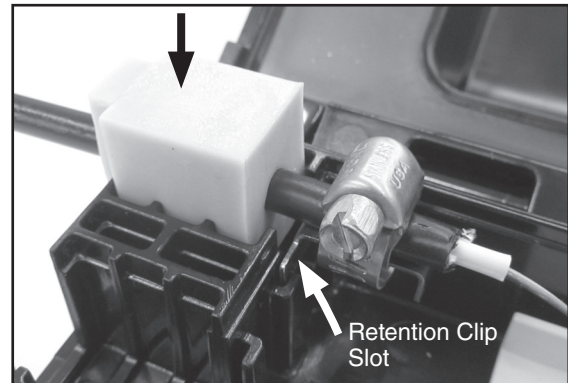

Preparation and Installation of the Flat Drop Cables

Step #19 Trim the cable strength members as close to the cable sheath opening as possible.

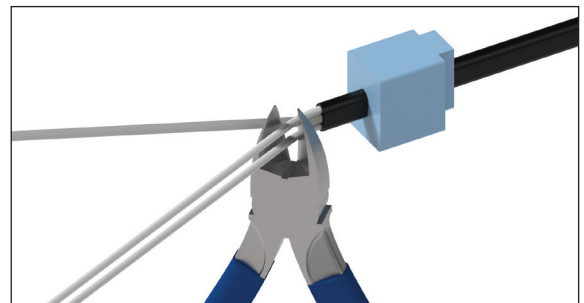

Step #20 Remove the buffer tube roughly 1/2" (1.3 cm) from the cable sheath opening.

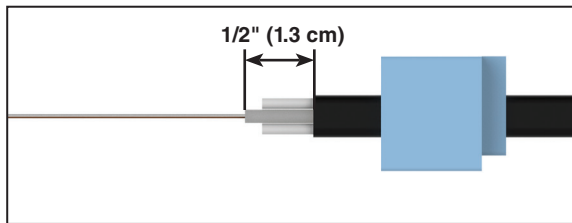

Step #21 Lubricate all four outer surfaces of the grommet. Once the lubricant has been applied, smear it to provide a light coating on each surface.

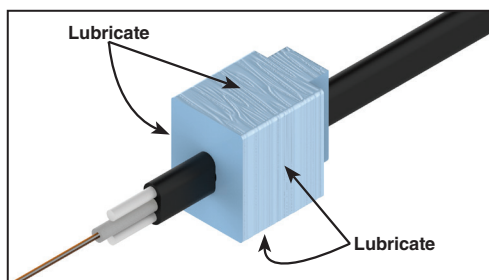

Step #22 Insert the grommet into the grommet pocket of the base.

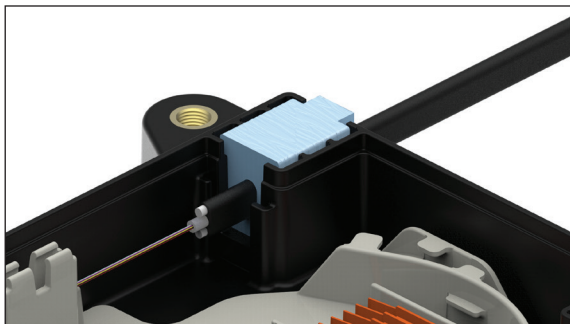
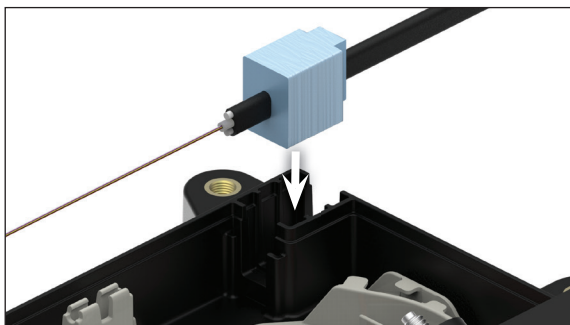

Step #23 Insert the cable retention clip into the retention clip pocket and push the clip onto the cable.

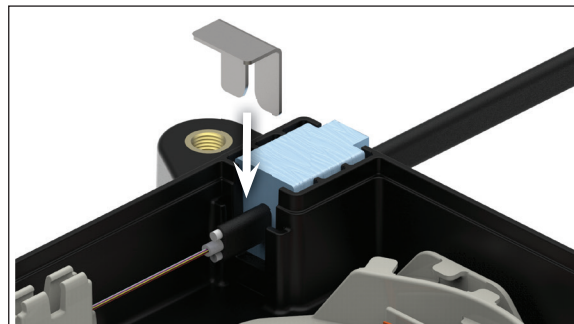

PLP Tip: Use a can wrench to push the cable retention clip down into the slot.

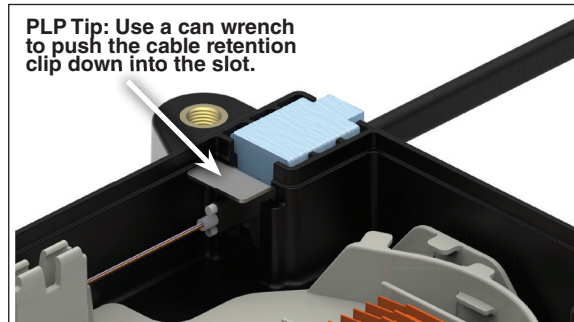

Preparation for Figure 8 Drop Cable or Drop Cable with Tracer Wire

Step #24 Peel back the tracer wire or ground wire from the cable.

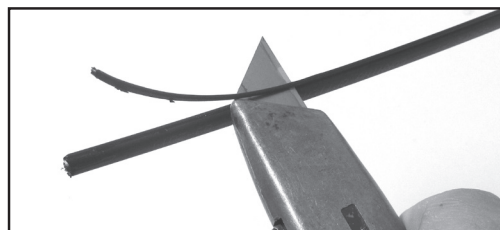

Step #25 Shave the rough edges of the cable where the tracer wire or ground wire was removed in the area where the grommet will be located.

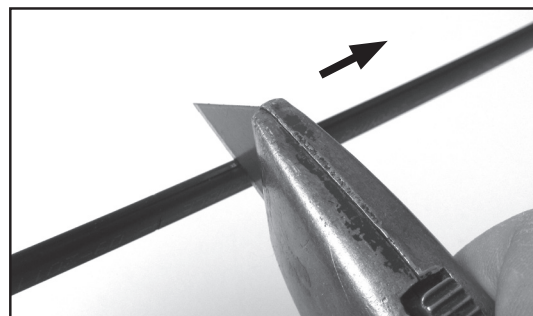

Step #26 Insert the cable through the grommet while leaving the tracer wire or ground wire to the side.

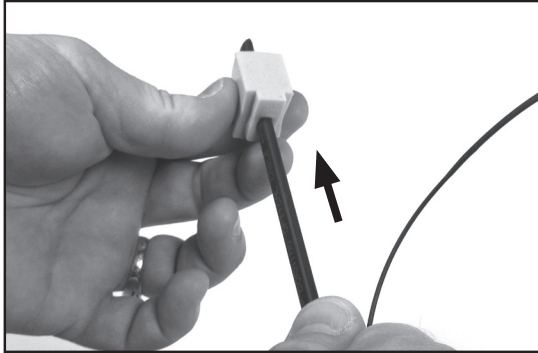

Step #27 Install the cable into the closure while leaving the tracer wire or ground wire on the outside of the closure.

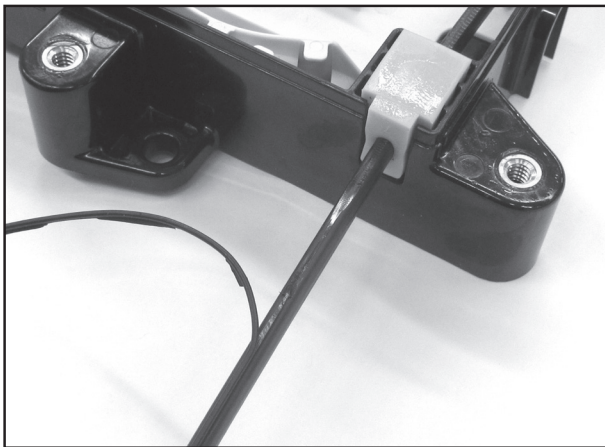

Step #28 If the cables have tracer wires, connect the 2 tracer wires using a Scotchlok™ Connector (not included).



Routing for Butt Splice Applications

Step #29 Route expressed fibers as shown.

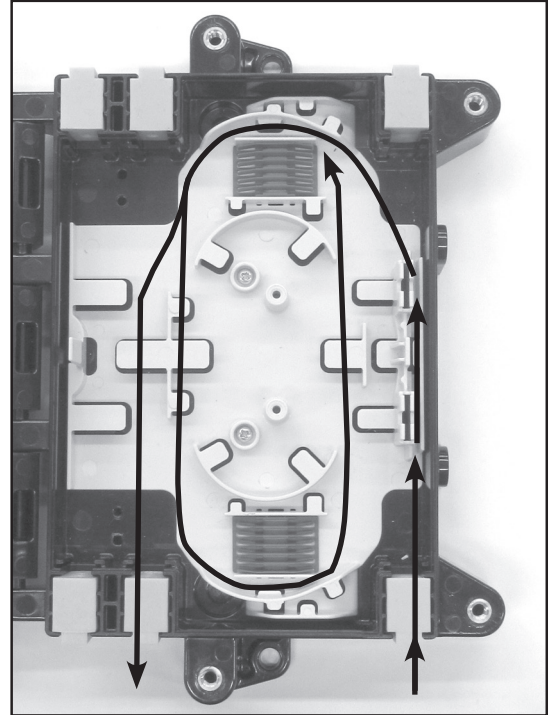

Routing for In-Line Splice Applications

Step #30 Route expressed fibers as shown below.

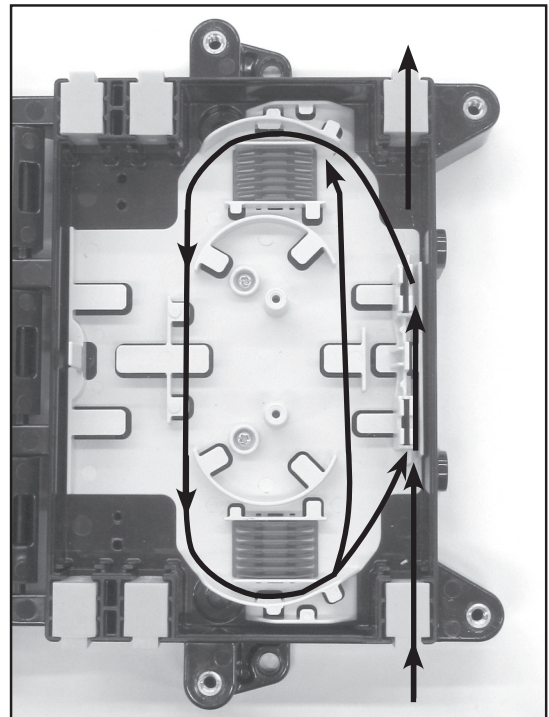

Step #31 Route and splice fibers per your accepted company practice.

Cross-Connect Applications

Step #32 Route the **incoming** and the outgoing fibers to the side of the splice block facing the two cable ports per your accepted company practice.

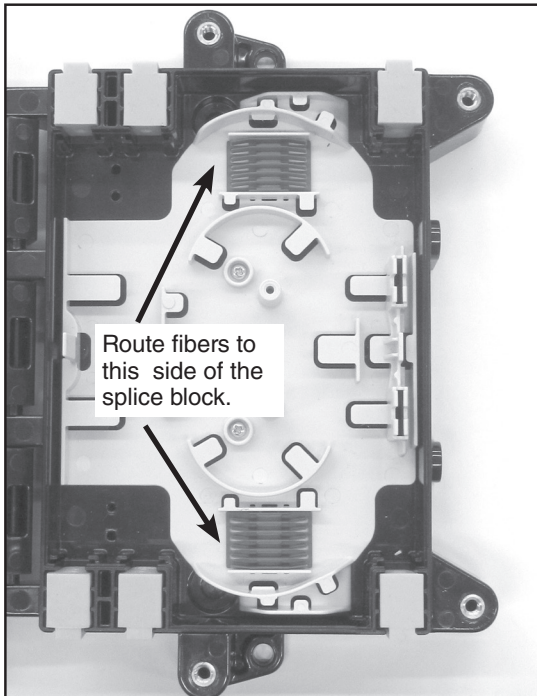

Step #33 Install the hinge of the bulkhead tray into the fiber organizer as shown below.

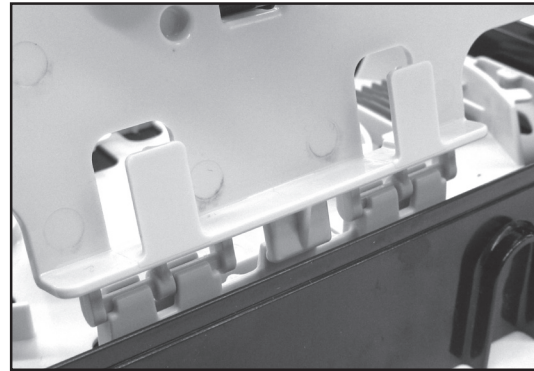
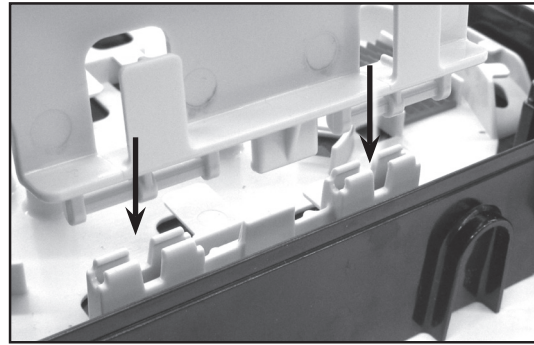

Step #34 Store the fiber pick on the bottom side of the bulkhead tray.

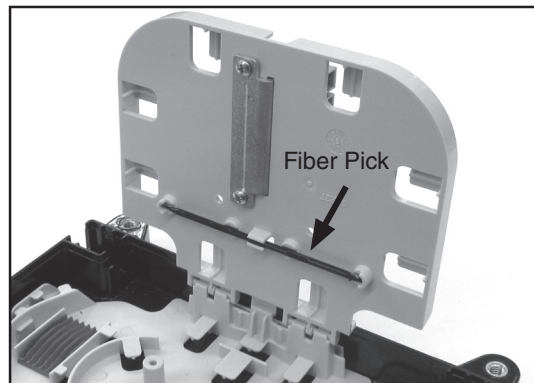

Step #35 Latch the bulkhead tray into place.

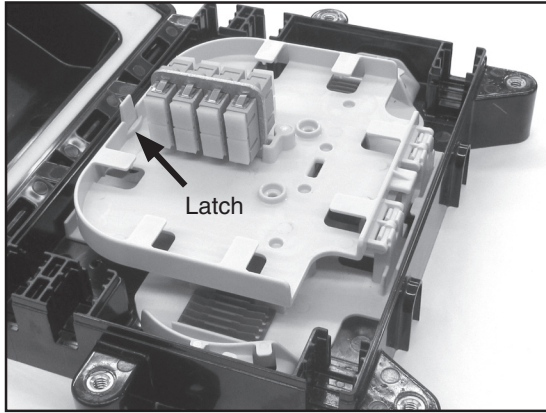

Step #36 Insert the pigtail connectors into the adapters of the bulkhead tray.

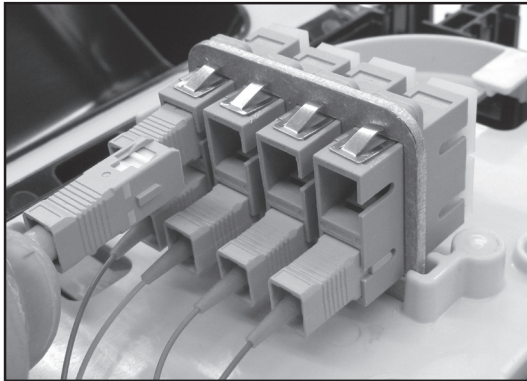

Step #37a Route pigtails for **incoming** fibers as shown below.

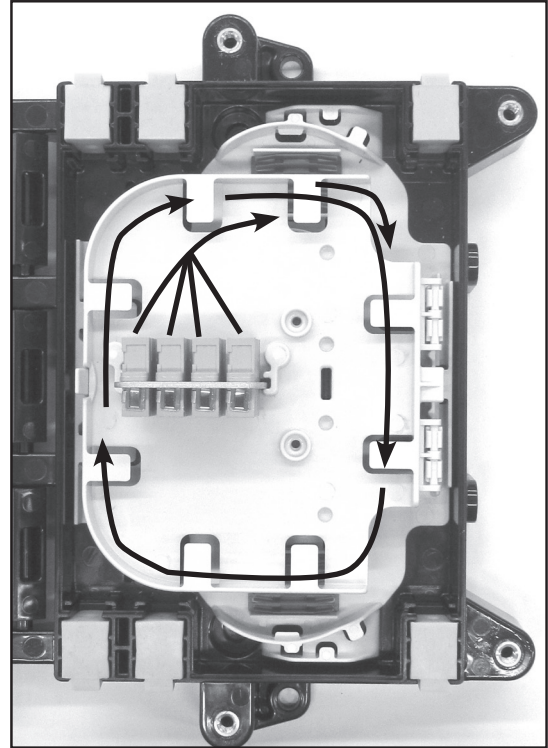

Step #37b Route the pigtails for **incoming** fibers as shown below.

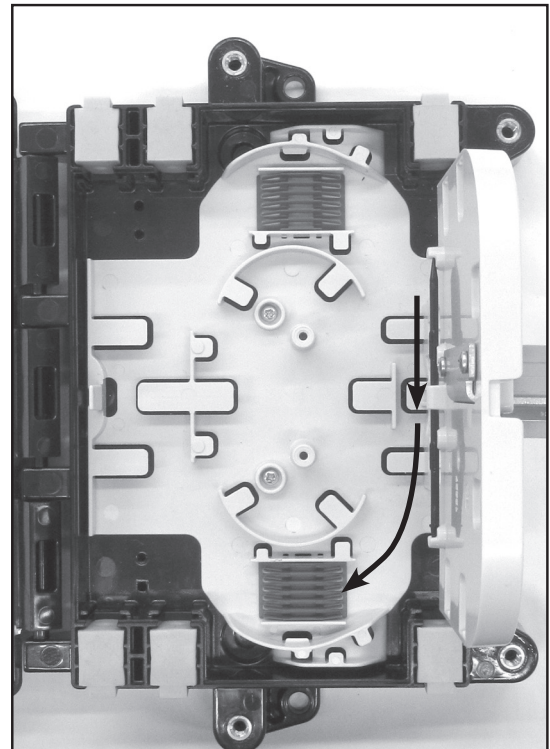

Step #38a Route the pigtails for **outgoing** fibers as shown below.

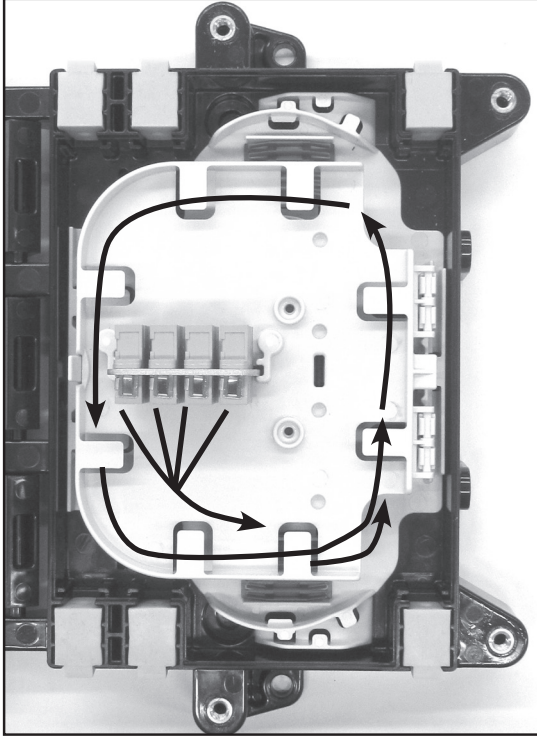

Step #38b Route the pigtails for **incoming** fibers.

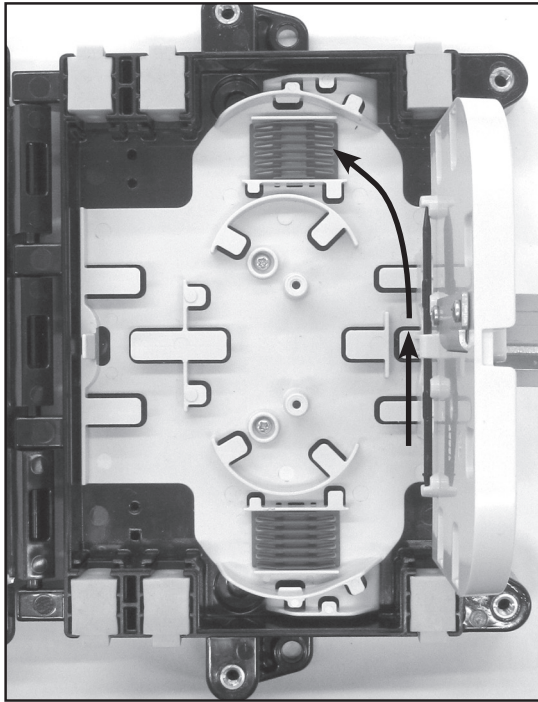

Step #39 Splice the matching fibers and the pigtail fibers (ex.: incoming fiber 1 to incoming pigtail fiber 1) per your accepted company practice.

Cover Installations

Step #40 Close the cover and secure it to the base by hand tightening the 4 hex head bolts.

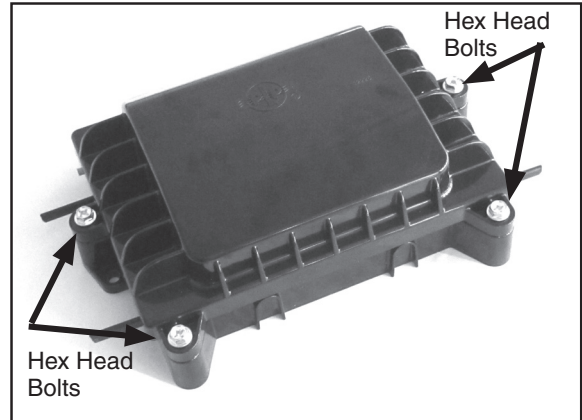

NOTE: Tighten bolts evenly by hand. **DO NOT USE POWER TOOLS TO INSTALL THE COVER.**

NOTE: When using a can wrench or a nut driver, the installed torque is 35 to 40 in. lbs.

Mounting Options

Step #41 Pole/ Wall Mounting shown below.

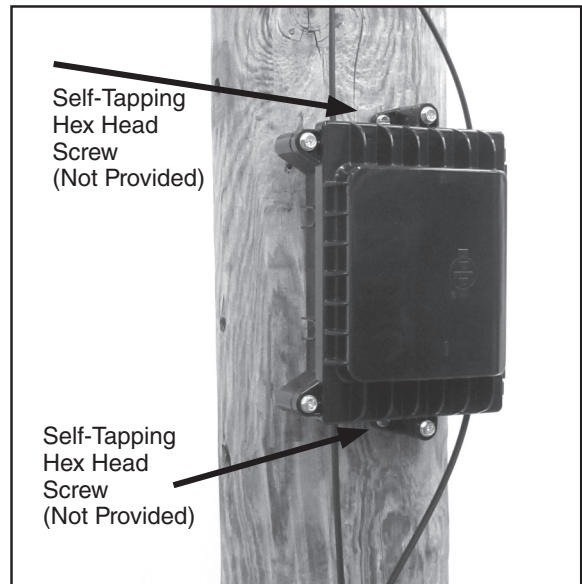

Self-Tapping
Hex Head
Screw
(Not Provided)

Self-Tapping
Hex Head
Screw
(Not Provided)

SAFETY CONSIDERATIONS

This application procedure is not intended to supersede any company construction or safety standards. This procedure is offered only to illustrate safe application for the individual.

FAILURE TO FOLLOW THESE PROCEDURES MAY RESULT IN PERSONAL INJURY OR DEATH.

Do not modify this product under any circumstances.

This product is intended for use by trained technicians only. **This product should not be used by anyone who is not familiar with, and not trained to use it.**

When working in the area of energized lines, extra care should be taken to prevent accidental electrical contact. Be sure to wear proper safety equipment per your company protocol.

For proper performance and personal safety, be sure to select the proper size PREFORMED™ product before application.

PREFORMED products are precision devices. To ensure proper performance, they should be stored in cartons under cover and handled carefully.



PREFORMED LINE PRODUCTS

P.O. Box 91129, Cleveland, Ohio 44101 • 440.461.5200 • preformed.com • email: inquiries@preformed.com

SP3271-2