

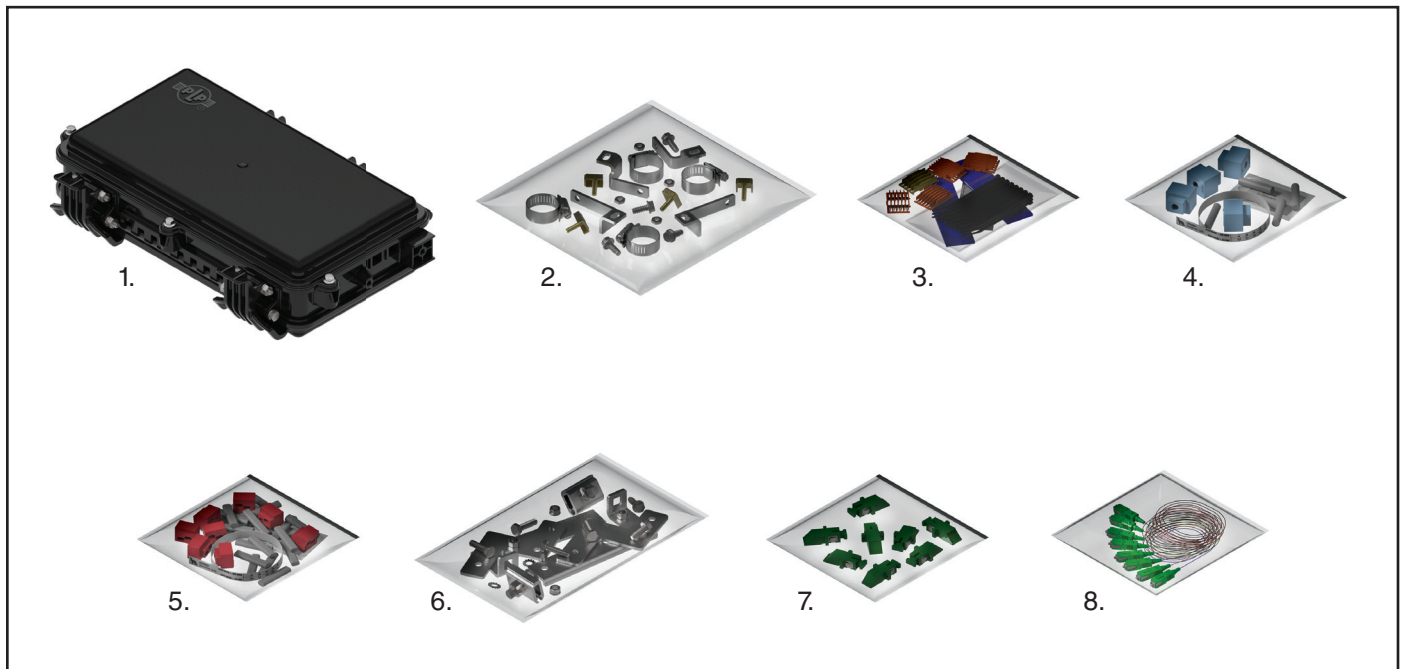

COYOTE® (ATC) Aerial Terminal Closure

Be sure to read and completely understand this procedure before applying product. Be sure to select the proper PREFORMED™ product before application.



NOMENCLATURE

1. COYOTE® ATC Closure (1)
2. Strength Member Bracket Kit (1)
3. Splice Block Kit (1)
4. Feed Grommet Kit - Includes 4 Grommets (1)
5. Drop Grommet Kit - Includes 8 Grommets (1)
6. Aerial Hanger Bracket Kit for Strand Applications (1)
7. Adapter Kit (1) - OPTIONAL ITEM
8. Pigtail Kit (1) - OPTIONAL ITEM

TOOLS REQUIRED:

- 3/8" and 7/16" can wrench or socket
- Fiber optic cable opening tools
- 1/4" nut driver
- Snips

Feed Chamber Preparation

Feed & Branch Cable

Step #1 Measure each cable to determine the diameter of the cable and select the proper grommet(s) for your application.

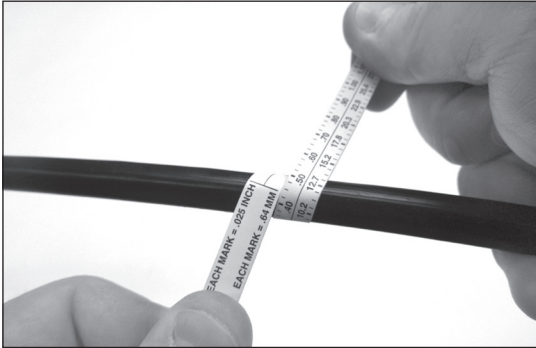

Large Grommet Selection		Cable Diameter Range
A		SOLID / PLUG
B		.200" - .250" (5.0 - 6.4 mm) ROUND CABLES
C		.250" - .300" (6.4 - 7.6 mm) ROUND CABLES
D		.300" - .350" (7.6 mm - 9.0 mm) ROUND CABLES
E		.350" - .400" (9.0 - 10.2 mm) ROUND CABLES
F		.400" - .450" (10.2 - 11.4 mm) ROUND CABLES
G		.450" - .500" (11.4 - 12.7 mm) ROUND CABLES
H		.500" - .550" (12.7 - 14.0 mm) ROUND CABLES
J		.156" - .187" (4.0 mm - 4.7 mm) ROUND CABLES

Step #2 Install grommet(s) on cable. If the cable is cut, insert the cable through the grommet. If the cable is to be expressed, the grommets will need to be slit. To slit each grommet, position a utility knife with the cutting edge against the top surface as shown below and cut through the grommet.

Cut Cables

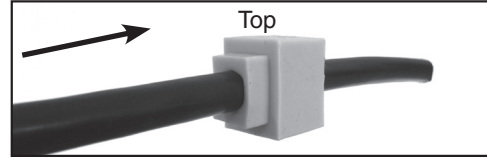

Expressed Cables

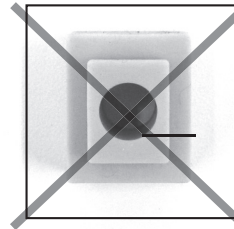
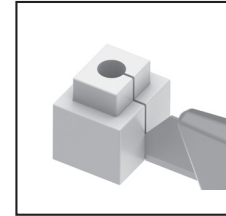
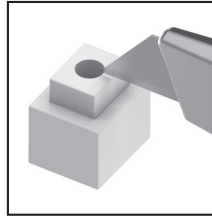

NOT CORRECT
SLITTING ANGLE

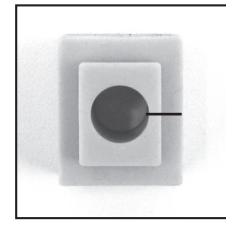

CORRECT SLITTING
ANGLE

Step #3 If the cable is a figure 8 style cable or has a tracer wire, remove the ground wire or tracer wire from the portion of the cable that will be positioned in the grommet and insert the cable into the grommet.

Cable with Tracer Wire

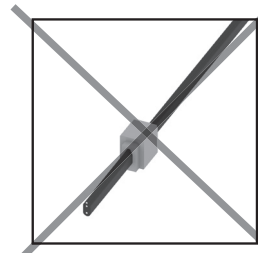

NOT CORRECT
INSTALLATION

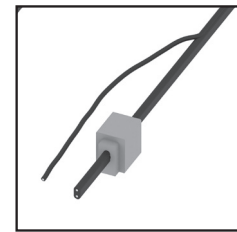

CORRECT
INSTALLATION

Figure 8 Style Cable

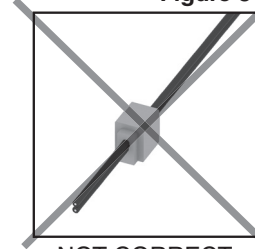

NOT CORRECT
INSTALLATION

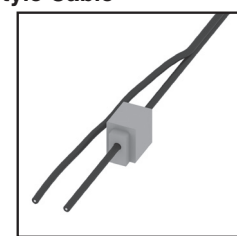

CORRECT
INSTALLATION

Step #4 Prepare the loose tube/buffer tube cable(s) for cut applications

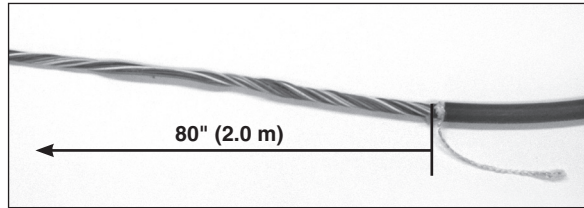

Sheath Opening Breakdown for Feed and Branch Cable

Buffer Tube Length	35" (.89 m)
Bare Fiber Length	45" (1.1 m)
Total Sheath	80" (2.0 m)

PLP Tip: Leave about 5" (13 cm) of strength member to trim later.

Cable Sheath Opening for Applications Where Fiber is Dedicated to the Splice Point

Step #5a Prepare the loose tube/buffer tube cable(s) for mid sheath applications (Express/Balloon/Ring Cut).

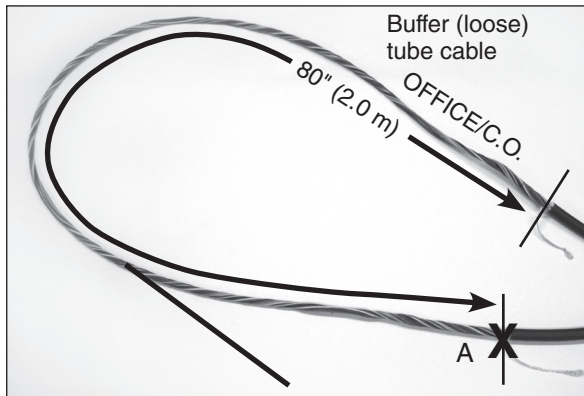

For Applications Where Fiber is Dedicated to the Splice Point

Buffer Tube Length	35" (.89 m)
Bare Fiber Length	45" (1.1 m)
Total Sheath Opening	80" (2.0 m)
Fiber/Buffer Tube Cut	A (see image)

PLP Tip: Leave about 5" (13 cm) of strength member to trim later.

Cable Sheath Opening for Applications Where Fiber is NOT Dedicated to the Splice Point

Step #5b Prepare the loose tube/buffer tube cable(s) for mid sheath applications (Express/Balloon/Ring Cut).

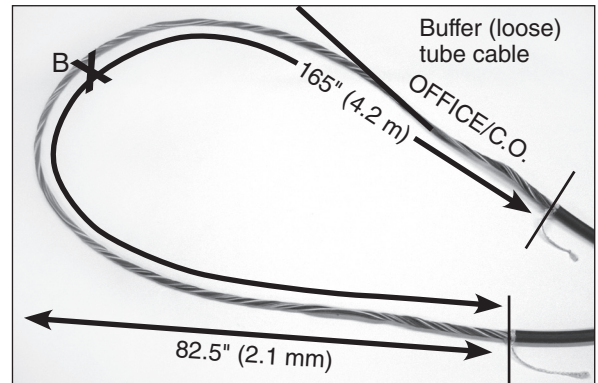

For Applications Where Fiber is NOT Dedicated to the Splice Point

Buffer Tube Length per Side of Cut	35" (.89 m)
Bare Fiber Length per Side of Cut	47.5" (1.2 m)
Total Length per Side of Cut	82.5" (2.1 m)
Total Sheath Opening	165" (4.2 m)
Fiber/Buffer Tube Cut	B (see image)

PLP Tip: Leave about 5" (13 cm) of strength member to trim later.

Cable Sheath Opening for Applications Where Fiber is Expressed Through the Buffer Tube

Step #5c Prepare the loose tube/buffer tube cable(s) for expressed fiber (buffer tube window cut) applications.

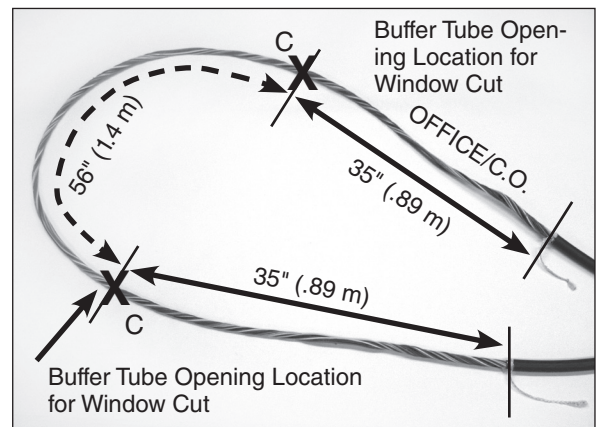

For Applications Where Fiber is Expressed through the Buffer Tube

Buffer Tube Length per Side of Window Cut	35" (.89 m)
Bare Fiber Length	56" (1.4 m)
Total Sheath Opening	126" (3.2 m)
Buffer Tube Opening Location	C (see image above)

PLP Tip: Leave about 5" (13 cm) of strength member to trim later.

Step #6 If the cable contains aramid yarn, braid roughly 3" (7.2 cm) of the yarn.

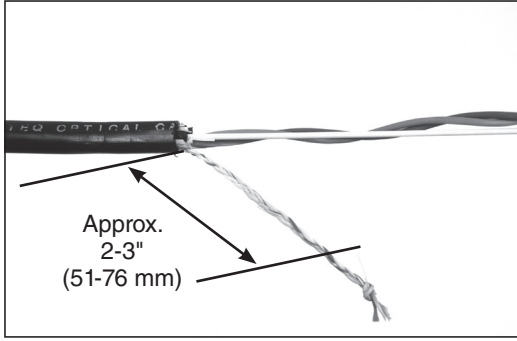

Step #7 Trim cable strength member 1" (2.5 cm) away from the cable sheath opening.

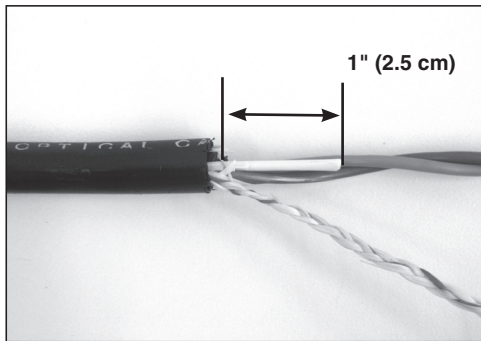

Attaching Cables to Strength Member Brackets

Step #8 Select the correct strength member bracket to attach the cable to.

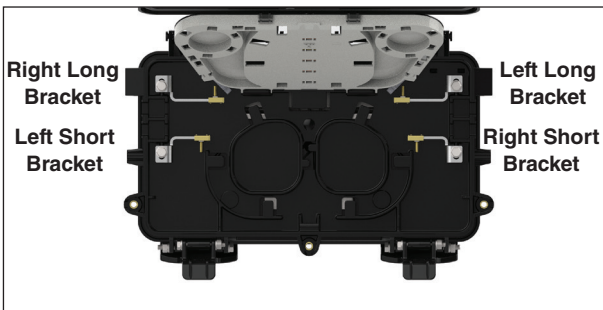

Step #9 Install a cap onto each strength member bracket and secure it with a nut.

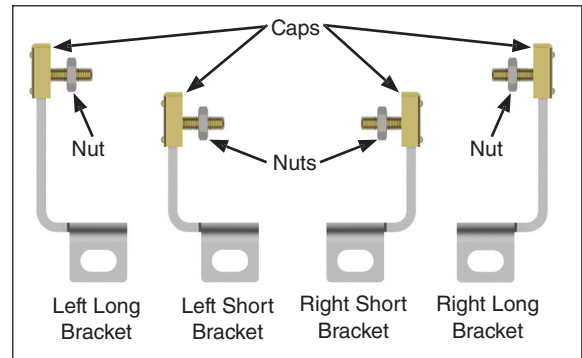

Step #10 Position the strength member under the cap of the strength member bracket.

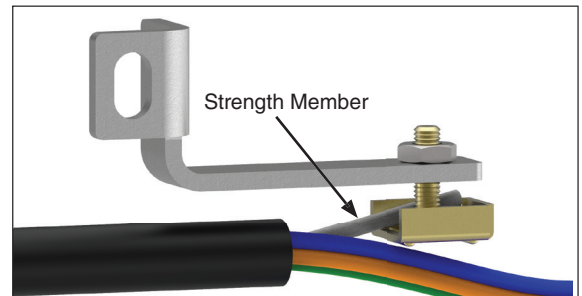

Step #11 If the cable contains aramid yarn, wrap the braided aramid yarn around the stud of the cap as shown below.

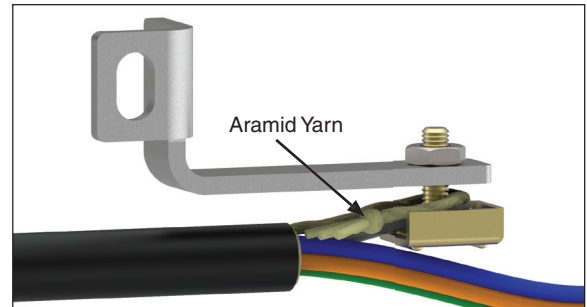

Step #12 Tighten the nut of the cap to secure the strength member and the braided aramid yarn under the cap.

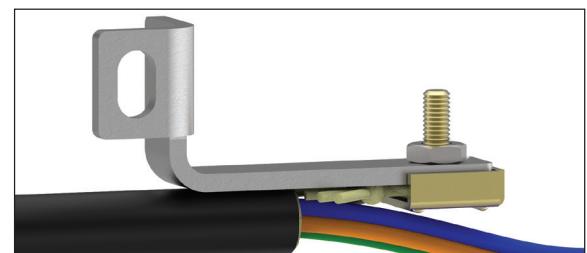

Step #13 Secure the cable to the strength member bracket with a hose clamp.

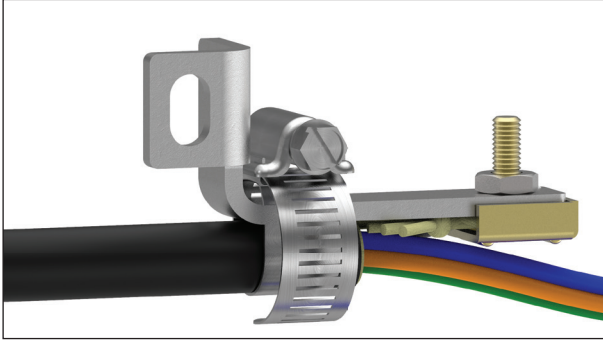

Feed & Branch Cable

Step #14 Lubricate all four outer surfaces of each grommet. Once the lubricant has been applied, smear it to provide an even coating on each surface

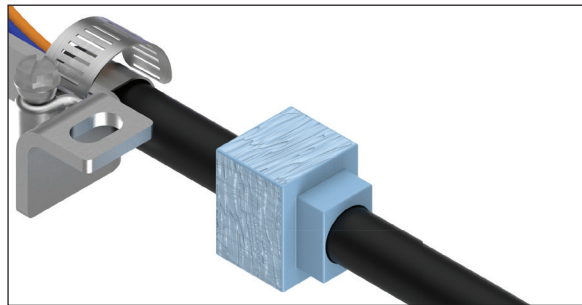
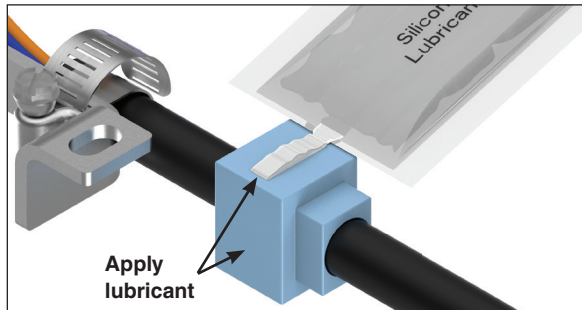

Step #15 If your application requires a cut grommet, apply a layer of lubricant along cut seam as shown below.

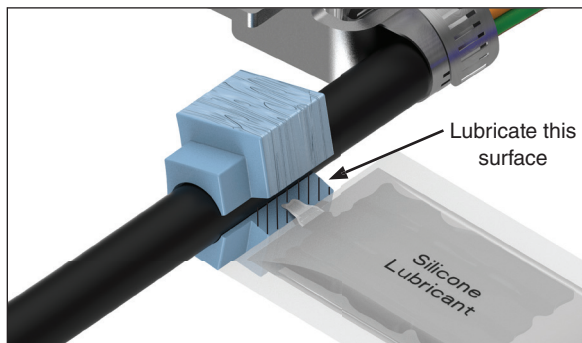

Step #16 Position the grommets in the grommet pockets of the closure as shown below and apply additional lubricant to the top surface of each grommet if removed during the assembly process.

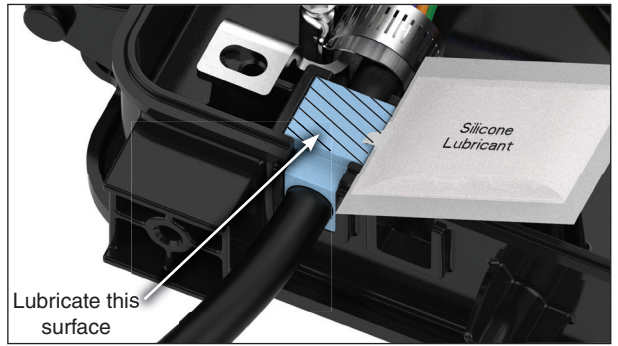

Step #17 Align the hole of each strength member bracket with the hole of the boss next to each grommet pocket.

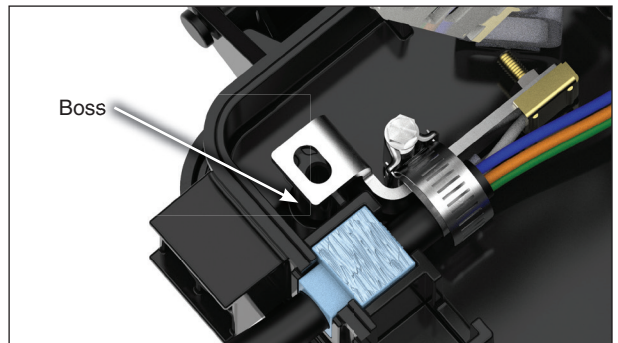

Step #18 Secure each strength member bracket to the closure with a self-tapping bolt.

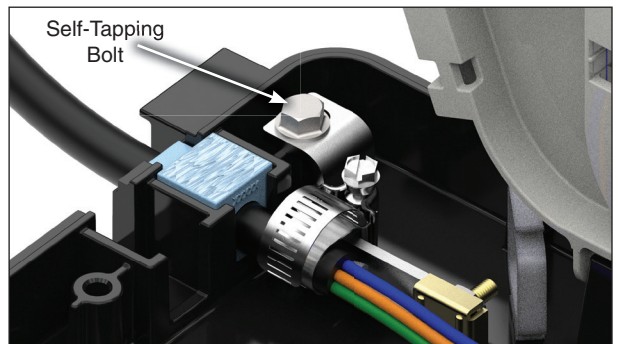

Buffer Tube Routing

Step #19 Route and store expressed buffer tubes under the storage brackets.

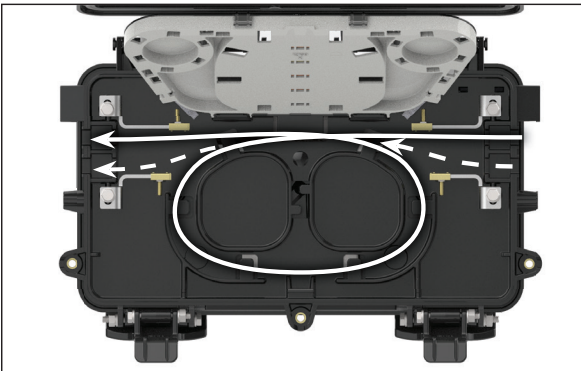
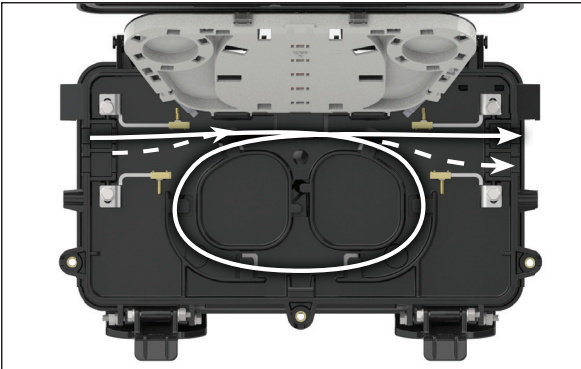

Step #20 Route the buffer tubes containing the fibers to be spliced under the storage brackets and clips to the splice tray. Make sure not to route the buffer tube(s) in the clip closest to where the buffer tube(s) enter the splice tray.

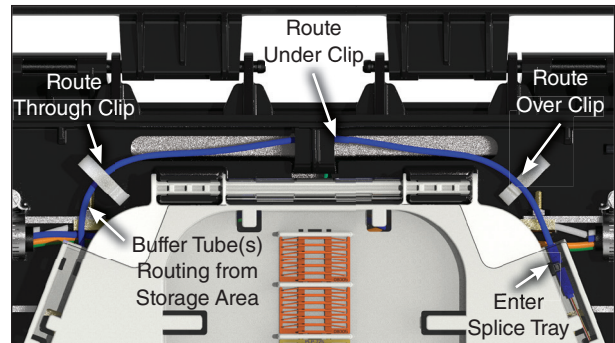
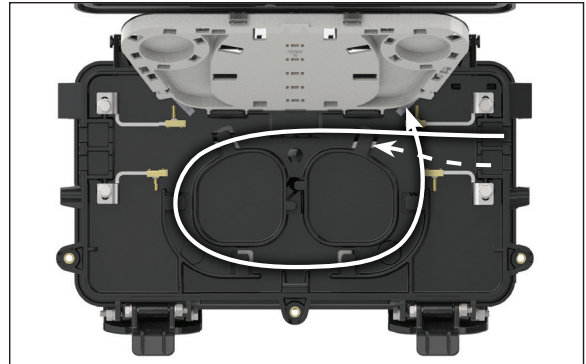
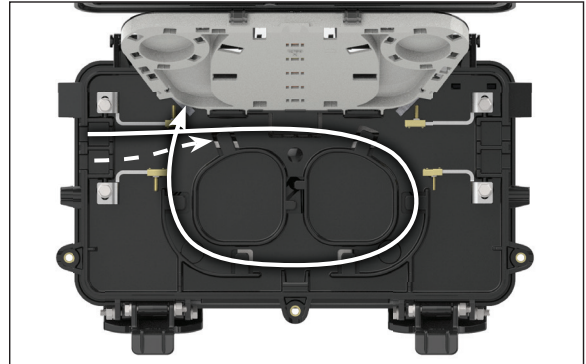

Step #21 Wrap the buffer tube(s) with felt and secure the buffer tube(s) to the splice tray with tie wrap.

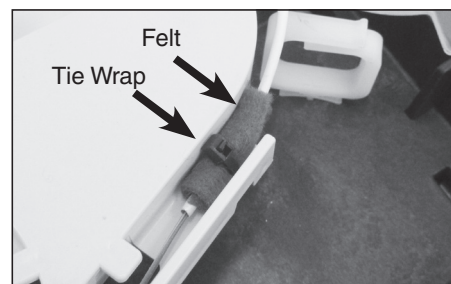

Bulkhead Preparation

Step #22 Remove the shroud from the bulkhead by removing the screws.

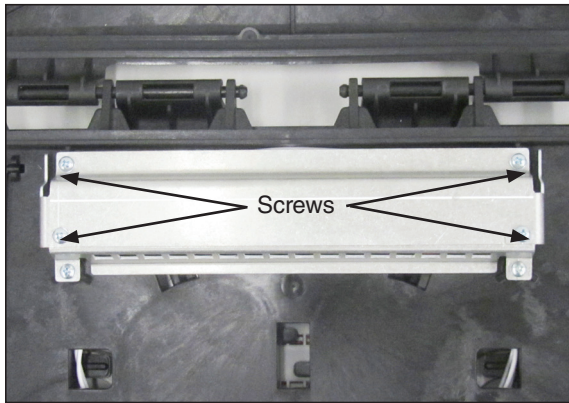

Step #25 Insert the pigtail connectors into the adapters of the bulkhead.

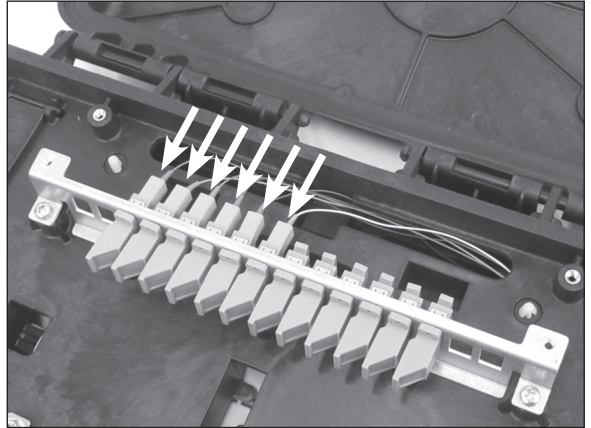

Step #23 Insert adapters into bulkhead.

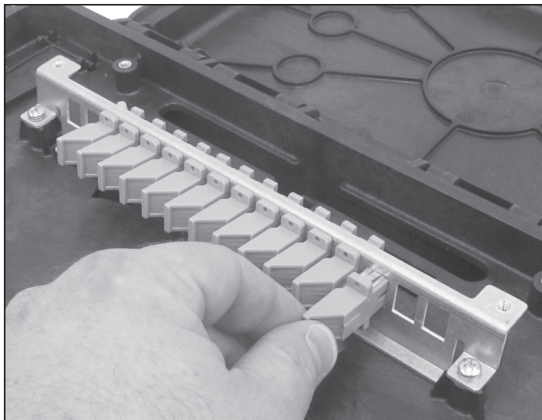

Step #26 Install the shroud onto the bulkhead with screws.

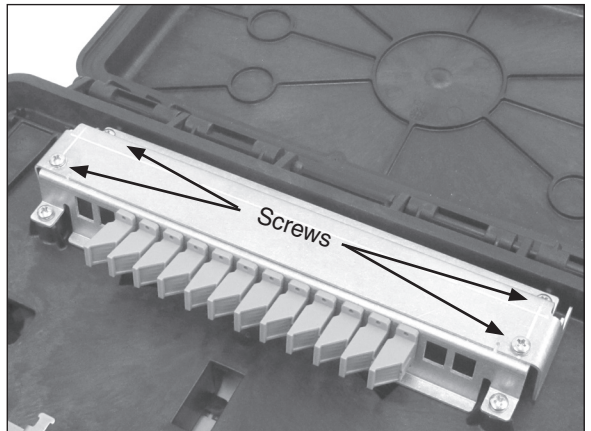

Pigtail Routing

Step #24 Route pigtails from the feed chamber to the bulkhead chamber through the window.

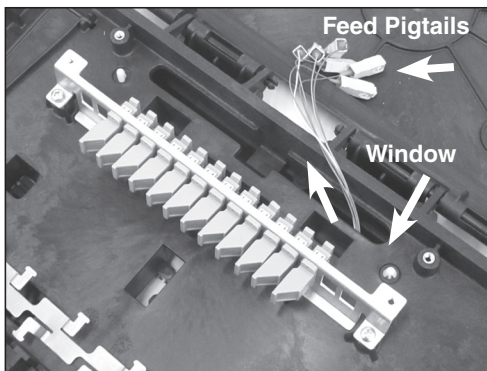

Step #27 Route the pigtails onto the splice tray.

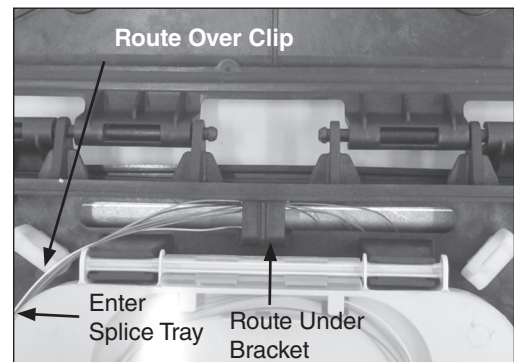

Step #28 Wrap the pigtails with felt and secure to the splice tray with the tie wraps.

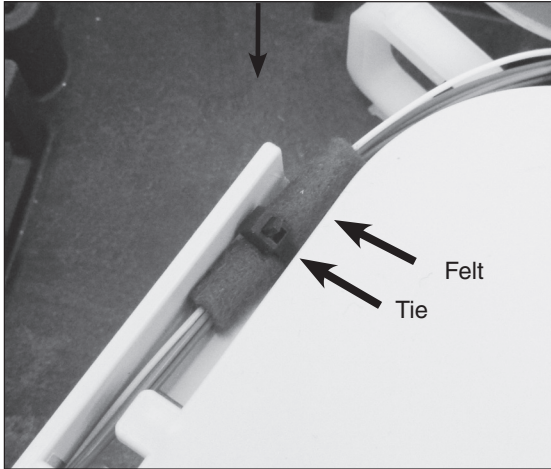

Splice Tray Management

Step #29 Secure the splice tray with the latch.

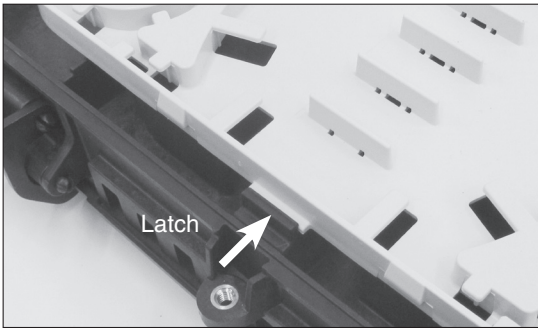

Step #30 Insert the splice blocks between the guide ribs and confirm that the tabs of each splice block are captured within the slots of the guide ribs.

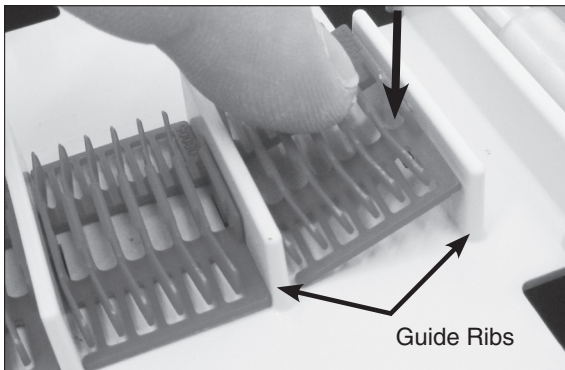

Step #31 Fiber Routing for Feed Fiber

Incoming
Fibers
1 - 12 &
25 - 36

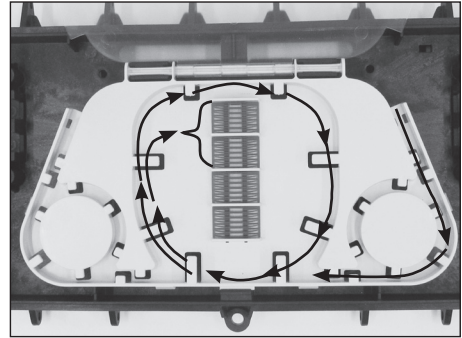

Incoming
Fibers
13 - 24 &
37 - 48

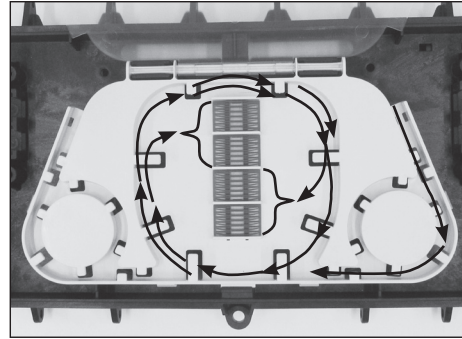

Step #32 Fiber Routing for Branch Cables or Pigtails

Outgoing
Fibers
1 - 12 &
25 - 36

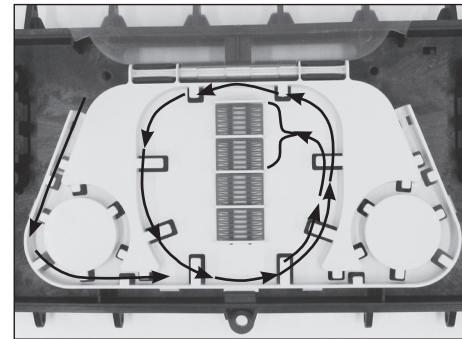

Outgoing
Fibers
13 - 24 &
37 - 48

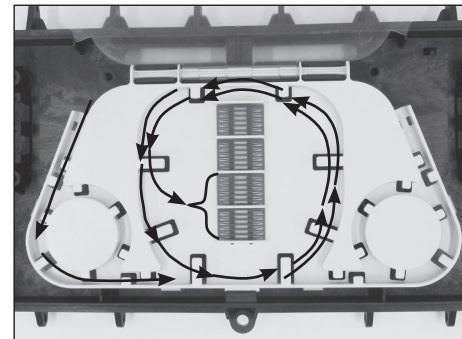

Step #33 Splice fibers per your accepted company practice.

Step #34 Secure the splice tray cover with the latches.

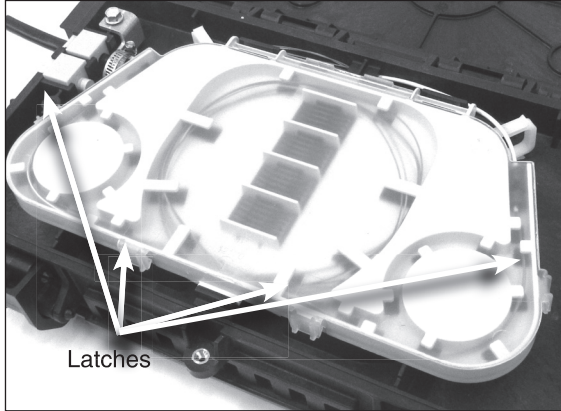

Step #35 Apply a layer of lubricant to the cover gasket surface.

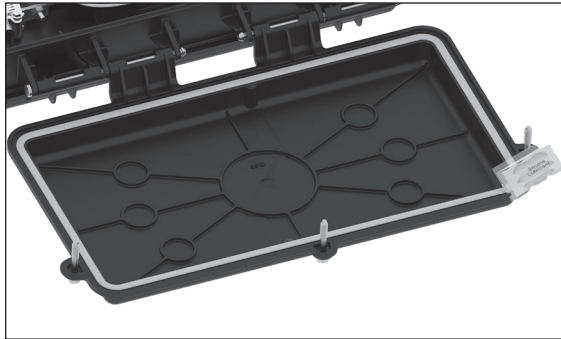

Cover Installation for Feed Chamber

Step #36 Close the chamber cover and tighten the three bolts of the cover evenly with a can wrench or nut driver until the cover is fully seated on the base.

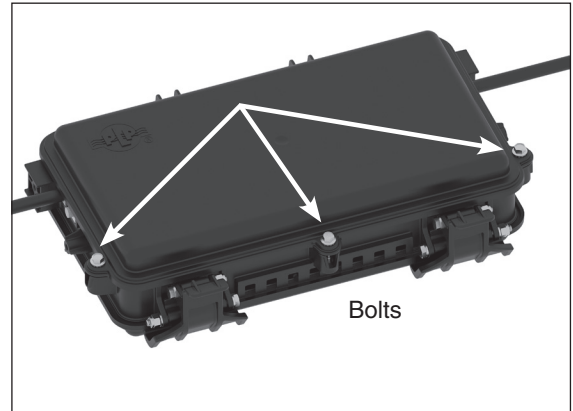

NOTE: Tighten bolts evenly by hand. **DO NOT USE POWER TOOLS TO INSTALL THE COVER.**

NOTE: When using a can wrench or a nut driver the installed torque is 35 to 40 in. lbs.

Aerial Hanger Bracket Installation

Step #37 Assemble a bug nut to each top aerial mounting bracket as shown below.

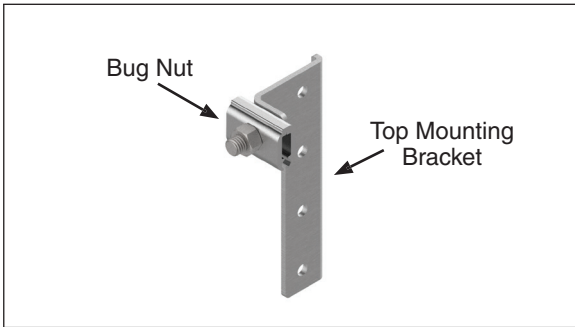
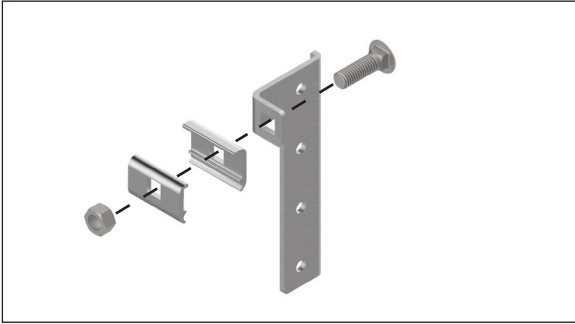

Step #38 Assemble the top mounting brackets to the bottom mounting brackets by placing the 1/4"-20 x 1" bolts in any two consecutive hole positions and securing them with the keps nuts provided.

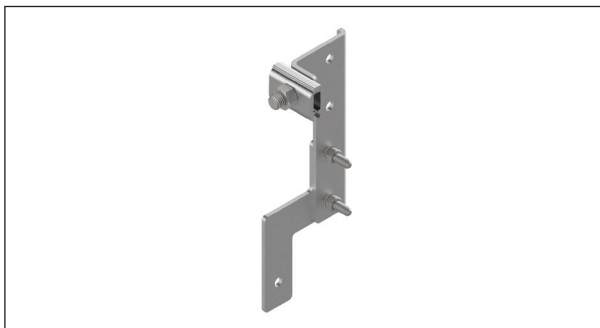
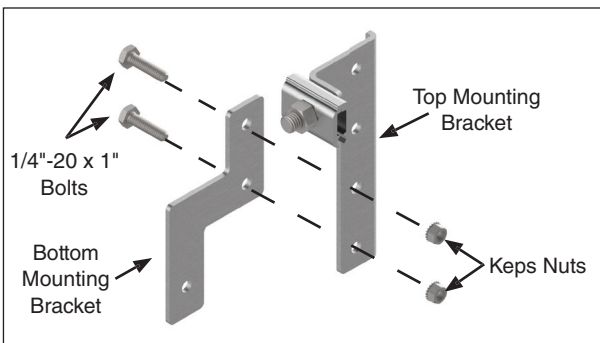

Step #39 Secure each aerial mounting bracket to the closure with a lock washer and a self-tapping bolt as shown below.

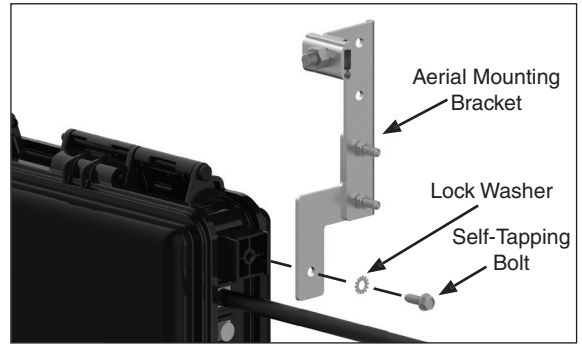

Step #40 Mount the closure to the strand by placing the bug nut clamp of each aerial hanger bracket over the strand and tightening it.

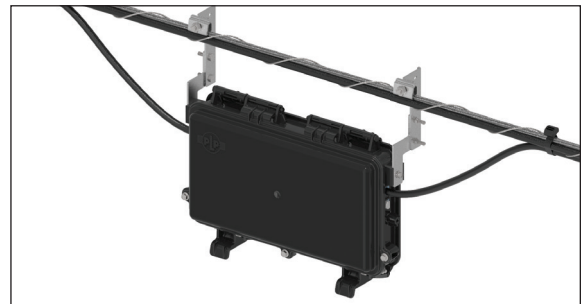

Drop Cable Support Installation

Step #41 Secure each drop cable support assembly to the closure with a lock washer and a self-tapping bolt as shown below.

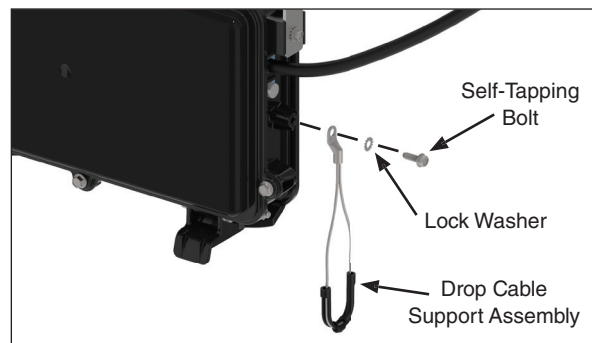

Drop Chamber Preparation – For Pre-terminated Drop Cables or Drop Cables with Field Installable Connectors ONLY

Step #42 Route the drop cables through the drop cable support as shown below.

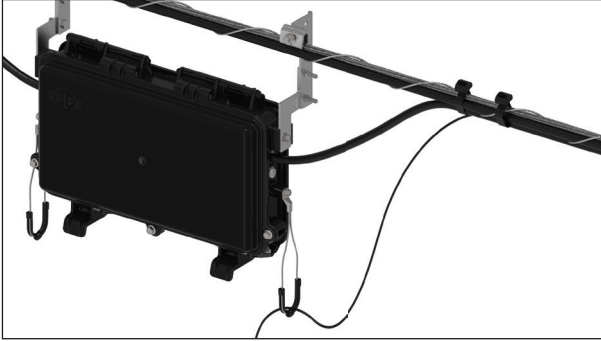

Step #43 Open up the drop chamber cover and prop the cover up with the stand.

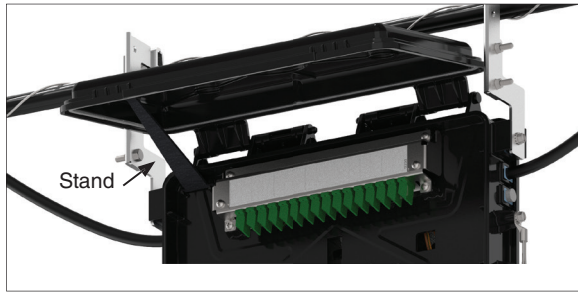

Step #44 Install the connectors of the drop cables into the adapters of the bulkhead.

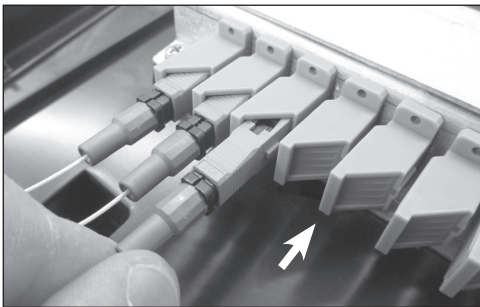

Drop Chamber Grommet Selection		Cable Diameter Range
0		SOLID, NO HOLE
1		.093" - .125" (2.4 - 3.2 mm) ROUND CABLES
2		.156" - .170" (4.0 - 4.3 mm) ROUND CABLES
3		FLAT DROP CABLE
4		.187" - .220" (4.7 - 5.6 mm) ROUND CABLES

Step #45 Install the grommets onto the drop cables. If the grommet is cut, apply lubricant to the seam as shown below.

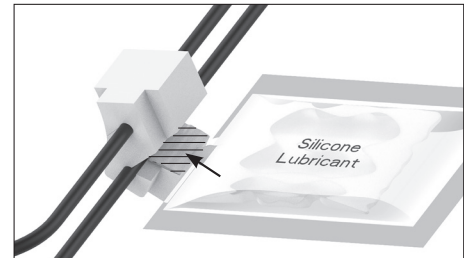

Step #46 Install plugs into any unused holes of the grommets. If the grommet is cut, apply lubricant to the seam as shown below.

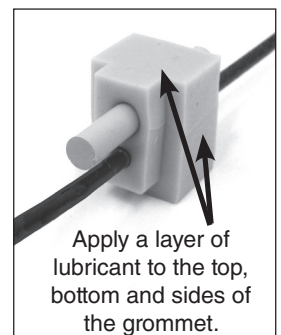
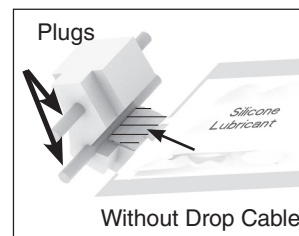
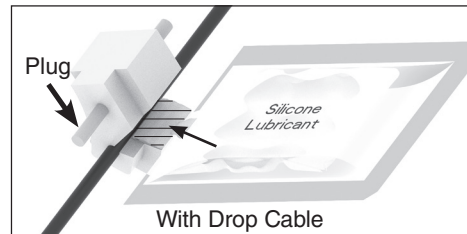

Step #47 Install the drop grommets into the grommet pockets of the closure. Apply additional lubricant to the top surface of the grommet if removed during the assembly process.

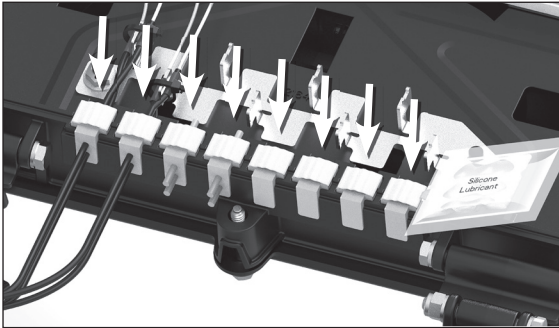

Step #49 Apply a layer of lubricant to the cover gasket surface. Close the cover and secure with latches.



Cover Installation for Drop Chamber

Step #48 Secure the drop cables to the retention bracket with the tie wraps.

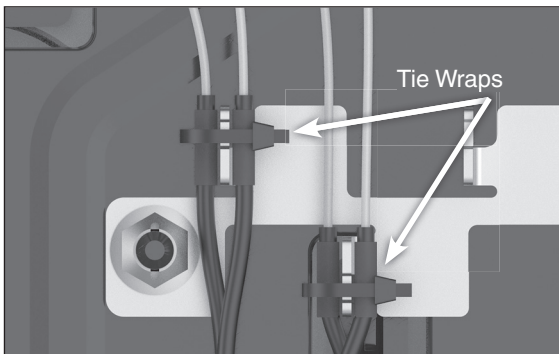

Step #50 Close the cover and secure with latches.

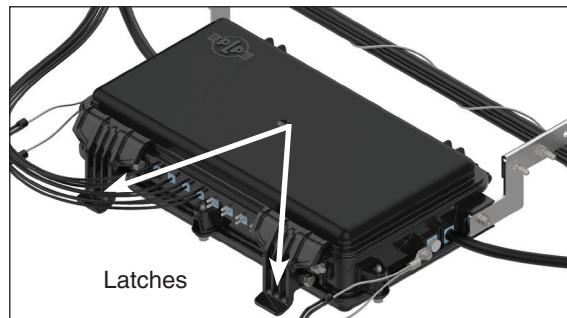

SAFETY CONSIDERATIONS

This application procedure is not intended to supersede any company construction or safety standards. This procedure is offered only to illustrate safe application for the individual. **FAILURE TO FOLLOW THESE PROCEDURES MAY RESULT IN PERSONAL INJURY OR DEATH.**

Do not modify this product under any circumstances.

This product is intended for use by trained technicians only. **This product should not be used by anyone who is not familiar with, and not trained to use it.**

When working in the area of energized lines, extra care should be taken to prevent accidental electrical contact. Be sure to wear proper safety equipment per your company protocol.

For proper performance and personal safety, be sure to select the proper size PREFORMED™ product before application.

PREFORMED products are precision devices. To ensure proper performance, they should be stored in cartons under cover and handled carefully.



PREFORMED LINE PRODUCTS

P.O. Box 91129, Cleveland, Ohio 44101 • 440.461.5200 • www.preformed.com • email: inquiries@preformed.com

SP3247-5