

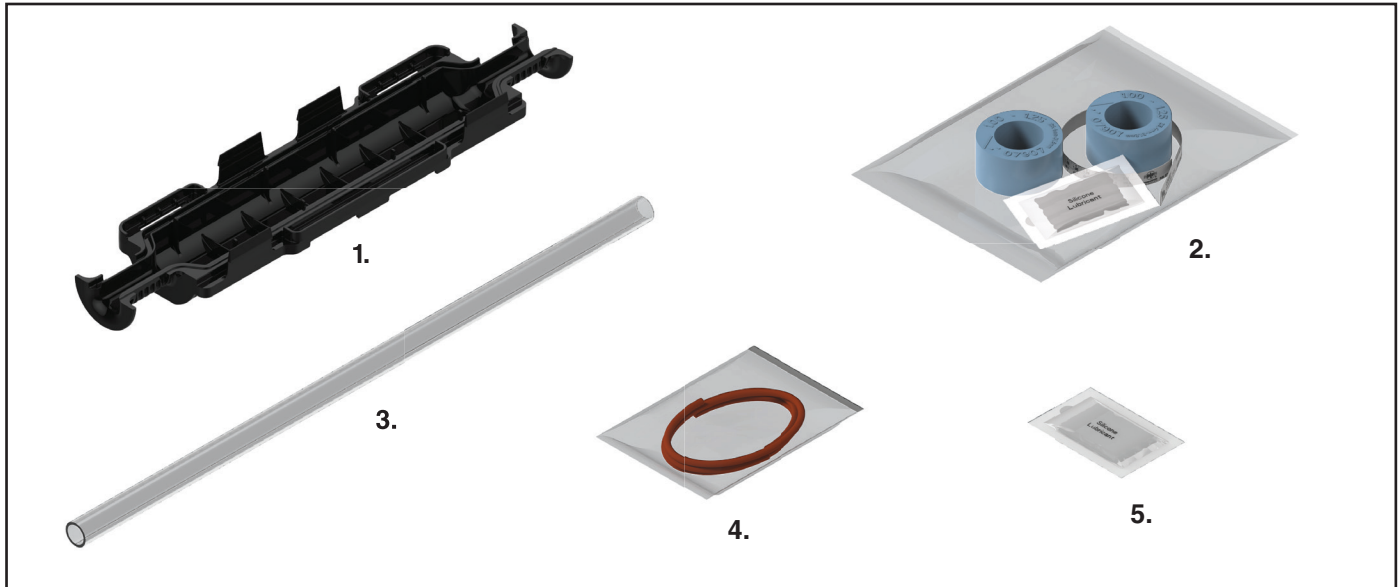

COYOTE® LCC Coupler Replacement Kit

Be sure to read and completely understand this procedure before applying product. Be sure to select the proper PREFORMED™ product before application.



NOMENCLATURE

- 1. Coupler Half (2)
- 2. 1 Hole Grommet Kit - Contains 2 Grommets (1)

- 3. Slit Transition Tubing (1)
- 4. Coupler Sealing Gasket Kit (1)
- 5. 5g Silicone Lubricant Packet (1)

TOOLS REQUIRED

- Utility Knife
- Snips
- Electrical Tape

PLP Catalog Number	Description
COYOTE® LCC Coupler Replacement Kit	
80061499	COYOTE LCC Coupler Replacement Kit

COYOTE Grommet Chart for COYOTE LCC with Coupler					
PLP Catalog Number	Cable Range Inches (mm)	Description	Image	Slitting Location	Grommet Kit Qty.
8004122	RPX Cable ONLY	2-entry grommet			1
8004152	RPX Cable and Flat Drop Cables or Tethers (Cable Range: 0.125" - 0.25"/ 3.2 - 6.4 mm)	3-entry grommet			1
8003694	1.0" - 1.25" (25.4 - 31.7 mm)	1-entry grommet			1

CLOSURE PREPARATION

Step #1 Install the ribbon splice blocks into the splice platforms as shown below.

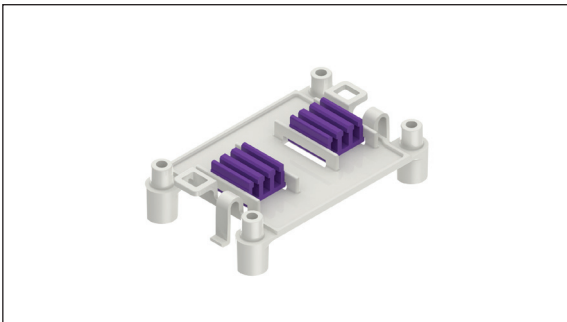
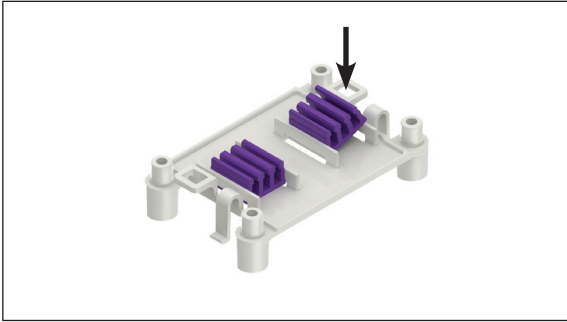

Step #2 Install the splice platforms into the bases as shown below.

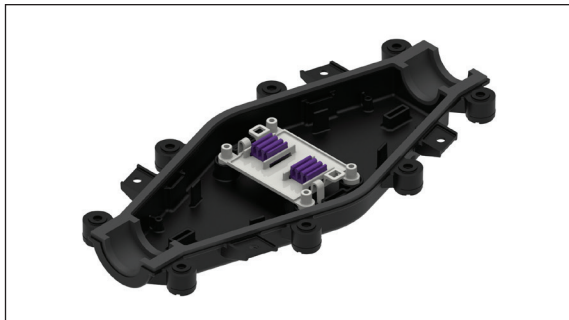
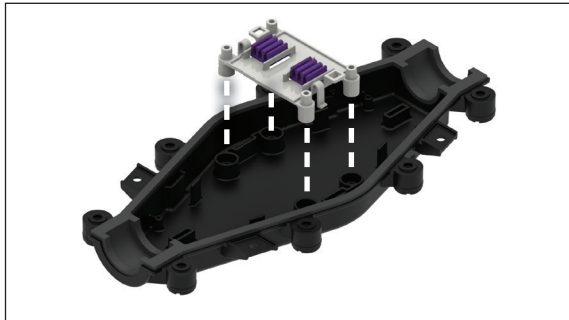

Step #3 Install a FNAP cable retention bracket at one end of each base as shown below.

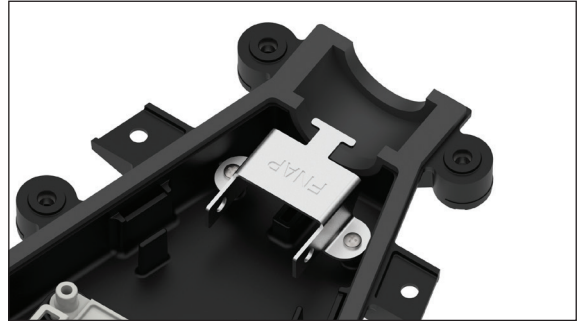
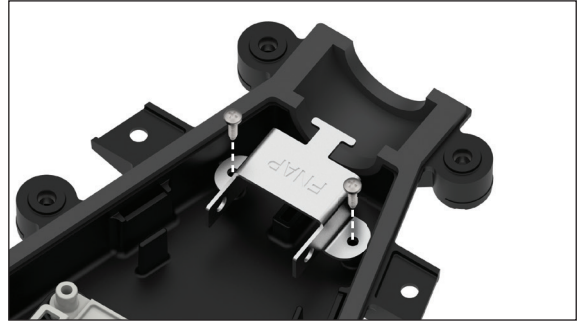

Step #4 Install cable tie wraps through the end bosses of each base as shown below.

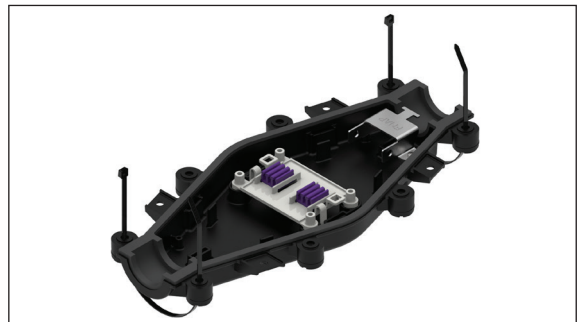

GROMMET & CABLE PREPARATION

Step #5 Grommet Slitting – Position a utility knife with the cutting edge against the top surface and cut through the grommet. **Consult the grommet chart on page 1 for slitting locations of all grommets.**

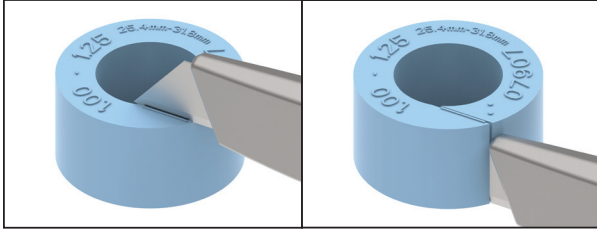

PLP Tip: Use a pen to sketch slitting lines on top surface of grommet prior to cutting.

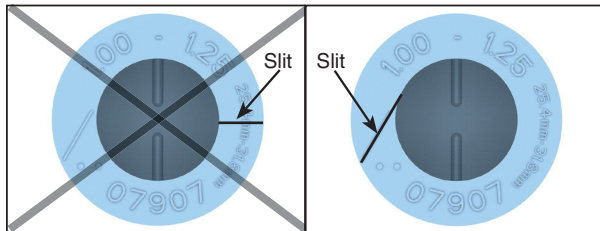

Not Correct Slitting Angle

Correct Slitting Angle

Step #6 Identify the area of the RPX cable where the fiber damage has occurred and place a mark on the cable at this location.

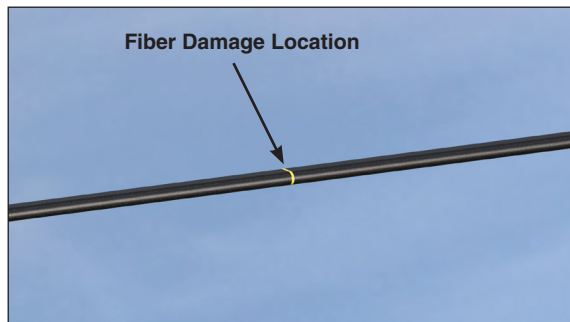

Step #7 Measure and mark the RPX cable 16" (41 cm) away from the fiber damage location in both directions.

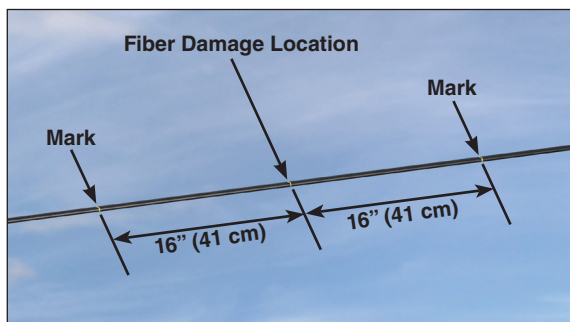

Step #8 Remove half of the RPX cable sheath between the marks per the cable manufacturer's recommended practice.

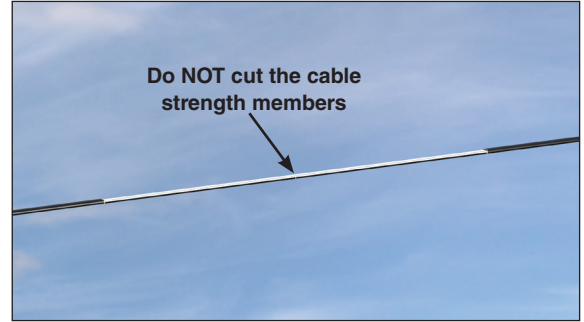

Step #9 Identify the damaged 24 fiber ribbon(s) at the initial marked location and cut the ribbon(s).

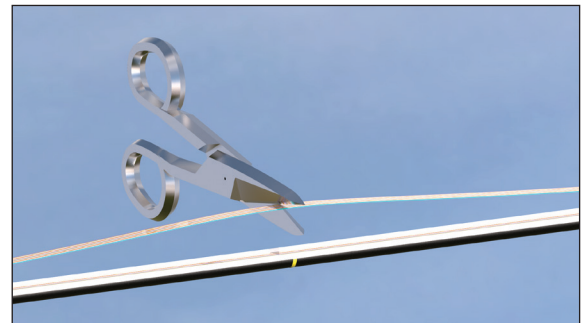

Step #10 Obtain a piece of 12 fiber ribbon that is a minimum of 52" (132 cm) in length for each damaged 12 fiber ribbon.

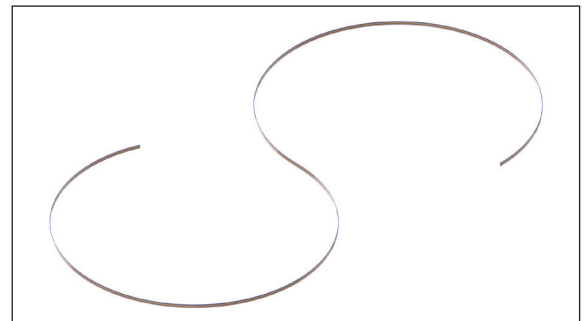

Step #11 Split the cut ribbons of the RPX cable into 12 fiber ribbons. Splice the ends of each matching cut 12 fiber ribbon to the ends of a 52" (132 cm) long piece of 12 fiber ribbon per your standard company practice.

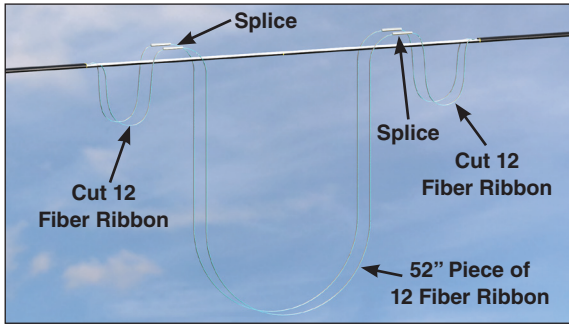

Step #14 Secure the transition tube with electrical tape so the slack ribbons do not exit the tubing through the slit.

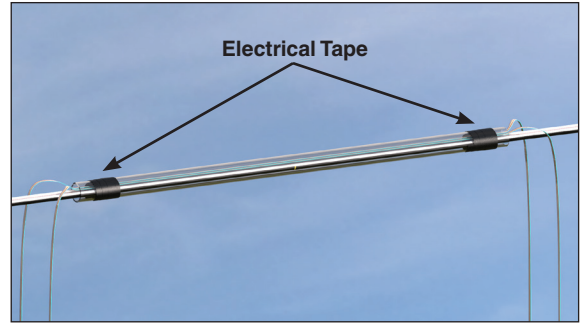

COUPLER INSTALLATION

Step #12 Install the slit transition tubing over the RPX cable. Center the tubing with the mark where the fiber was damaged and rotate the tubing so that the slit is facing upward.

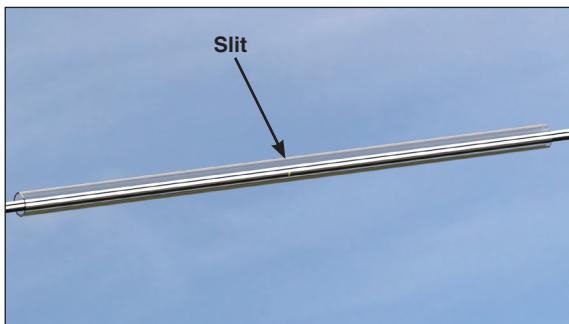

Step #13 Insert the slack ribbons through the slit of the transition tube. Center the slack ribbons within the tube.

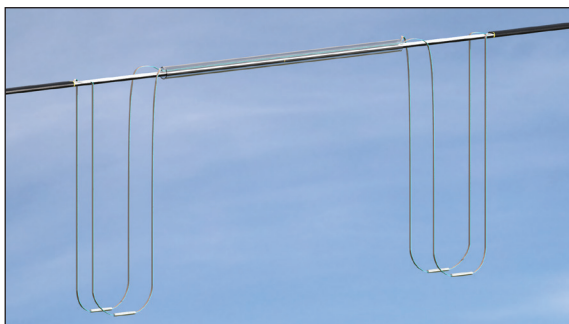

Step #15 Install a gasket into each coupler half as shown below.

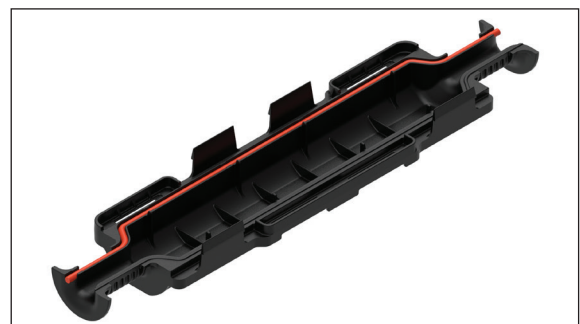

Step #16 Center the coupler halves with the center of the transition tubing and snap the halves together.

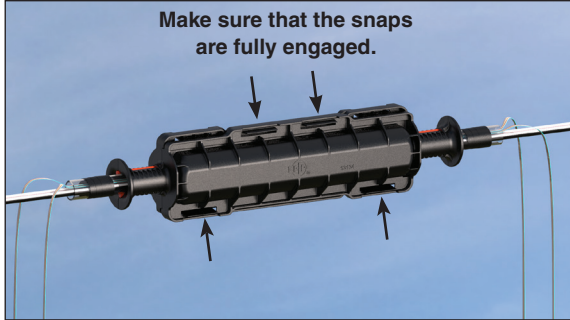

Step #17 Apply a thin coat of silicone lubricant to the outer surface of each slit 1 hole grommet and install the grommets onto the coupler as shown below.

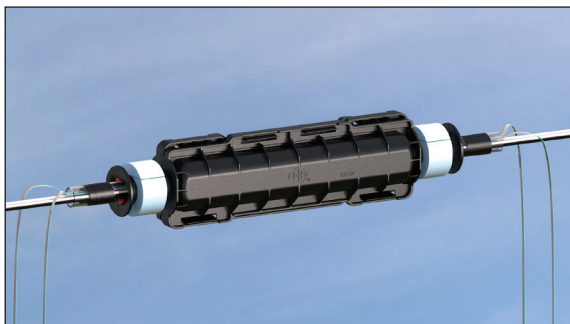
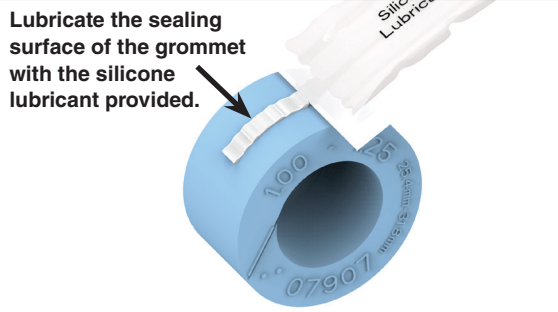

Step #18 Apply a thin coat of silicone lubricant to the outer surface of each slit RPX 2 hole grommet and install the grommets onto the RPX cable as shown below.

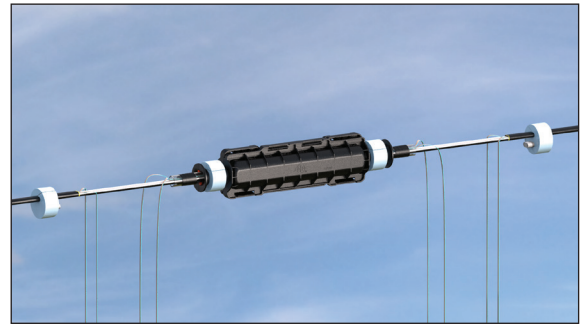
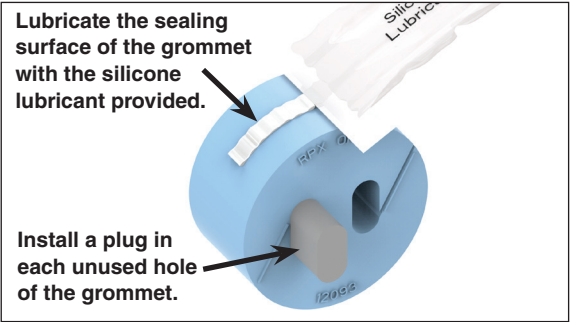

CLOSURE INSTALLATION

Step #19 Align the grommets with the grommet pockets of each COYOTE® LCC base and secure each base in place with the cable tie wraps.

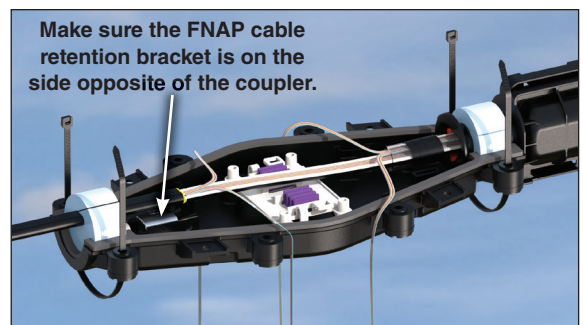

Step #20 Secure the RPX cable to the FNAP cable retention brackets in each closure base with the hose clamps provided.

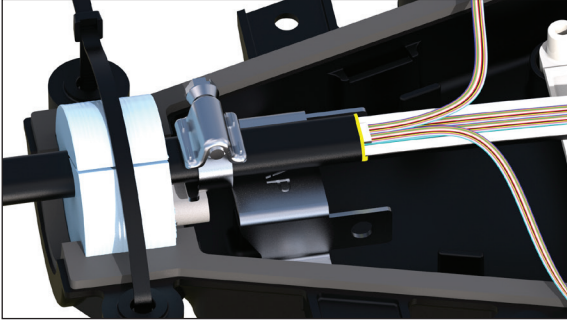

Step #21 Route the ribbons under the cable and insert the splices into the splice block in each closure base as shown below.

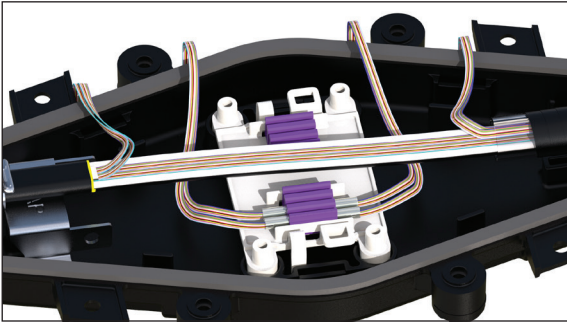

Step #22 Route the ribbons in each closure base as shown below.

Routing Ribbons From Cable to Splice

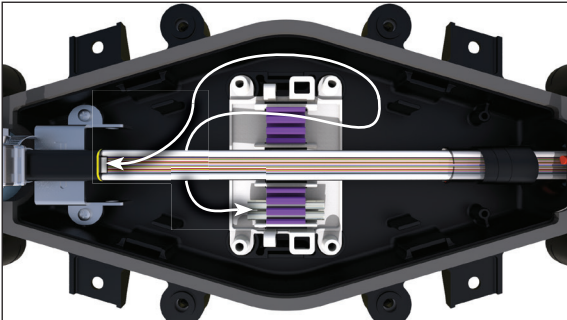

Routing Ribbons From Coupler to Splice

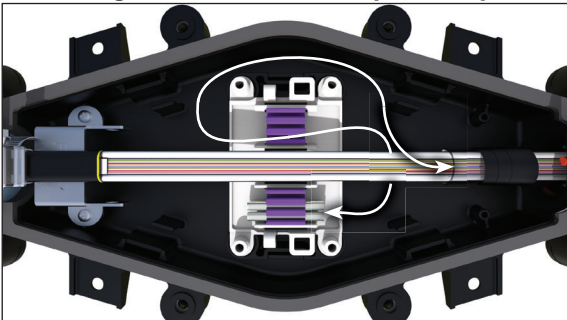

Step #23 Place the ribbons in the LITE-GRIP® retention sleeve and secure the sleeve in the routing channel with a retention clip.

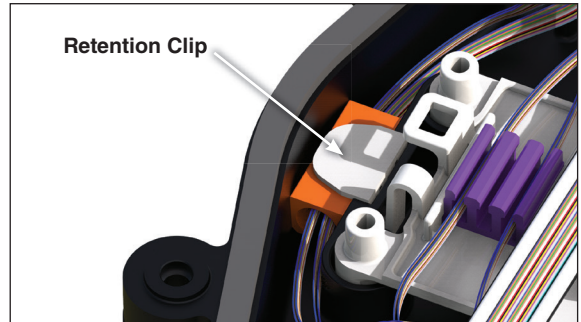
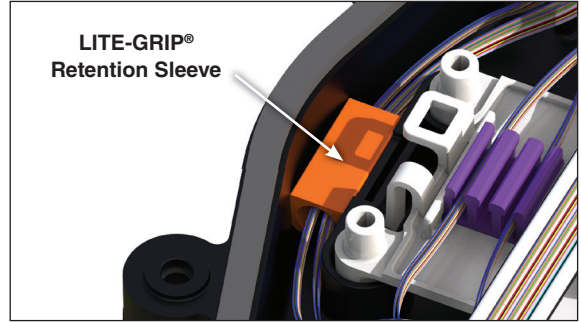

Step #24 Cut and remove the cable tie wraps from each closure base.

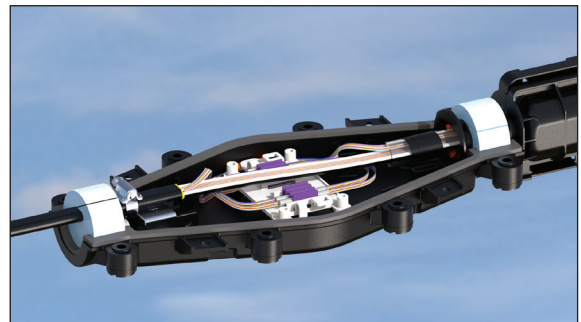
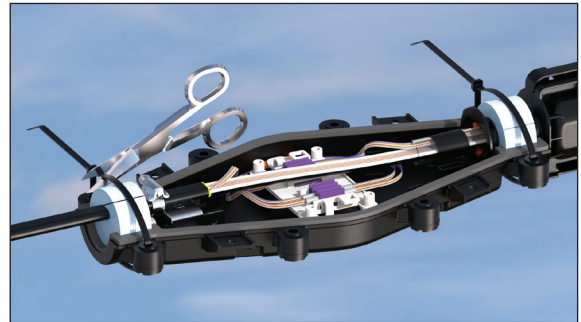

Step #25 Apply a thin coat of lubricant to each closure cover and base gaskets with the silicone lubricant provided.

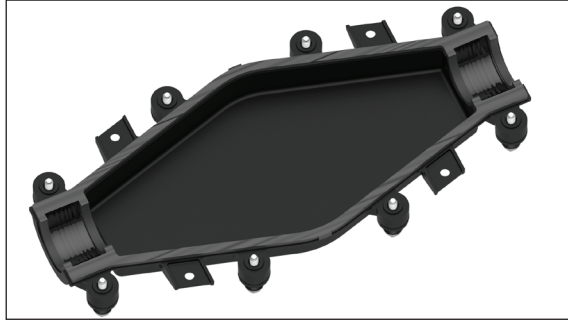
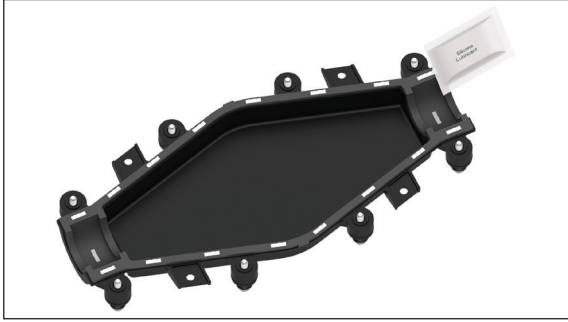

Step #27 Fully assembled COYOTE® LCC Coupler System shown below.

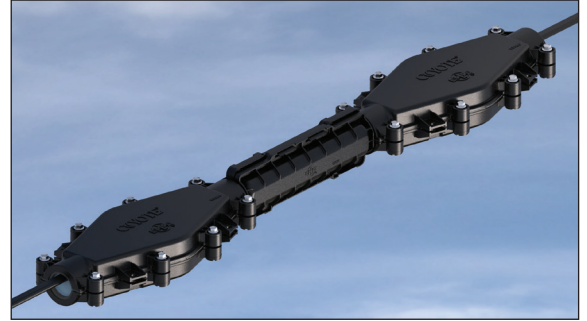

Step #26 Secure the closure covers to the bases by hand tightening the hex head bolts.

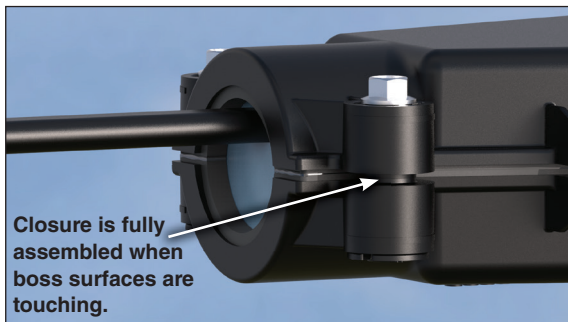
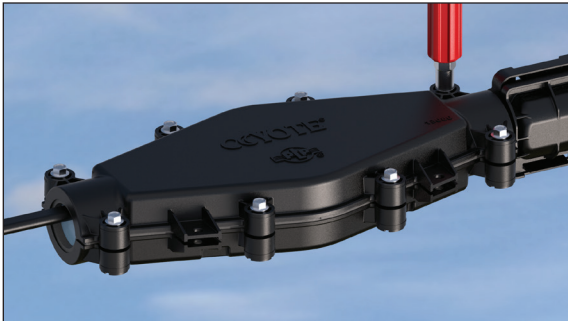

Closure is fully assembled when boss surfaces are touching.

SAFETY CONSIDERATIONS

This application procedure is not intended to supersede any company construction or safety standards. This procedure is offered only to illustrate safe application for the individual.

FAILURE TO FOLLOW THESE PROCEDURES MAY RESULT IN PERSONAL INJURY OR DEATH.

Do not modify this product under any circumstances.

This product is intended for use by trained technicians only. **This product should not be used by anyone who is not familiar with, and not trained to use it.**

When working in the area of energized lines, extra care should be taken to prevent accidental electrical contact. Be sure to wear proper safety equipment per your company protocol.

For proper performance and personal safety, be sure to select the proper size PREFORMED™ product before application.

PREFORMED products are precision devices. To ensure proper performance, they should be stored in cartons under cover and handled carefully.



PREFORMED LINE PRODUCTS

P.O. Box 91129, Cleveland, Ohio 44101 • 440.461.5200 • preformed.com • email: inquiries@preformed.com

SP3517