

APPLICATION PROCEDURE & SAFETY CONSIDERATIONS **PREFORMED** LINE PRODUCTS



SEPTEMBER 2004

Super SERVICEAL® Closure

**NOTE: THIS CLOSURE MAY BE USED ONCE -
REPLACE WITH A NEW FILLED CLOSURE AFTER REENTERING**

SIZING PROCEDURE

With the inserts removed the groove will accept wires up to 0.61" (15.5 mm) diameter. With the inserts installed, the groove will accept wires up to 0.50" (13 mm)

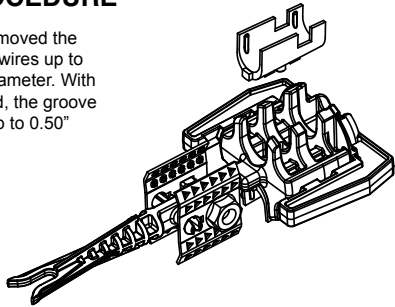

SERVICE WIRE

①

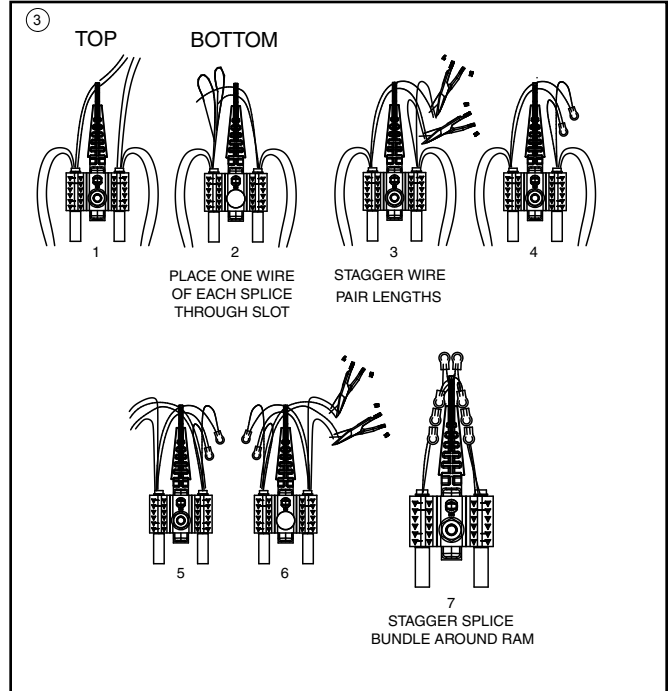
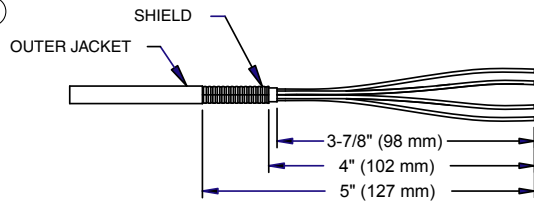

②

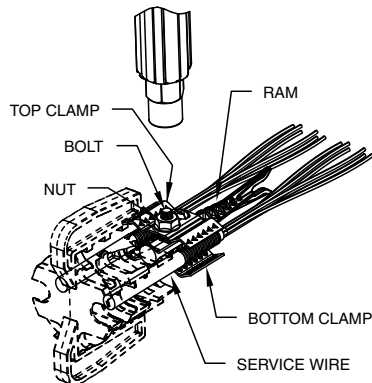

④

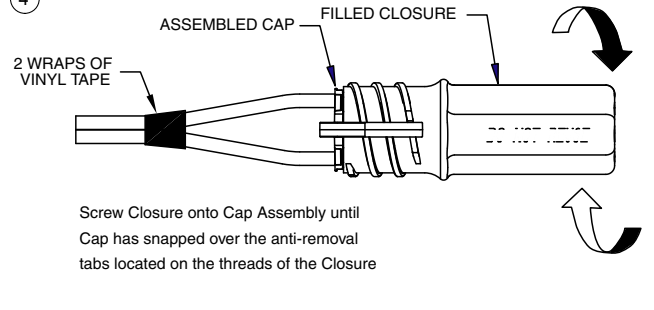

PREFORMED LINE PRODUCTS

P.O. Box 91129, Cleveland, Ohio 44101 • 440.461.5200 • www.preformed.com • e-mail: inquiries@preformed.com