

Universal Top-of-Pole Mount 4 Modules (UTPM4) Module Type G

ASSEMBLY INSTRUCTIONS

**step-by-step
assembly and installation**

Universal Top-of-Pole Mount For 4 Modules (UTPM4) For Module Type G

WARNING

Follow the procedures and precautions in these instructions carefully.

About the product

The UTPM4 for module Type G is designed for a wide range of Module sizes, from 37-42" in width to 61-67" in length. The Universal Top-of-Pole support structure mounts on 4 inch SCH40/80 galvanized steel pipe (installer supplied).

Pipe size and foundation requirements are based on several factors including the array surface area, maximum design wind speed, exposure category, soil type, steepest expected tilt angle, and above-ground clearance.

For foundation and pipe size recommendations on a specific installation, please:

Visit www.preformed.com and select the TPM online configurator.

Contact us by Phone: 800-260-3792

Send an Email request: info@plpsolar.com

About these instructions:

- These instructions are intended to be used by individuals with sufficient technical skills for the task. Knowledge and use of hand tools, measuring devices and torque values is also required.
- These instructions include various precautions in the forms of Notes, Cautions, and Warnings. These are to assist in the assembly process and/or to draw attention to the fact that certain assembly steps may be dangerous and could cause serious personal injury and/or damage to components. Following the step-by-step procedures and these precautions should minimize the risk of any personal injury or damage to components while making the installation not only safe but an efficient process.

Periodic Inspection

Periodic re-inspection is a recommended system maintenance procedure to check for any loose components and any corrosion. If any loose components and any corrosion is found, the affected components are required to be replaced immediately, with the original mounting system manufacturer's component parts.

Required Tools

- 7/16 inch wrench or socket for 1/4 inch module hardware
- 9/16 inch wrench or socket for 3/8 inch hardware
- 3/4 inch wrench or socket for 1/2 inch hardware
- 1-1/8 inch wrench or socket for 3/4 inch Pivot Bolt hardware
- Torque wrench
- Ratchet wrench
- Ratchet extension bar
- 3 to 6 foot level
- Tape Measure
- Square

UTPM4 Type G Main Components

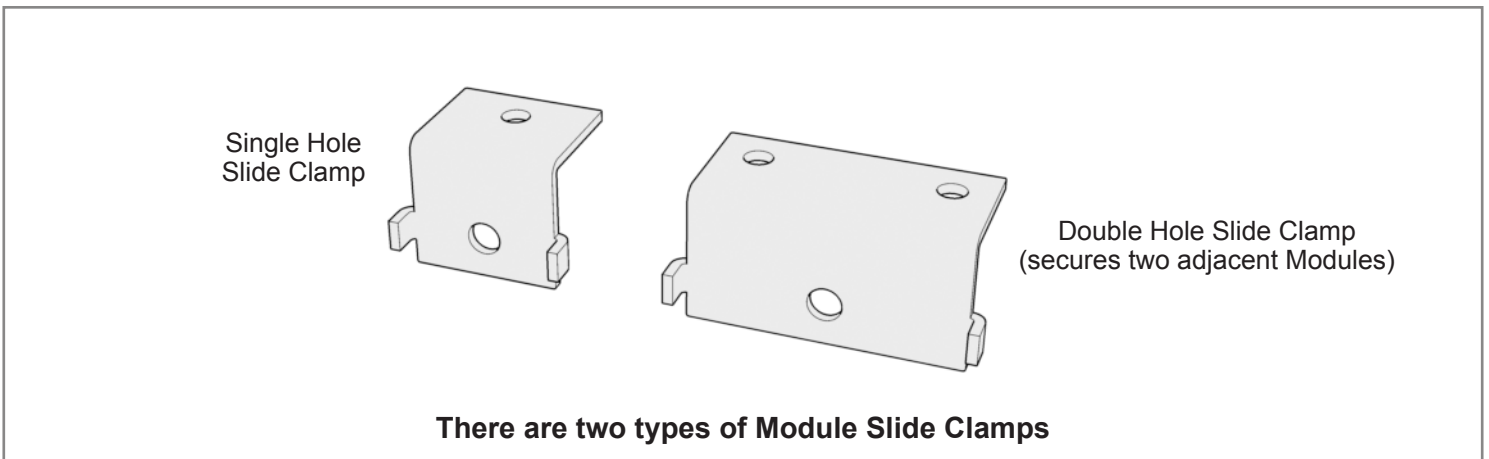
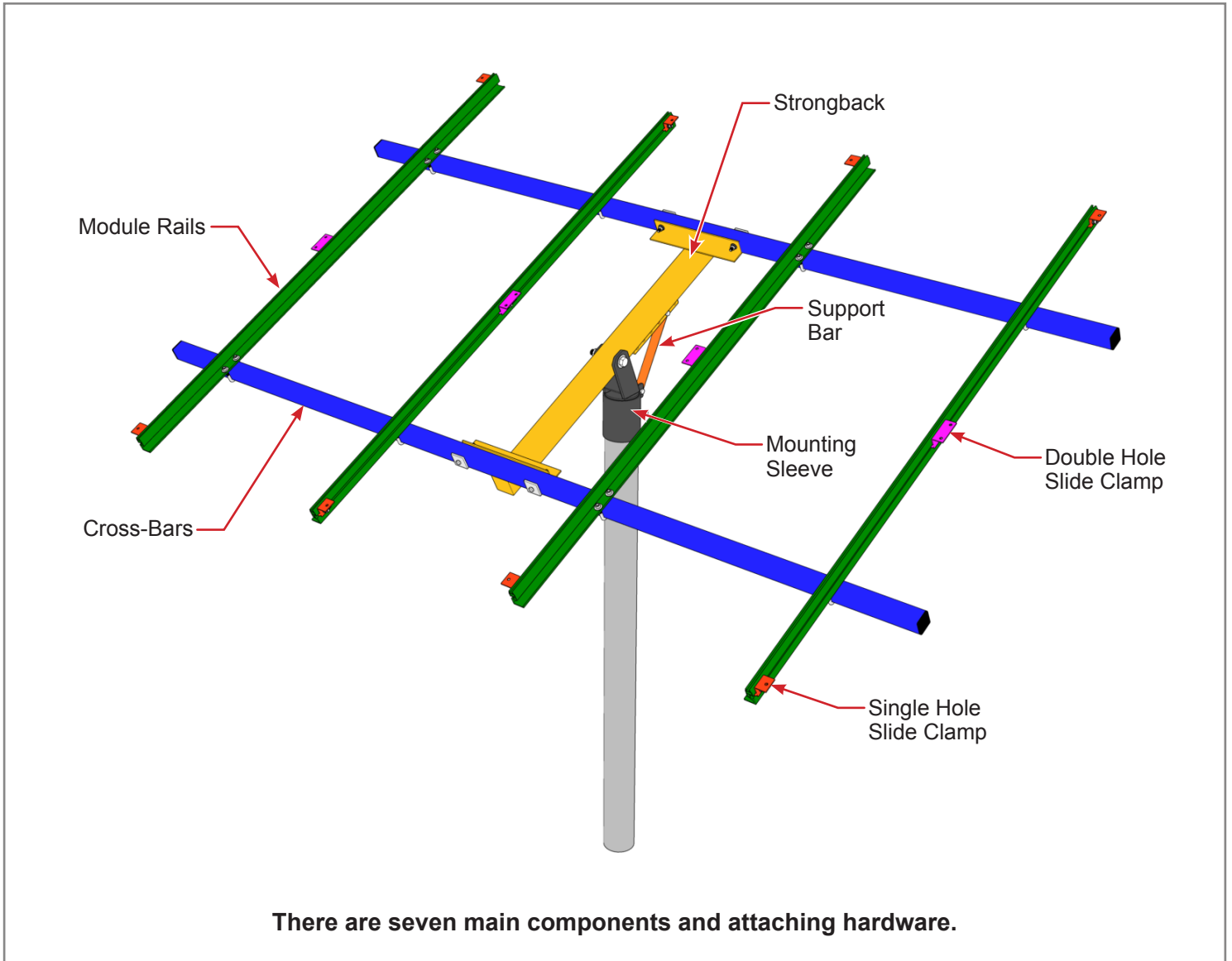

Universally adjustable to accommodate a range of PV Module sizes

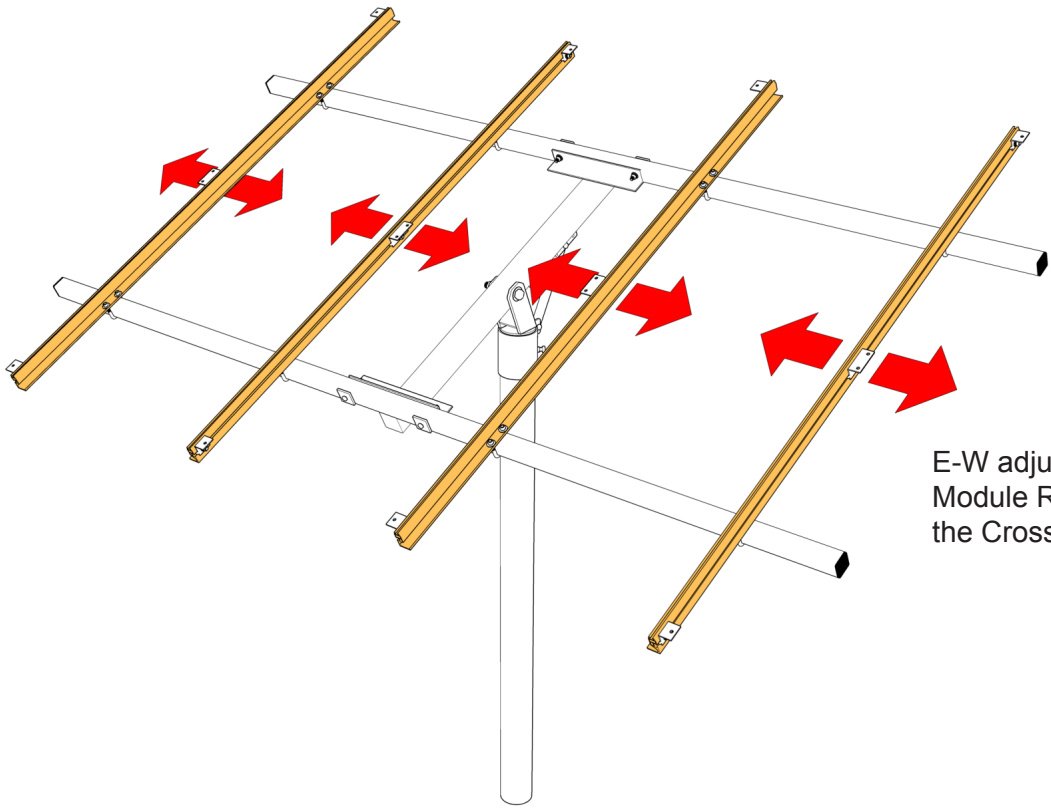

E-W adjustability of Module Rails along the Cross-Bars.

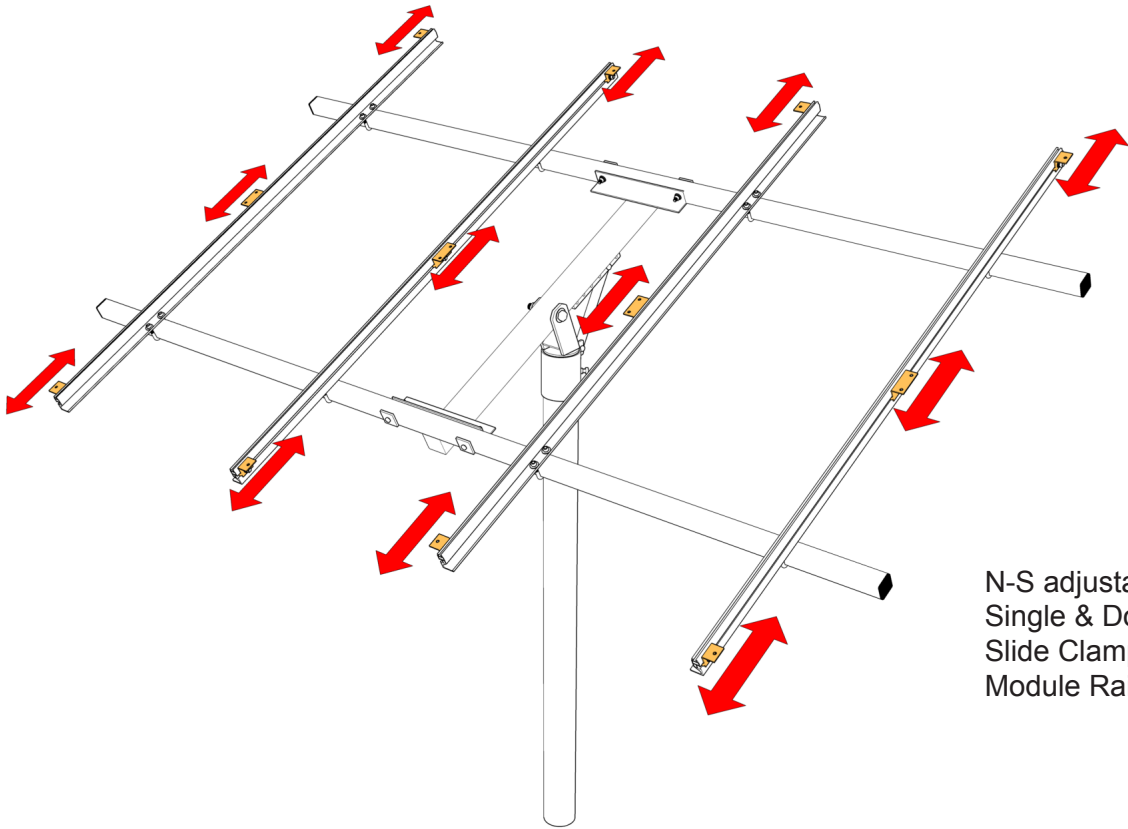

N-S adjustability of Single & Double Hole Slide Clamps along the Module Rails.

UTPM4 Type G Parts Identification

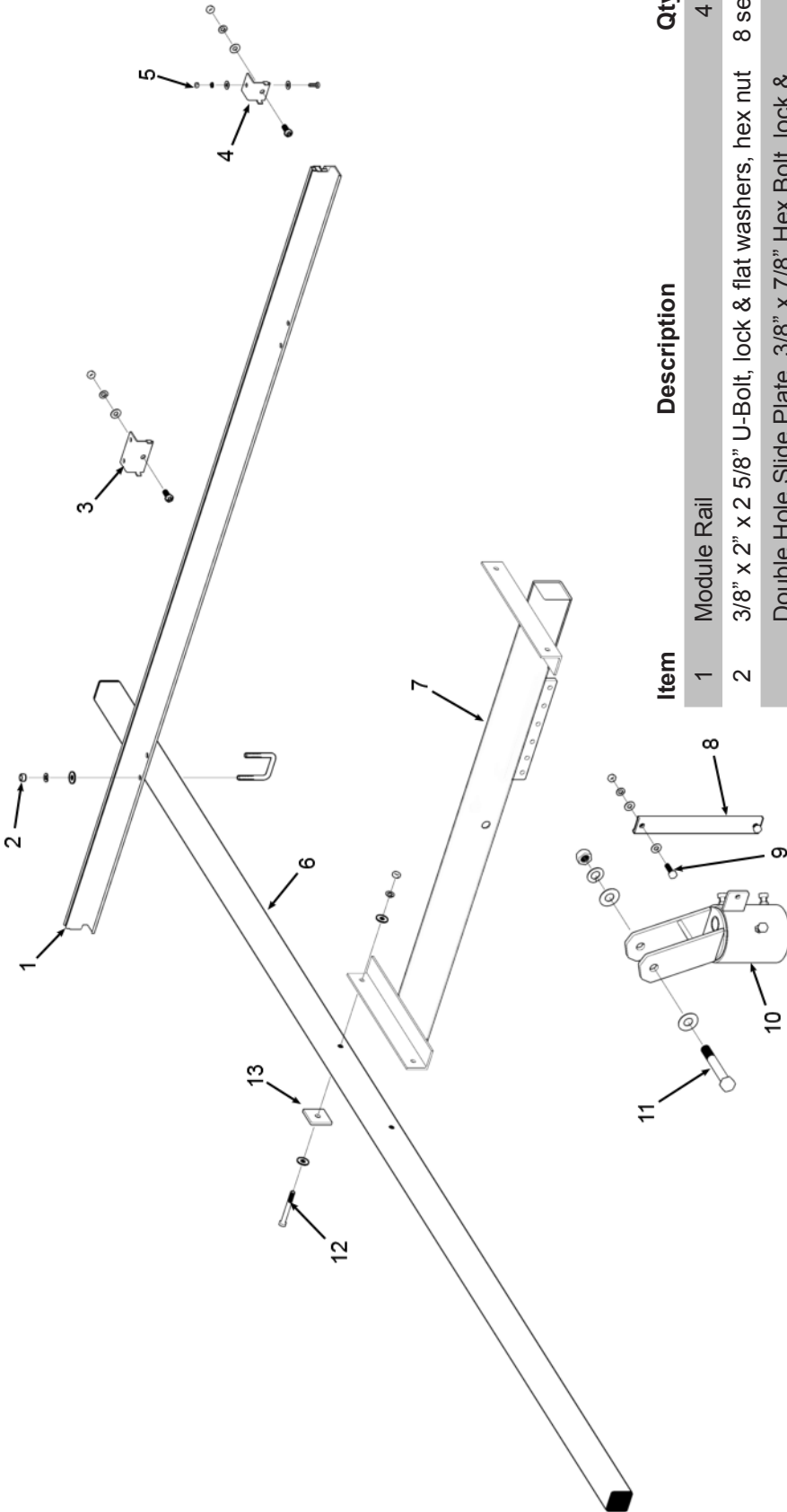

Item	Description	Qty
1	Module Rail	4
2	3/8" x 2" x 2 5/8" U-Bolt, lock & flat washers, hex nut	8 sets
3	Double Hole Slide Plate, 3/8" x 7/8" Hex Bolt, lock & flat washer, hex nut	4 sets
4	Single Hole Slide Plate, 3/8" x 7/8" Hex Bolt, lock & flat washer, hex nut	8 sets
5	1/4" x 3/4" Bolt, lock & flat washers (2 flat washers), secures PV Module	16 sets
6	Cross-Bar	2
7	Strongback	1
8	Support Bar	1
9	3/8" x 1-3/4" Bolt, lock & flat washers (2 flat washers)	2 sets
10	Mounting Sleeve	1
11	3/4" x 5-1/2" Pivot Bolt, lock & flat washers (2 flat washers)	1 set
12	3/8" x 3 1/4" Bolt, lock & flat washers (2 flat washers)	4 sets
13	3/8" Square washer	4

1 Calculate Site Specific Dimensions

NOTE

When selecting mounting holes, make certain that the hole diameters accept 1/4" hardware as it will be used to secure the PV Modules to the system.

Refer to site specific PV Module and:

- Decide on desired/preferred mounting holes.
- Choose mounting hole set. Measure from the hole centers and enter dimension "D".
- Measure from the module edge to the hole center and enter dimension "B".

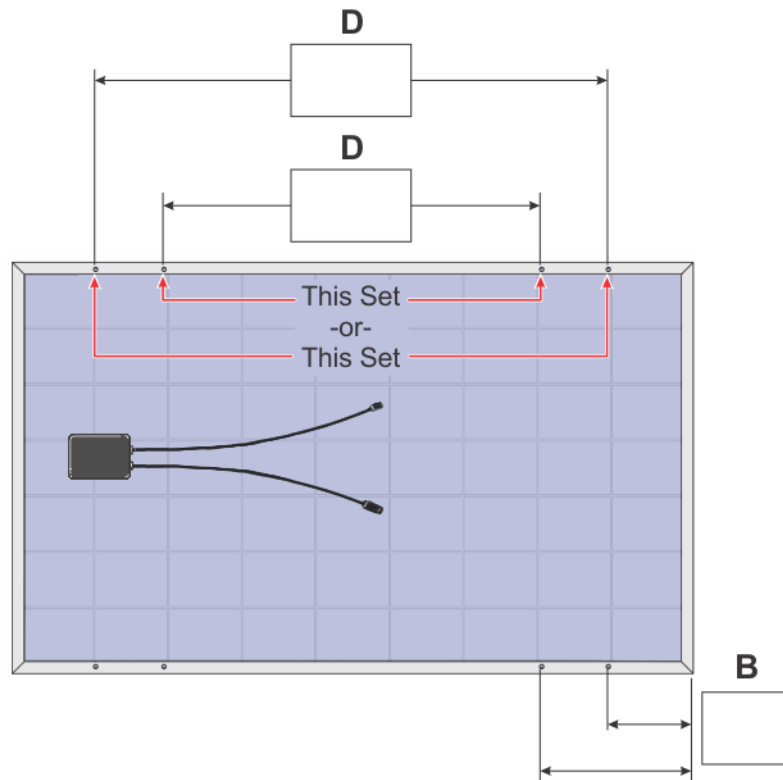

The dimensions must be taken from the site-specific Modules. The dimensions will be used to calculate the Module Rail positions.

2 Calculate and Mark the Rail Positions on Cross-Bars

Use the worksheet on the next page to calculate Rail positions on the Cross-Bars. Enter the two dimensions from above and complete the calculations. The resulting dimensions set the Inboard ("I") and Outboard ("O") Rail positions which will be measured and marked on the Cross-Bars.

2 Calculate and Mark the Rail Positions on Cross-Bars (continued)

Module Rail Positioning Calculator: Locate positions **I** & **O**

Factor	Description
A	.25" or one-half of the .50" gap between Modules.
B	Module mounting hole dimension "B" from previous page.
C	1.0" distance from edge of Module Rail to center of Slide Plate mounting hole.
D	Module mounting hole dimension "D" from previous page.
I	Distance from center of Cross-Bar to edge of Module Rail.
O	Distance from edge to edge of Module Rails.

Calculate Position **I**

$$\boxed{.25"} + \boxed{} + \boxed{1.0"} = \boxed{}$$

A B C Position **I**

Calculate Position **O**

$$\boxed{} - \boxed{2.0"} = \boxed{}$$

D C x 2 Position **O**

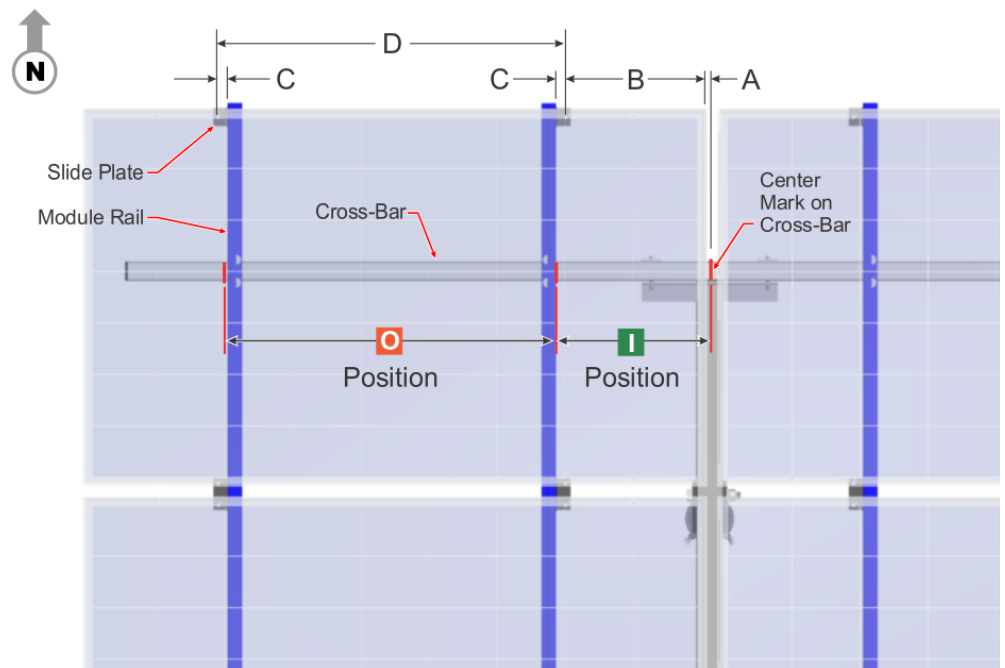
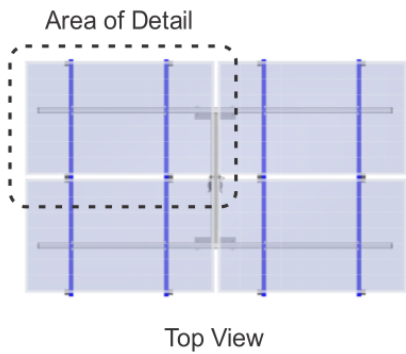

3 Mark the Cross-Bars

NOTE
Use precision when measuring and marking the Rail positions on the Cross-Bars.

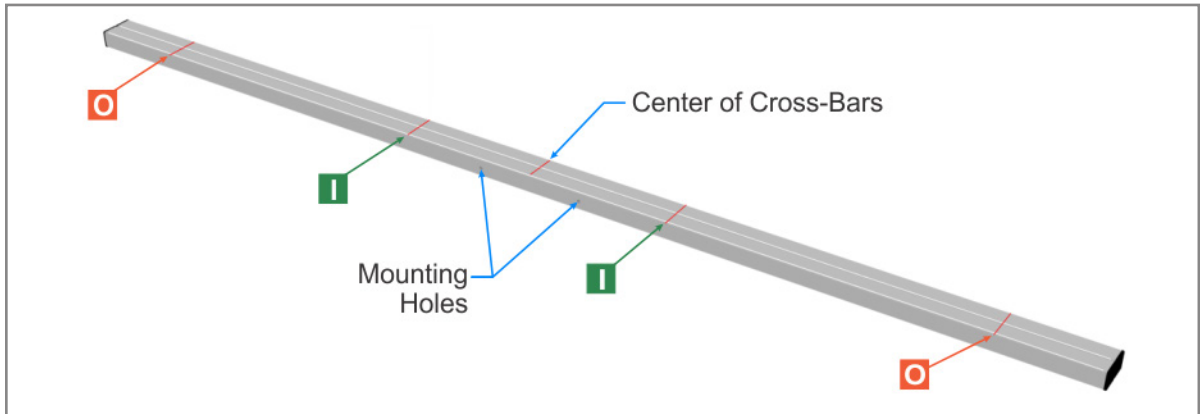

Measure and mark the center of the Cross-Bars, then use the calculated dimensions I and O from the previous page to mark off their respective Rail positions on the Cross-Bars. The image below shows these marks and their relationship to the Cross-Bars and Rails after assembly.

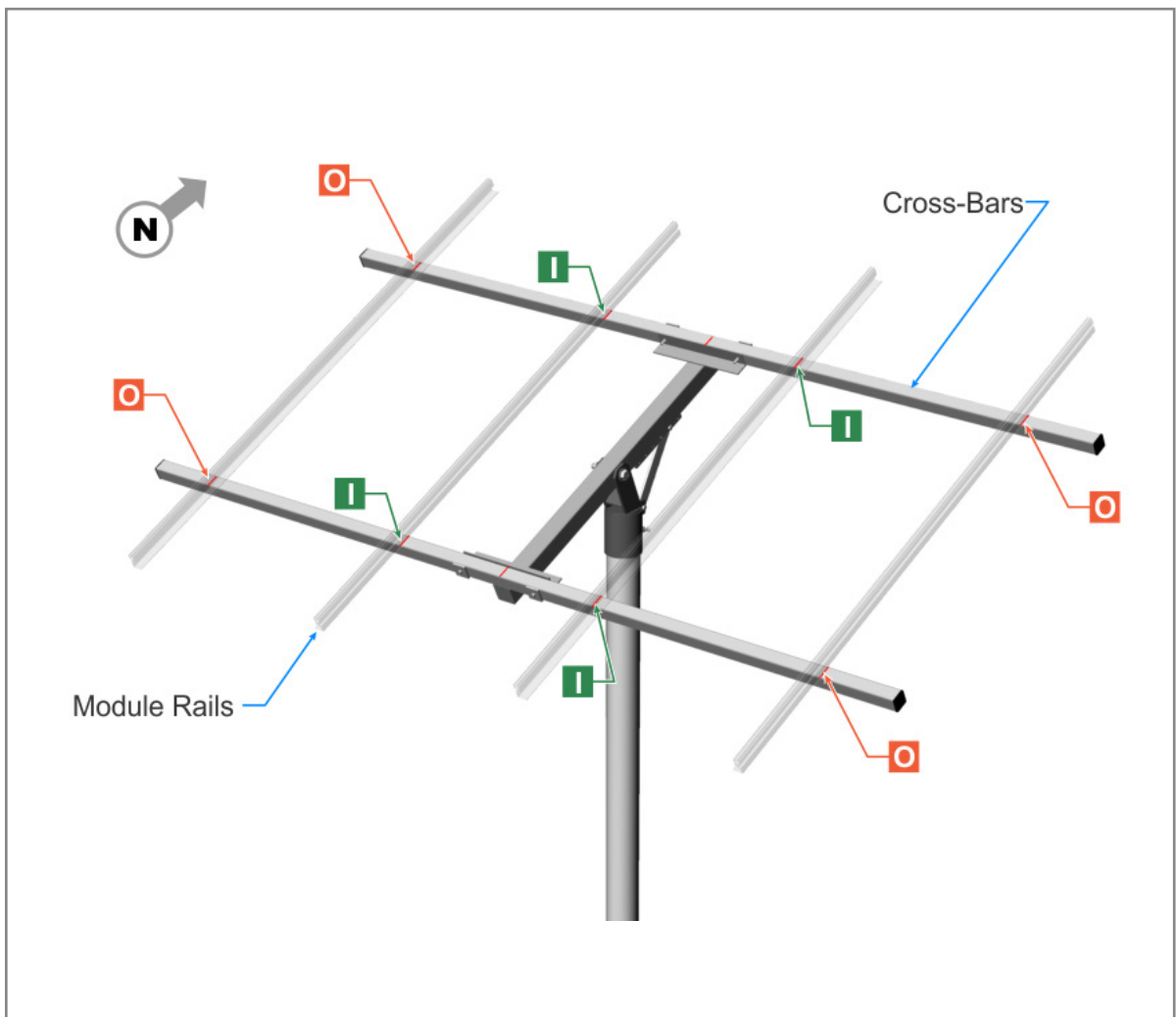

4 Mark the Double Hole Slide Plate Positions on the Rails

NOTE
Use precision when measuring and marking the Double Hole Slide Plate positions on the Module Rails.

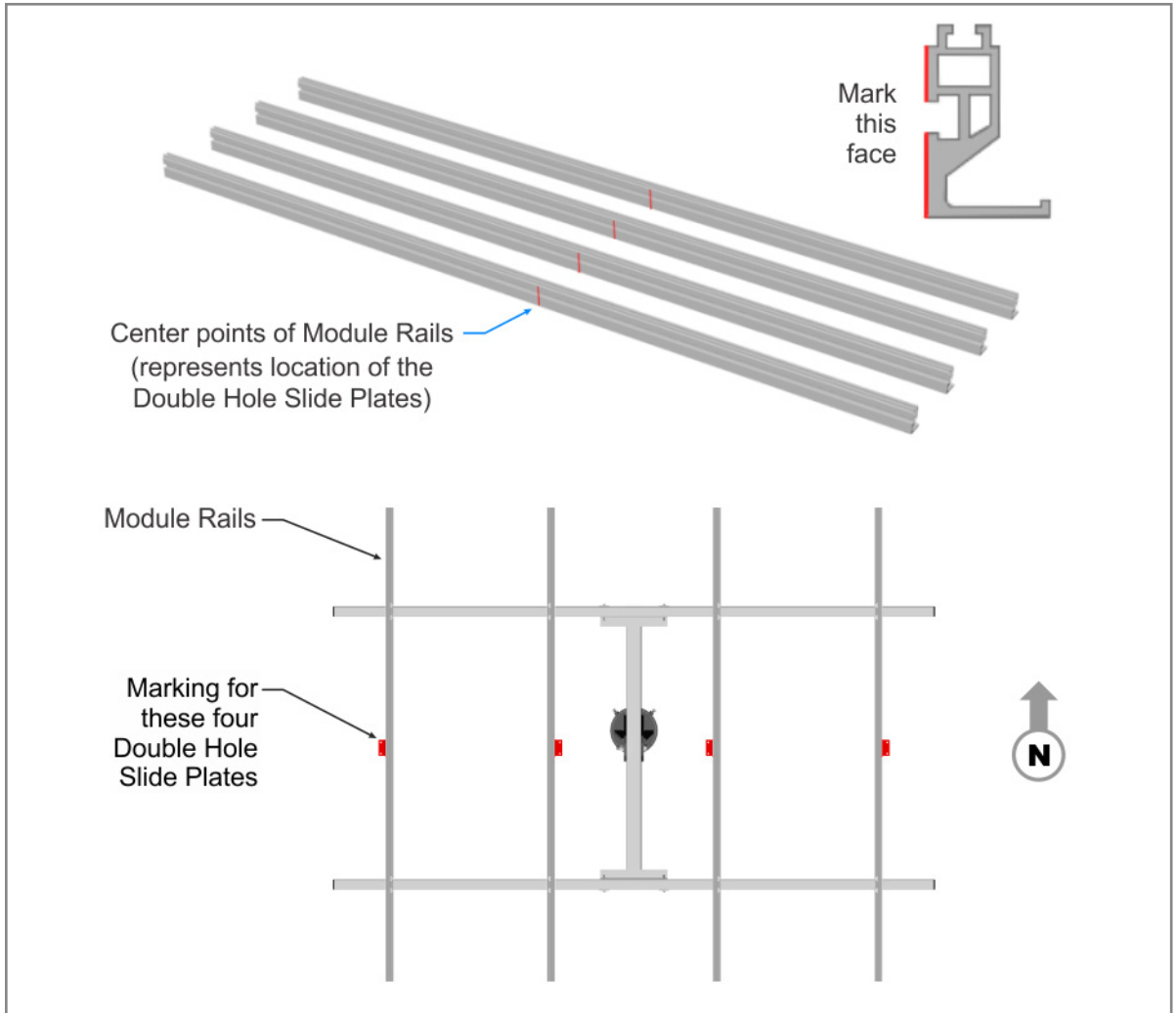

Locate the center of the Rails and mark as shown above. These marks are for the four (one-per Rail) Double Hole Slide Plates only. The additional Slide Plates do not require marks as they will be aligned to the Module mounting holes as the Modules are installed.

5 Pre-assemble the Slide Plates

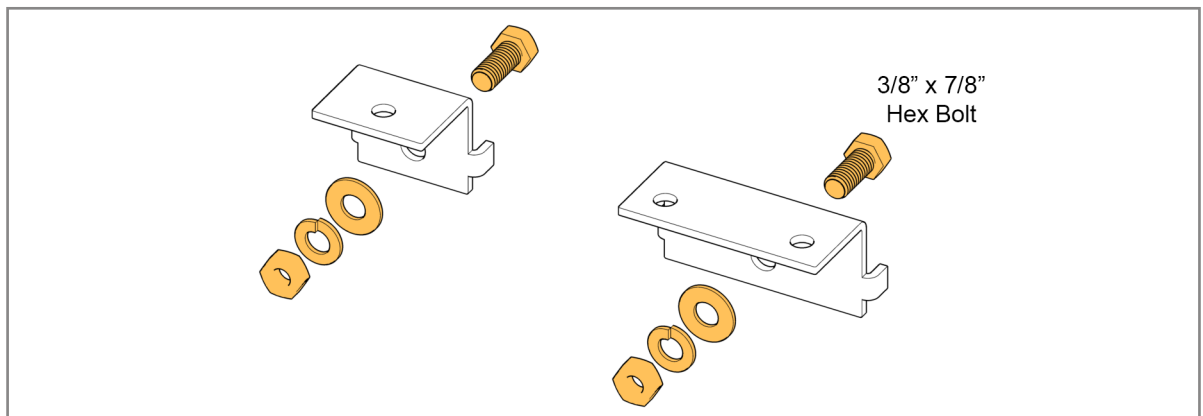

Pre-assemble each of the Slide Plates using a 3/8" x 7/8" Hex Bolt, Flat Washer, Lock Washer, and Hex Nut. Leave the hardware loose for the next step.

6 Attach Double Hole Slide Plates to Rails

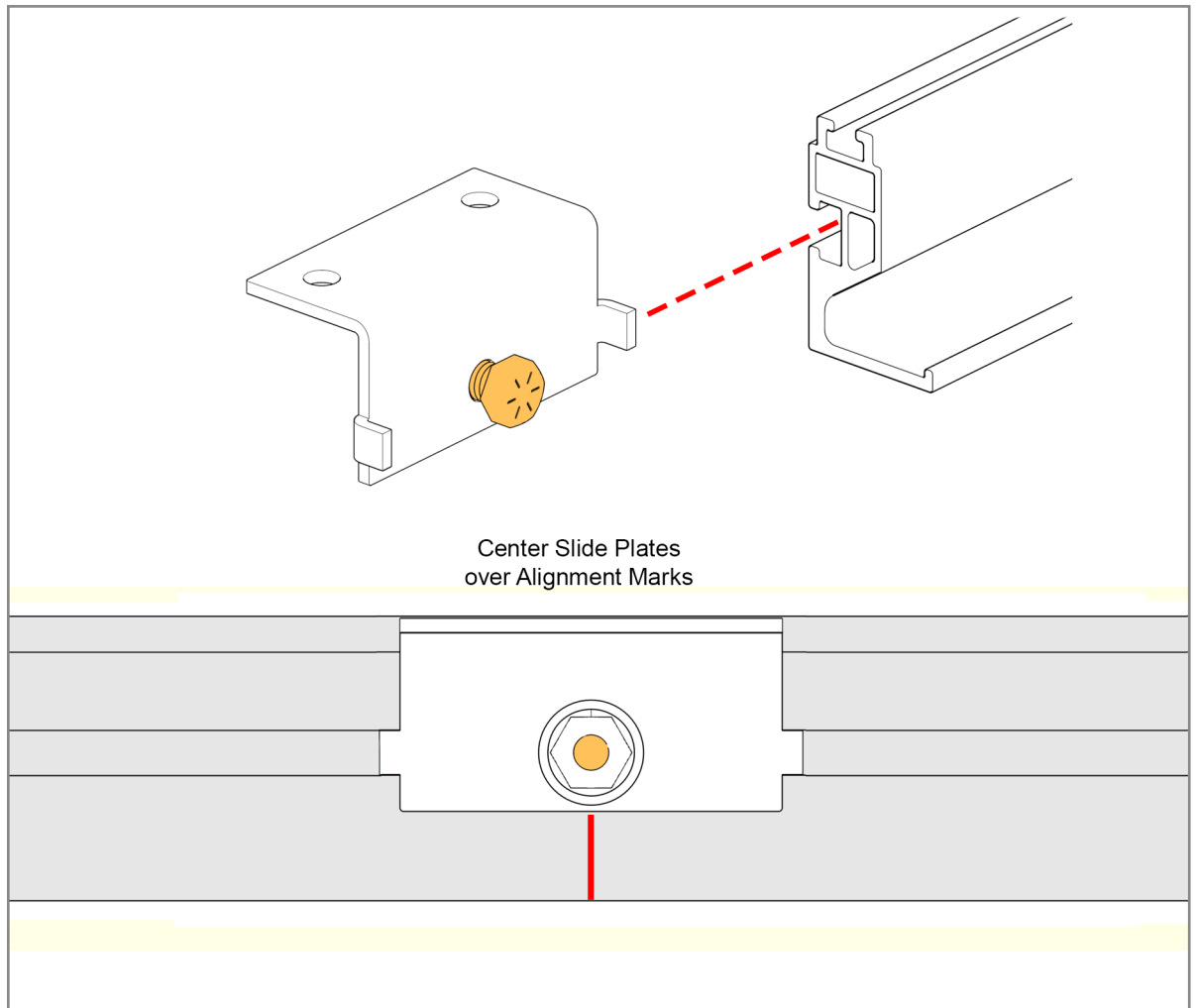

On each of the four Rails, install the Double Hole Slide Plates to be centered over the previously made mark on the Rails. Insert the head of the Hex Bolt into the Rail Channel as shown and align their centers over the marks. Tighten these four securely and **torque at 32-34 ft.-lbs.**

7 Attach Single Hole Slide Plates to Rails

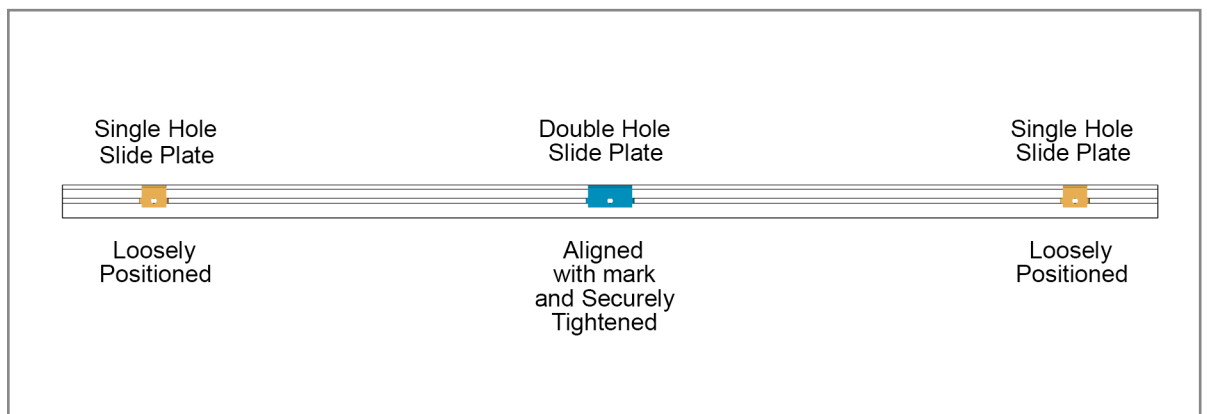

Install the two Single Hole Slide Plates in a similar manner, loosely positioning them as shown above. These do not align to any marks or measurements. They will be moved into alignment with the Module mounting holes as the Modules are installed. Hand tighten for now.

8 Install the Mounting Sleeve on Vertical Pipe

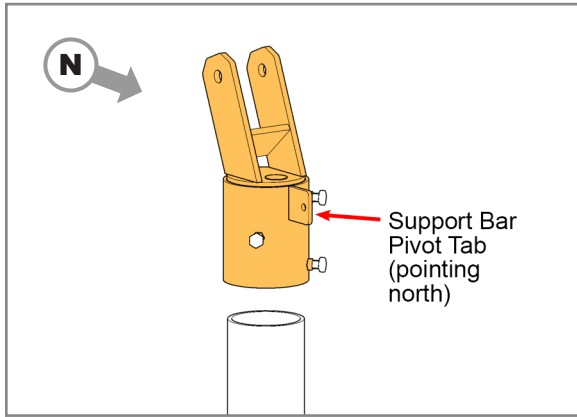

Slip the Mounting Sleeve on top of the Mounting Pole allowing it to slide down and bottom out on the Pole. Rotate the Mounting Sleeve so that the Support Bar

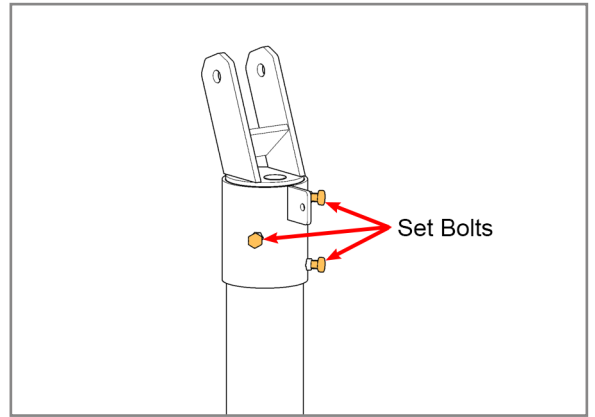

Pivot Tab is pointing north and the Strongback Vertical Towers are leaning south. Tighten Set Bolts and **torque to 32-34 ft.-lbs.**

9 Install the Strongback

CAUTION
This is a two person activity. The Strongback must be held in place by one person while the second person aligns it and secures it to the Mounting Sleeve using the Pivot Bolt and the 1/2" hardware. Failure to do so could lead to serious personal injury.

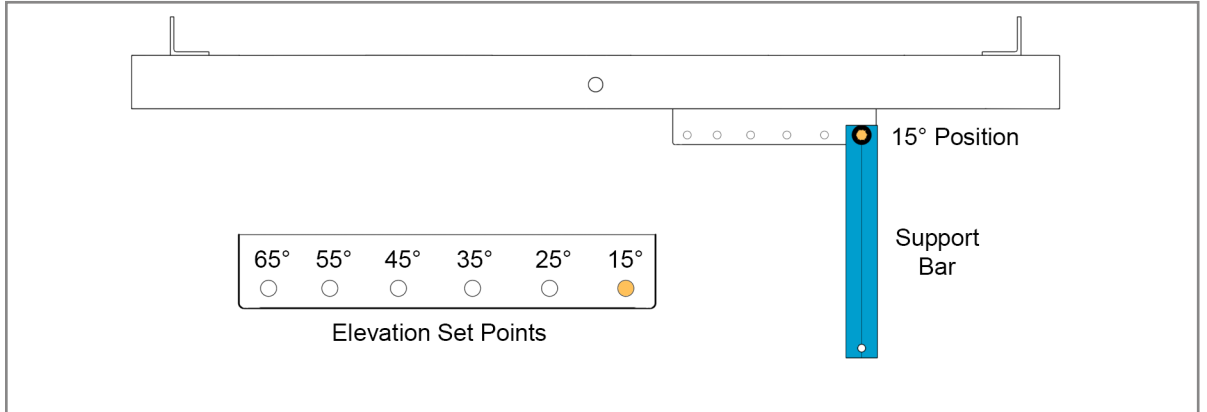

Although this system offers variable elevation set points, for ease of assembly set the angle to 15°. Optimum tilt setting of the rack will take place later in these instructions.

CAUTION
The Pivot Bolt cannot be left loose - the Mounting Sleeve Vertical Towers must be firmly clamped to the sides of the Strongback eliminating any gaps between the Vertical Towers and the Strongback. See the illustration on following page.

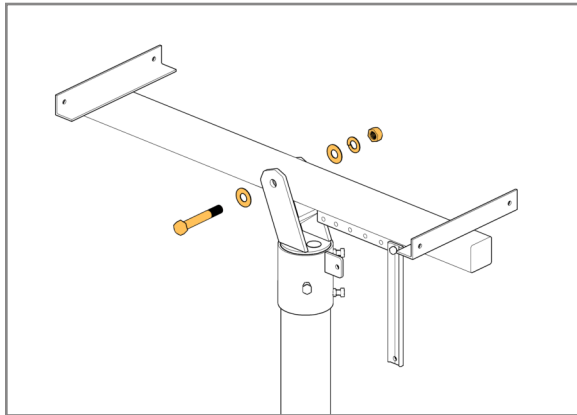

Secure Strongback to Mounting Sleeve with Pivot Bolt, two Flat Washers, Lock Washer and Nut. Secure Support Bar to Mounting Sleeve with 3/8" x 1-3/4" Bolt, two Flat Washers, Lock Washer and Nut.

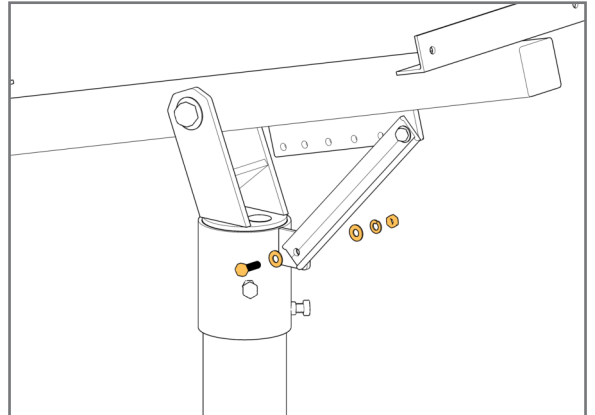

Torque Support Bar hardware to 32-34 ft.-lbs.

9 Install the Strongback (continued)

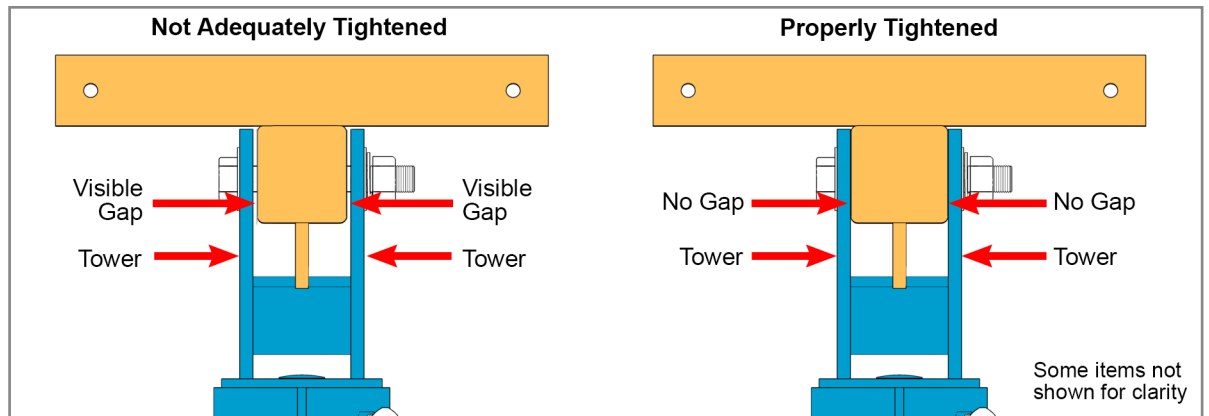

Tighten the Pivot Bolt closing any visible gaps between the Strongback and the Mounting Sleeve Towers.
Torque to 125-150 ft.-lbs.

10 Install the Cross-Bars

CAUTION

This is a two person activity. Cross-Bars are long and unstable before they are fully secured to the Strongback. Cross-Bars must be held in place by one person while the second person aligns and secures them to the Strongback. Failure to do so could lead to serious personal injury.

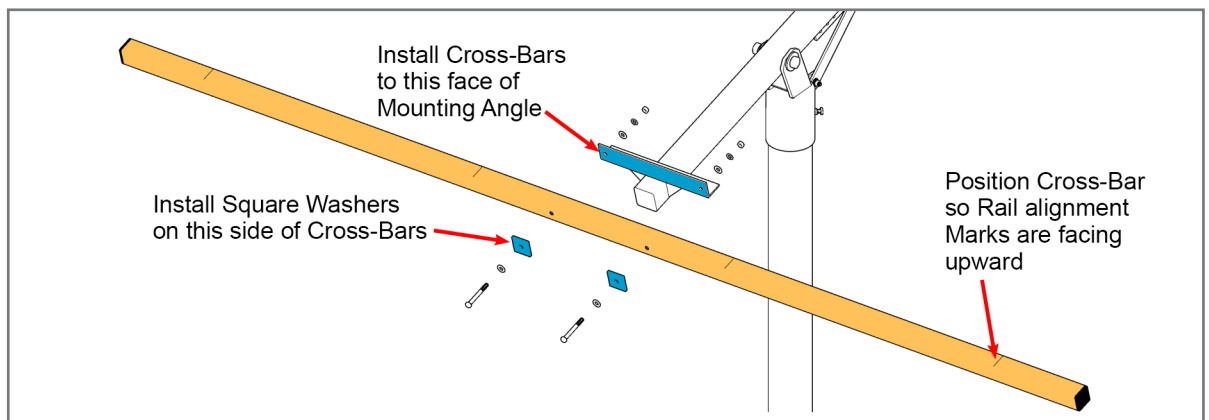

Install the two Cross-Bars with a 3/8" x 3-1/4" Hex Bolt, Square Washer, Flat Washers, Lock Washer and Hex Nut. Tighten and **torque to 30-32 ft.-lbs.**

11 Install Rails

CAUTION
 This is a two person activity. Module Rails are unstable before they are secured to the Rail Brackets.



When installing the Rails orient their profiles as shown.

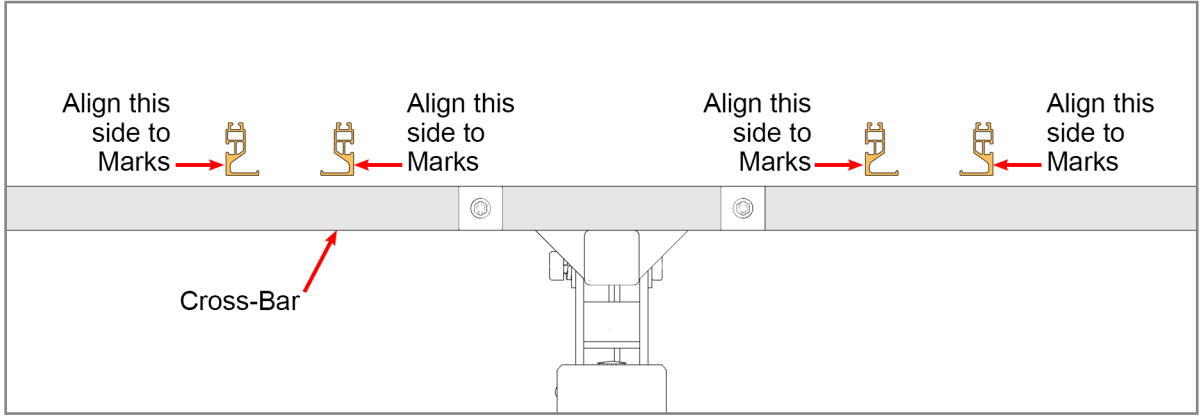

Be sure to align the correct side of the Rail with the Rail alignment marks on the Cross-Bars.

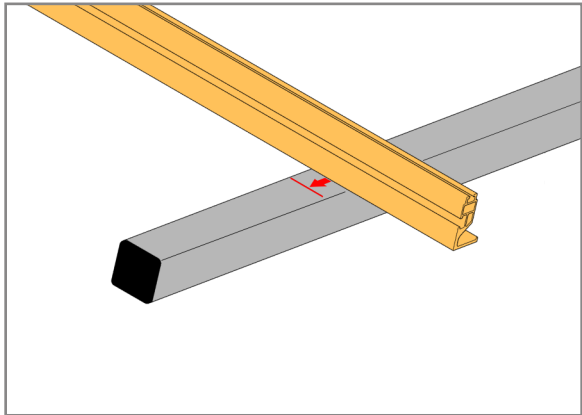

Align the Rail to the alignment marks and straddle its mounting holes over the Cross-Bar. Secure with a 3/8" x 2" x 2-5/8" U-Bolt, Flat Washers, Lock Washers and

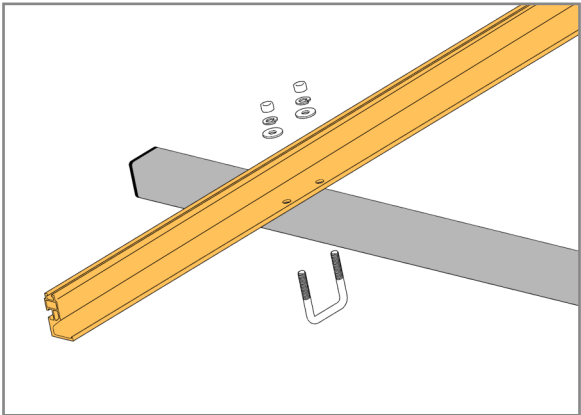

Hex Nuts at each Cross-Bar. Finger tighten for now to hold in place. Final tightening will come later.

12 Install Modules

CAUTION

This is a two person activity. Modules are heavy and unstable before they are fully secured to the Module Rails. PV Modules must be held in place by one person while the second person aligns and secures them to the Module Rails. Failure to do so could lead to serious personal injury and damaged components.

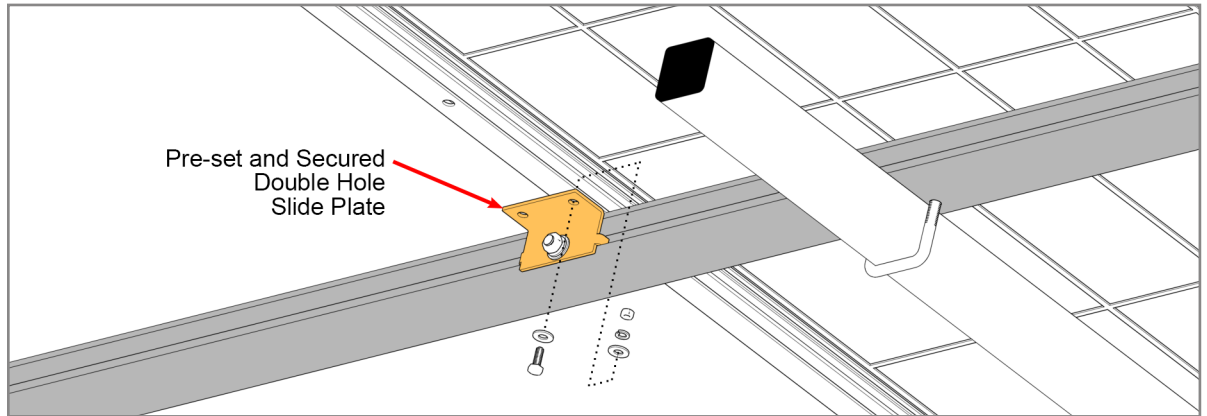

Align Module Mounting Holes with the installed Double Hole Slide Plates and secure Module with 1/4" x 3/4" Hex Bolt, Flat Washers, Lock Washer and Hex Nut. Finger tighten for now. Repeat on opposite Rail.

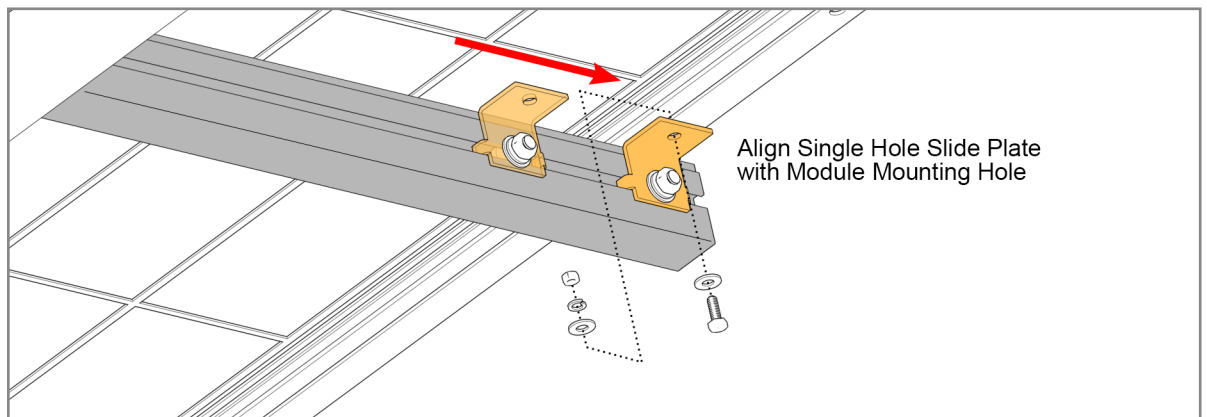

Loosen Single Hole Slide Plates and align with Module Mounting Hole. Secure Module with 1/4" x 3/4" Hex Bolt, Flat Washers, Lock Washer and Hex Nut. Finger tighten for now. Repeat on opposite Rail. Continue in this manner and install the remaining Modules.

13 Square and Align the Array. Return and Tighten Mounting Hardware

CAUTION

Be certain to re-tighten all Module Rail and PV Module mounting hardware and torque to the specified values. Failure to do so could lead to structural failure, damaged components and/or serious personal injury.

Using a square and visual references, ensure that the array is aligned to the mounting structure. Confirm that the PV Modules are square and have consistent even spaces all around. Adjust if necessary.

Tighten Mounting Hardware

- A. Return and tighten each set of the 3/8" U-bolts, securing the Module Rails to the Cross-Bars. **Torque all to 32-34 ft.-lbs.**
- B. Return and tighten each of the 3/8" hardware securing all of the Slide Clamps (Single and Double Hole) to the Module Rails. **Torque all to 32-34 ft.-lbs.**
- C. Return and tighten each set of 1/4" mounting hardware, securing the PV Modules to the Slide Clamps. **Torque all to 6-8 ft.-lbs.**

14 Adjust the Array Tilt Angle

WARNING

Do not attempt to remove the Pivot Bolt during tilt adjustments! Removal could lead to serious personal injury or death. Adjustments are made with the Pivot Bolt hardware loosened but in place.

CAUTION

This is a two person activity. As the hardware is loosened, the rack is heavy and unstable. The rack must be held in place by one person while the second person loosens the hardware and then re-installs and tightens the hardware back in place. Failure to do so could lead to serious personal injury and damaged components.

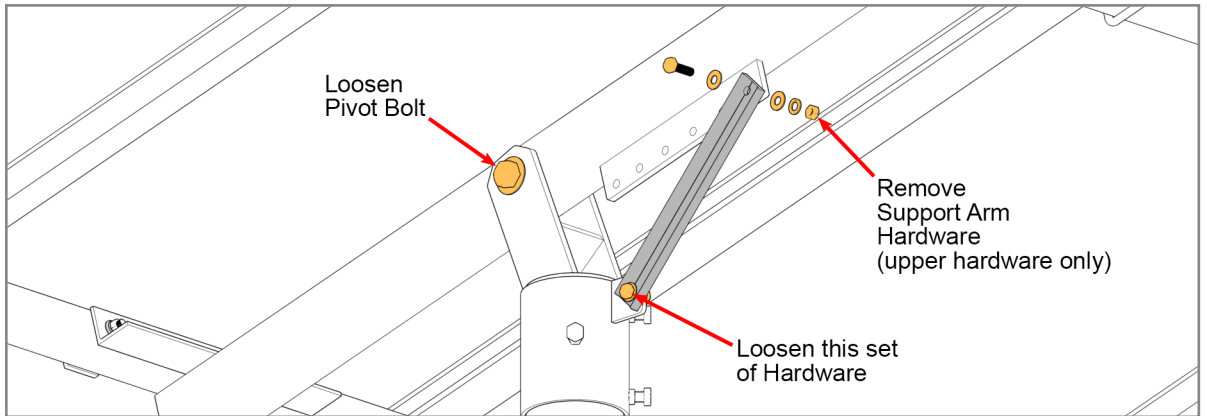

A. While one person holds the south edge of rack, the other loosens the Pivot Bolt and the hardware securing the lower end of the Support Arm Hardware.

Now remove the upper 3/8" hardware attaching the Support Bar to the Strongback.

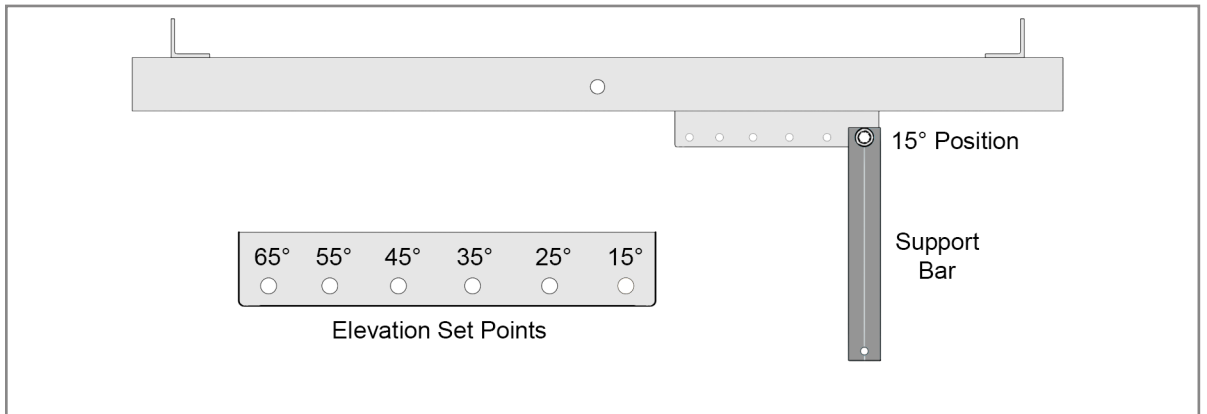

B. Tilt the rack to the desired elevation angle (15°, 25°, 35°, 45°, 55° or 65°) and reinstall the 3/8" hardware securing the Support Bar to the Strong-

back. Tighten hardware (at both ends of Support Bar) and **Torque to 32-34 ft.-lbs.**

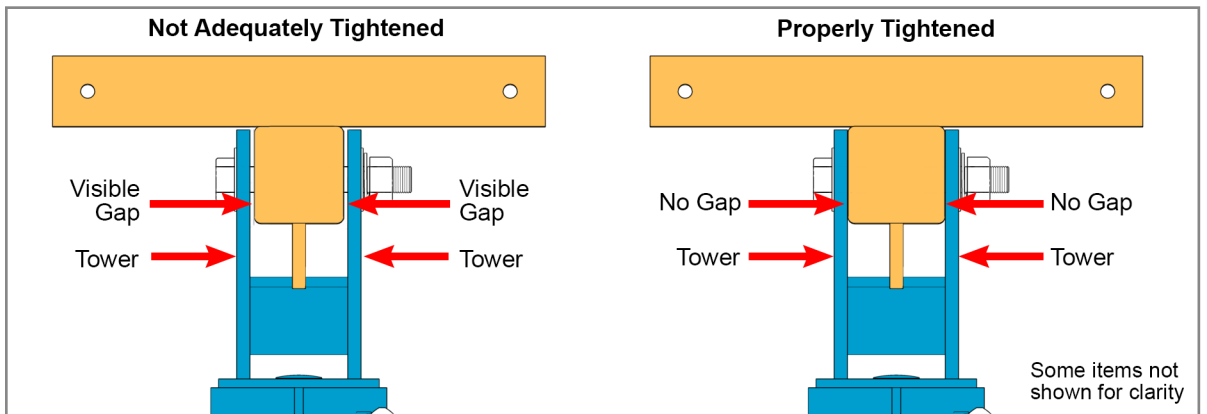

C. Re-tighten the Pivot Bolt. The Pivot Bolt cannot be left loose - the Mounting Sleeve Vertical Towers must be firmly clamped to the sides of the Strongback eliminating any gaps between the Vertical

Towers and the Strongback. **Torque to 125-150 ft.-lbs.**



PREFORMED LINE PRODUCTS

Albuquerque Office
1700 Louisiana Blvd., Suite 130
Albuquerque, NM 87110

Corporate Headquarters
660 Beta Drive
Mayfield Village, OH 44143

Telephone: 800.260.3792
Fax: 505.889.3548
www.preformed.com
E-mail: info@plpsolar.com