

## **POWER PEAK™ AL**

### **ASSEMBLY INSTRUCTIONS**

**step-by-step  
assembly and installation**

## Power Peak™ AL Ratings

The Power Peak™ AL conforms to ANSI/UL UL2703 (2015) Standard for Safety First Edition: Mounting Systems, Mounting Devices, Clamping/Retention Devices, and Ground Lugs for Use with Flat-Plate Photovoltaic Modules and Panels.

### Electrical

Note: Electrical installations must be in accordance with the National Electric Code ANSI / NFPA 70. Contact your local Authorities Having Jurisdiction (AHJ) for additional details.

Max Overcurrent Protective Device (OCPD) Rating: 25A

Equipment Grounding Conductor Sizing

Module Fuse Rating	Copper Wire Size
<15 AMPS	#14 AWG 90°C
<20 AMPS	#12 AWG 90°C
20-60 AMPS	#10 AWG 90°C

### Splice Plates

Slice Plates have been tested per UL2703 Bonding & Grounding requirements without the use of Bonding Jumpers.

See assembly procedures for proper assembly.

### Module Clamps

Module clamps have integrated grounding and have been tested to UL 2703

See Module Compatibility List for list of approved modules.

Module Orientation: Portrait

### Structural Certification

Mechanical Load Rating: Designed and Certified for Compliance with IBC & ASCE/SEI-7 through separate PE reviews.

### Marking

Product markings identified per UL2703 are to be located in a location that is readily accessible for inspection.

### Periodic Inspection

Periodic re-inspection is a recommended system maintenance procedure to check for loose components or corrosion. If any loose components and/or corrosion is found, the affected components are required to be replaced immediately, with the original mounting system manufacturer's component parts.

## Power Peak AL

### WARNING

Follow the procedures and precautions in these instructions carefully.

### About the product

The Power Peak AL is designed to mount on standard I-Beams which are commonly pile driven directly into the soil to reduce ground work and associated labor cost. The Power Peak is designed per specific site conditions and arrives on site with fewer preassembled components for a simpler and faster assembly. In the design phase, the entire array is selectively broken down into individual structures. Each individual Power Peak structure mounts the modules two rows in portrait where the number of modules in each row matches the specified string size for easier wiring and reduction in materials. The Power Peak mounting system also features the RAD™ Lock-in-Place clamping system for a fast and secure installation.

I-Beam size and foundation requirements are based on several factors including the array surface area, maximum design wind speed, exposure category, snow loading, tilt angle, soil type and front edge clearance.

### Pre-Configured Components

For ease of assembly and to address the wide range of modules available, the Power Peak ships pre-configured to meet job specific requirements. The positions of several components have been strategically placed on the Strongback to meet the dimensional requirements of the PV Modules in use while also positioning the Strongback Assembly (in the N-S direction) on the mounting post.

For foundation and I-Beam recommendations on a specific installation, please:

Contact us by Phone: 800-260-3792

Send an Email request: [info@plpsolar.com](mailto:info@plpsolar.com)

### About these instructions:

- They include information on assembling the product and are intended to be used by individuals with sufficient technical skills for the task. Knowledge and use of hand tools, measuring devices and torque values is also required.
- They include various Notes, Cautions, and Warnings that are intended to draw your attention and assist in the assembly process and/or to draw attention to the fact that certain assembly steps may be dangerous and could cause serious physical injury and/or damage to components. Follow the procedures and precautions in these instructions carefully.

### Required Tools

- 1/2 inch wrench or socket for 5/16 inch module clamp hardware
- 15/16 inch wrench or socket for 5/8 inch hardware
- Torque wrench
- Ratchet wrench
- Ratchet extension bar
- String
- Framing Square
- Tape Measure
- Inclinator

### WARNING

STAINLESS STEEL HARDWARE CAN GALL WHEN TIGHTENED TOO QUICKLY. INSTALLER SHOULD USE A SILVER GRADE ANTI-SEIZE COMPOUND PRIOR TO ASSEMBLING ANY STAINLESS STEEL HARDWARE. DO NOT USE AN IMPACT DRIVER. ALL OTHER DRIVER TYPES SHOULD BE SET TO LOW SPEED SETTINGS.

## Power Peak AL Main Components

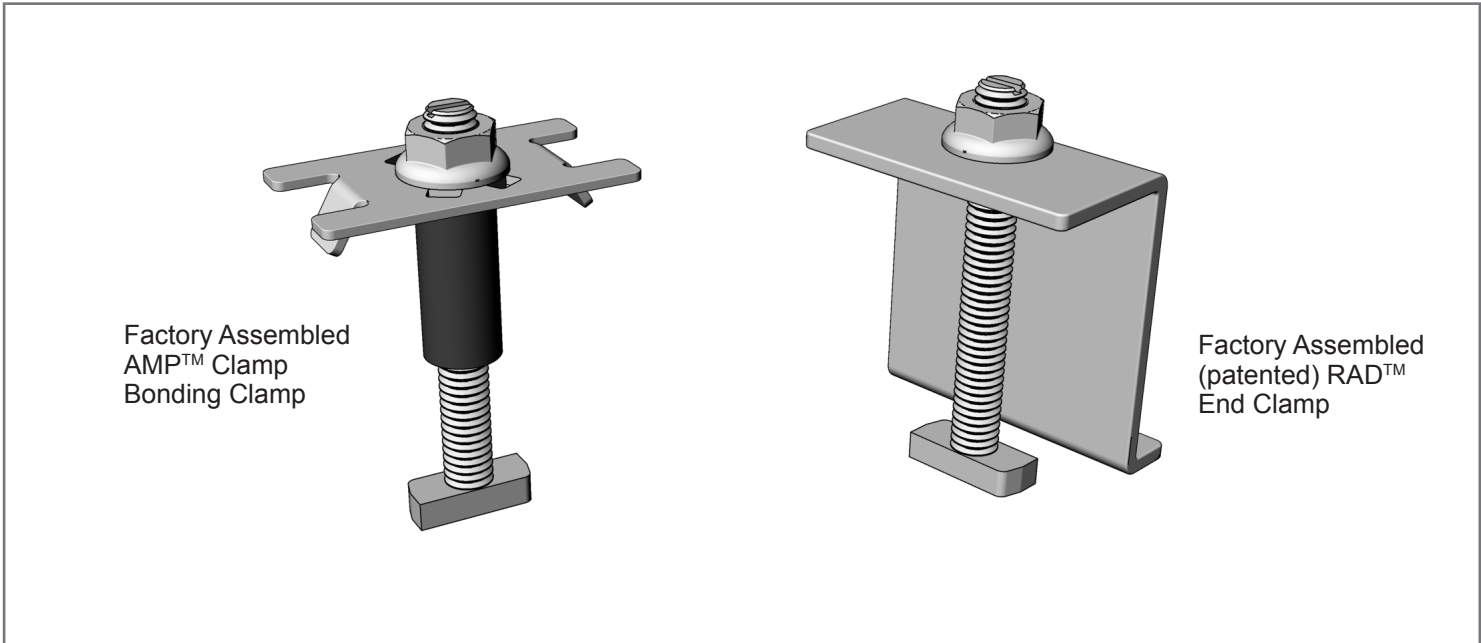
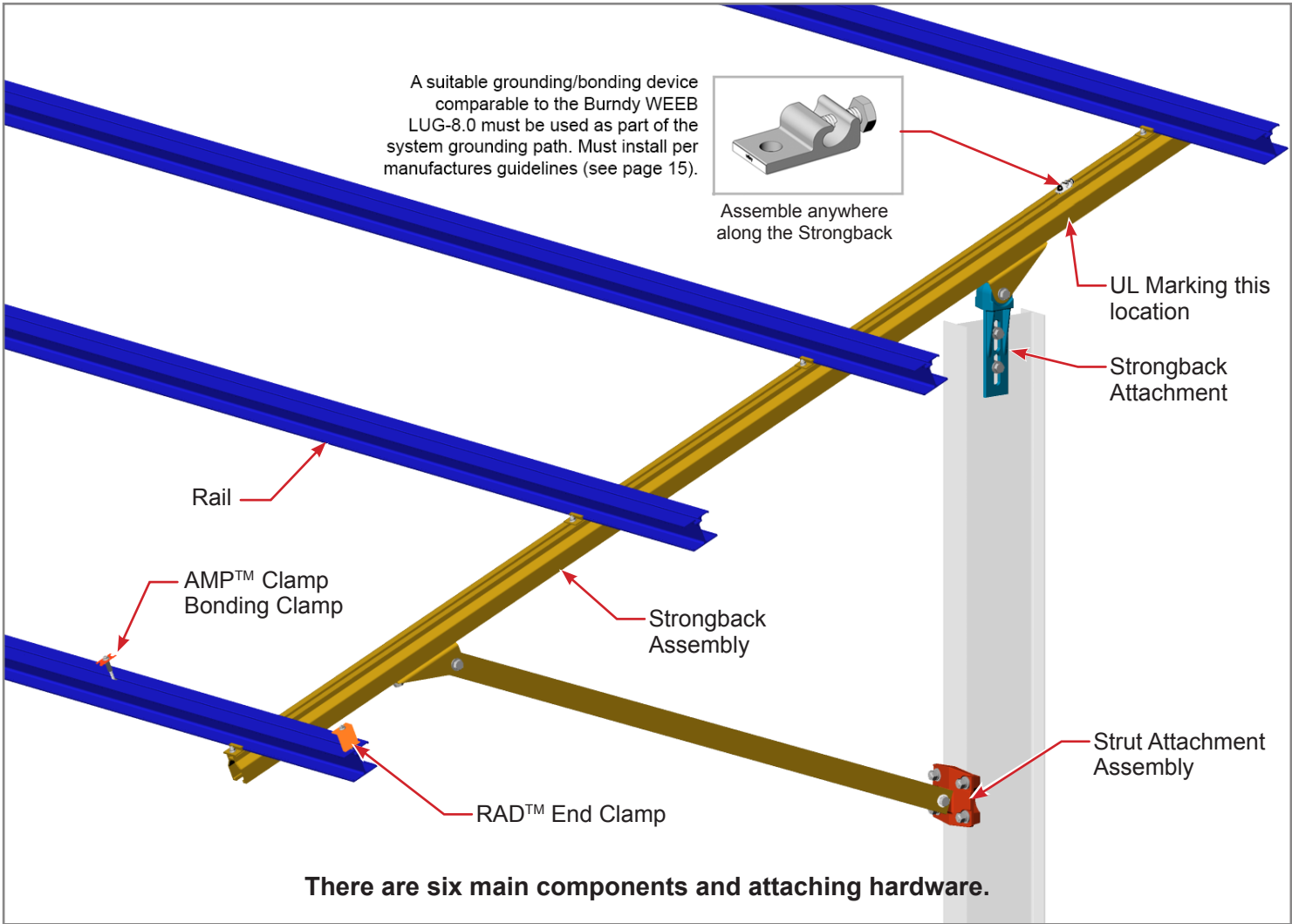

**Power Peak AL Parts Identification**

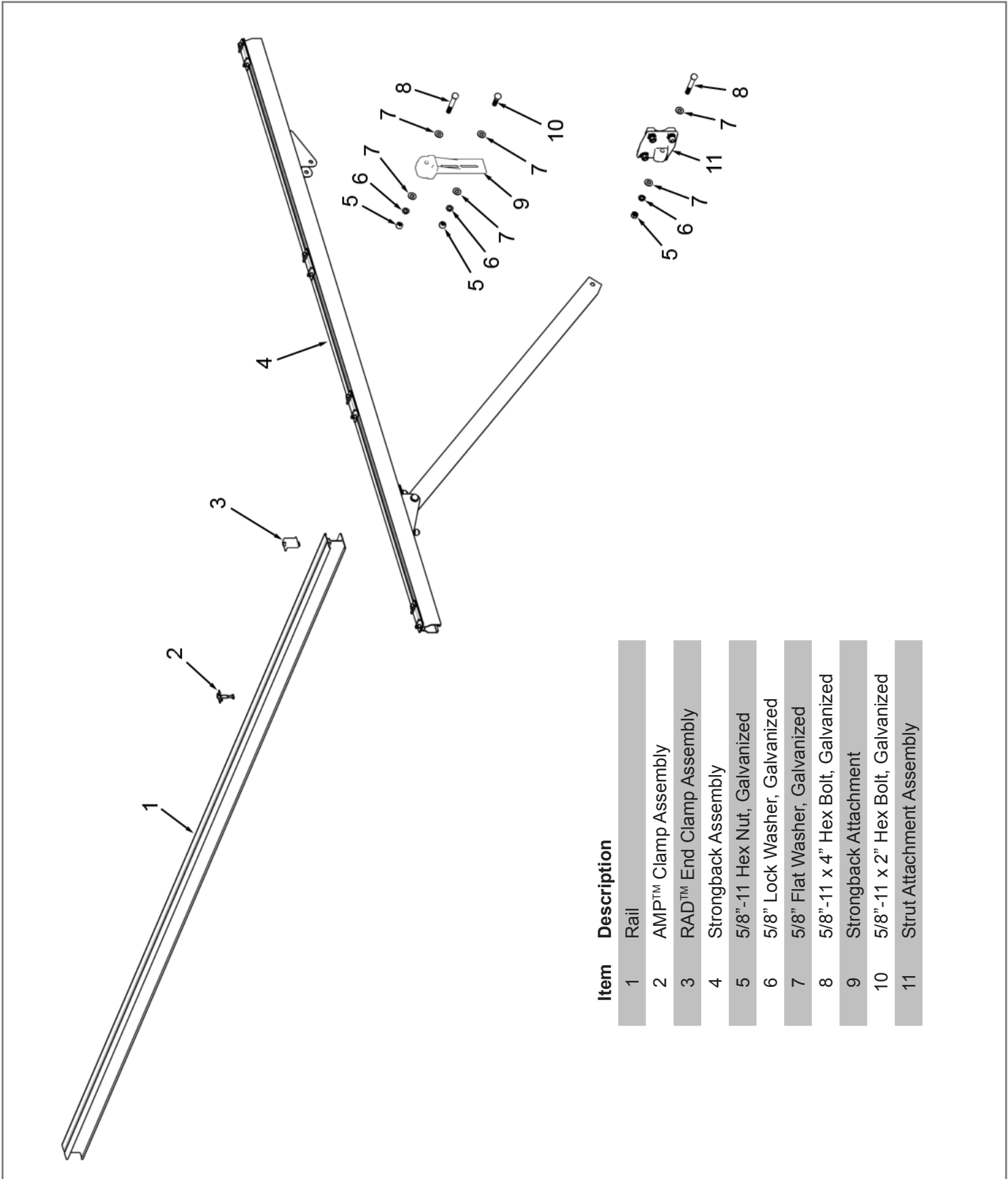

Item	Description
1	Rail
2	AMP™ Clamp Assembly
3	RAD™ End Clamp Assembly
4	Strongback Assembly
5	5/8"-11 Hex Nut, Galvanized
6	5/8" Lock Washer, Galvanized
7	5/8" Flat Washer, Galvanized
8	5/8"-11 x 4" Hex Bolt, Galvanized
9	Strongback Attachment
10	5/8"-11 x 2" Hex Bolt, Galvanized
11	Strut Attachment Assembly

## 1 Set I-Beam Posts

Using a preferred method, drive/set the I-beams per the project specifications while keeping the relative height tolerance to each other at  $\pm 1/4"$ .

## 2 Install the Strongback Attachment to the I-Beam

### NOTE

Strongback Attachments must be consistently installed on the same side of the I-Beam (all on the east side or all on the west side of the I-Beam).

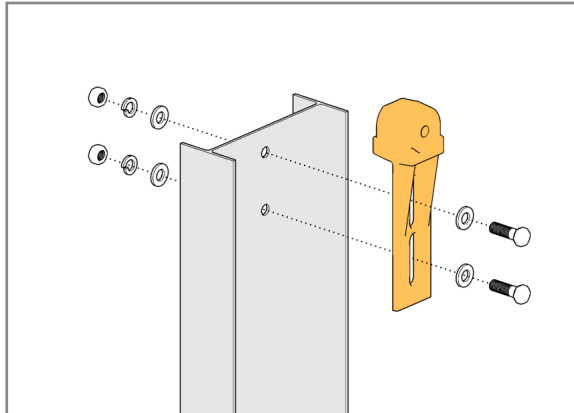

Install the Strongback Attachments with 5/8"-11 x 2" Hex Bolt, Flat Washers, Lock Washer and Hex Nut. Allow the slots of the Strongback Attachment to come

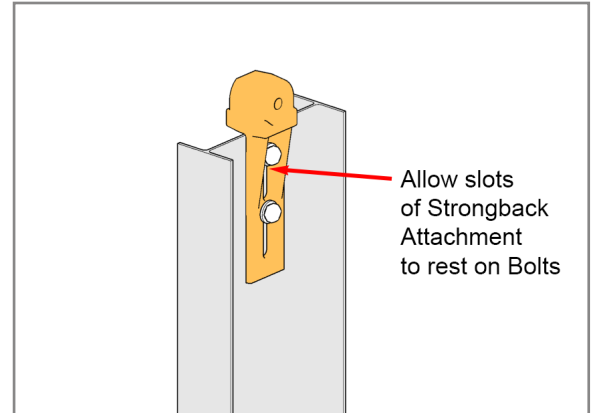

to rest on the Bolts. **Hand tighten for now.**

## 3 Install the Strut Attachment Assembly on the I-Beam

### NOTE

The vertical position of the Strut Attachment on the I-Beam determines the tilt angle of the array and therefore its position must be measured and marked on each of the vertical I-Beams. Reference the site specific drawings for placement.

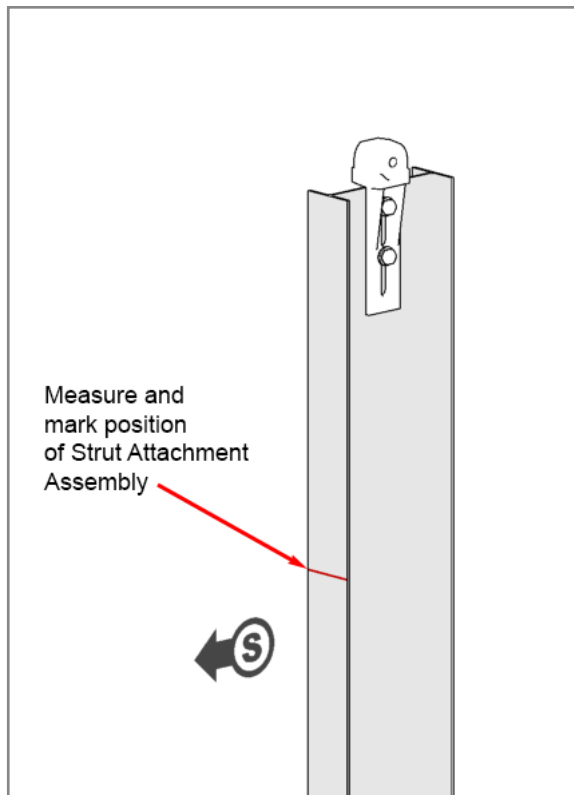

Mount Strut Attachment on south flange of I-Beam. Straddle the clamps of the Strut Attachment on flange of I-Beam and slide the Strut Attachment downward

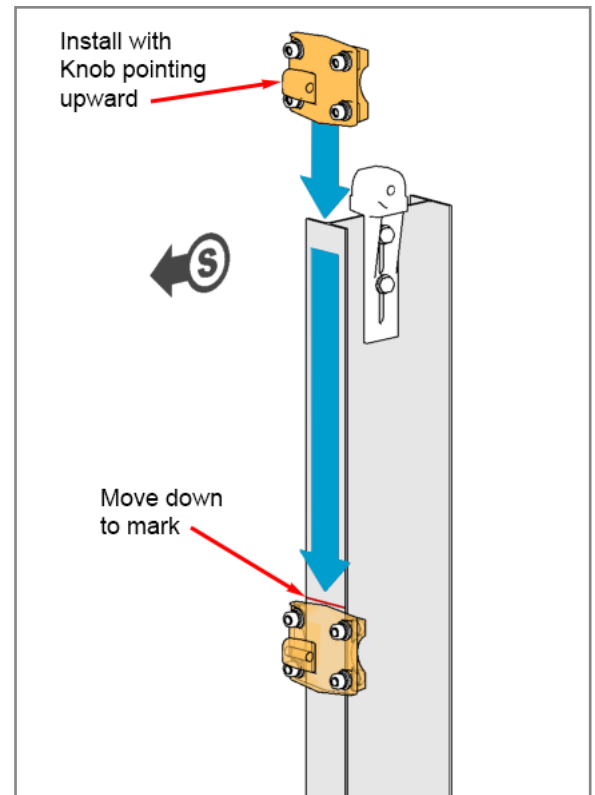

aligning it to the previously made Mark on I-Beam. **Hand tighten for now.**

## 4 Install the Strongback Assembly

**CAUTION**  
This is a two person activity. While one person holds the Strongback Pre-Assembly in place, the second person aligns its attachment points and secures it with the required hardware.

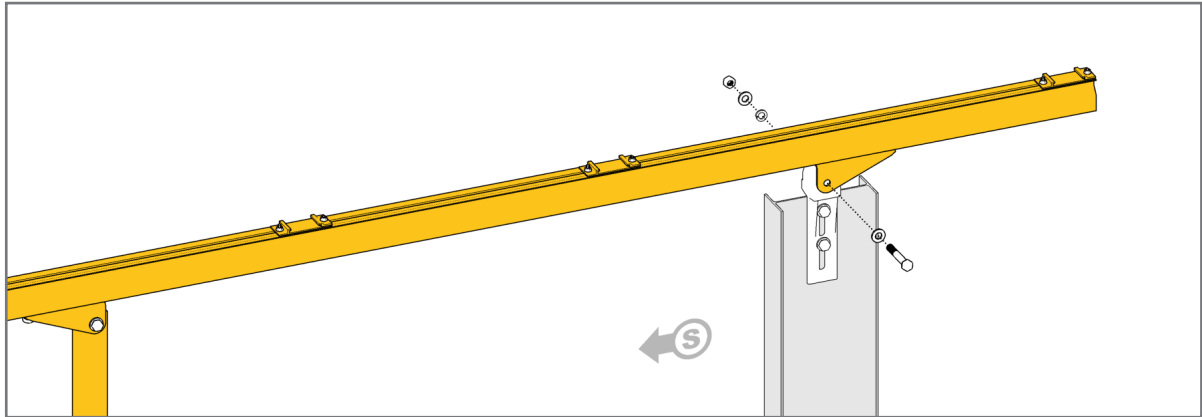

Install the Strongback onto the Strongback Attachment with 5/8"-11 x 4" Hex Bolt, Flat Washers, Lock Washer and Hex Nut. **Hand tighten for now.**

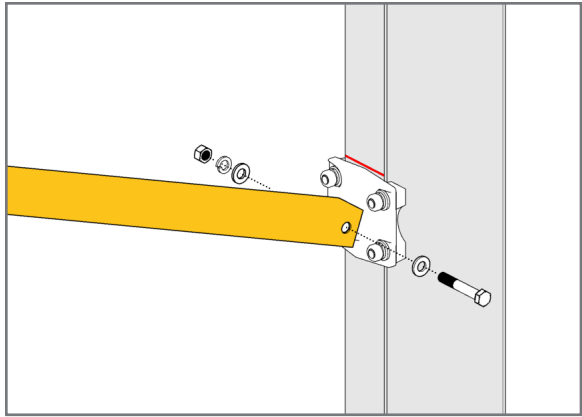

Install the Strut to the Strut Attachment with 5/8"-11 x 4" Hex Bolt, Flat Washers, Lock Washer and Hex Nut. **Hand tighten for now.**

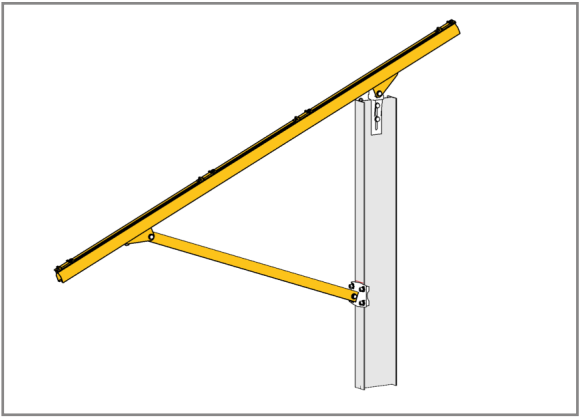



## 5 Align the Rail Base Surfaces via the Strongbacks

**NOTE**  
It's very important to align the Rail Base surfaces to within 1/8" of each other before installing the Rails.

- A. Pull a string on top of and between the east and west most Strongbacks. Align the string with the center of the I-beam.
- B. On those Strongbacks that need adjustment, loosen and slide the Strongback Attachment up or down the I-beam to bring the Strongback within 1/8" of the string.
- C. To adjust the N-S alignment of the Rail Bases, loosen the Strongback Slide Attachment and slide the Strongback in the appropriate direction to align the Rail Bases. Torque to 85 ft.-lbs.
- D. Tighten the Strongback Attachments securely to the I-beam. **Torque to 85-90 ft.-lbs.**

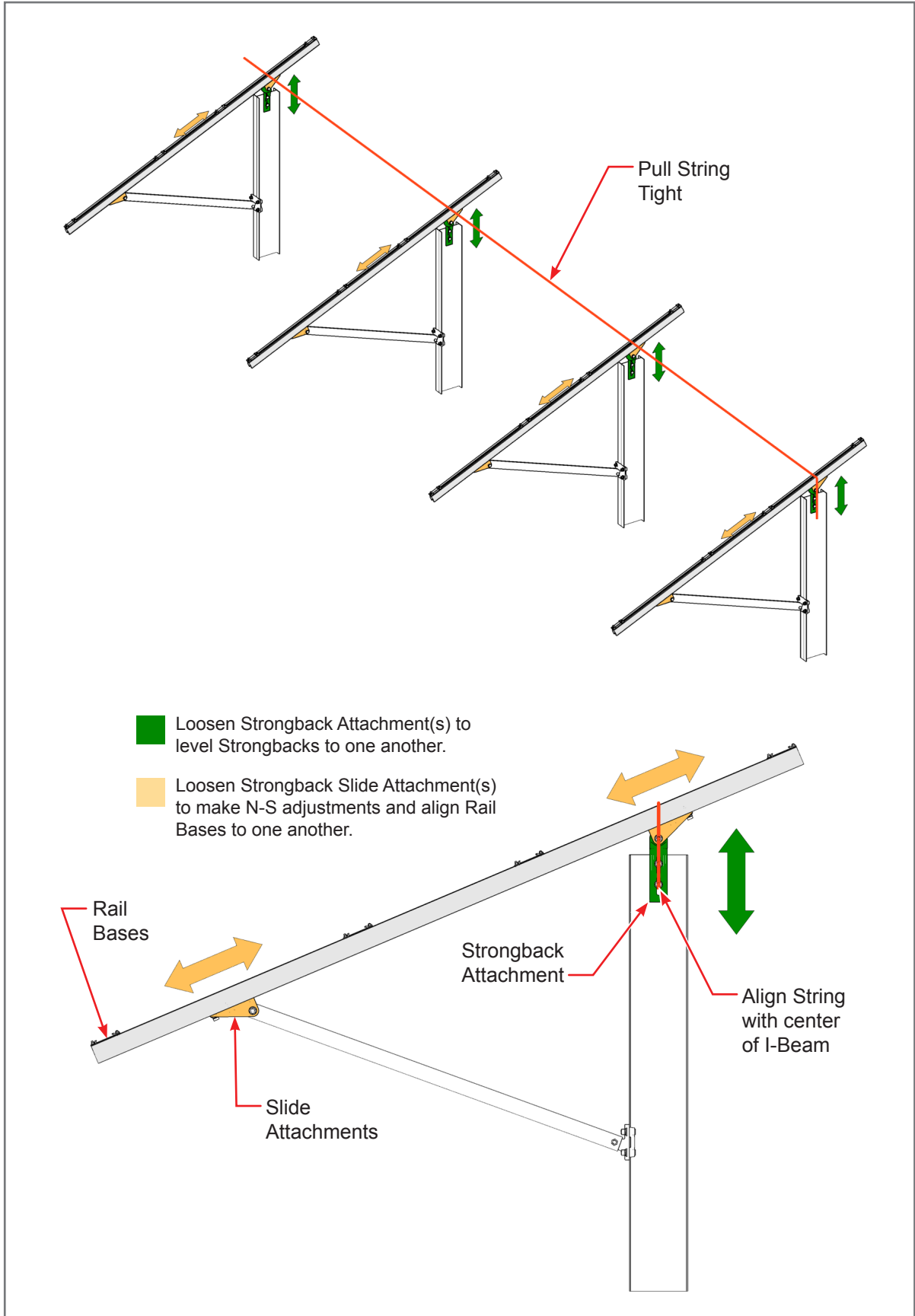



## 6 Verify/Set the Final Tilt Angle

### CAUTION

This is a two person activity. During the tilt adjustment, one person must hold the southern end of the Strongback while a second loosens the hardware and then re-tightens the hardware after the desired tilt has been achieved.

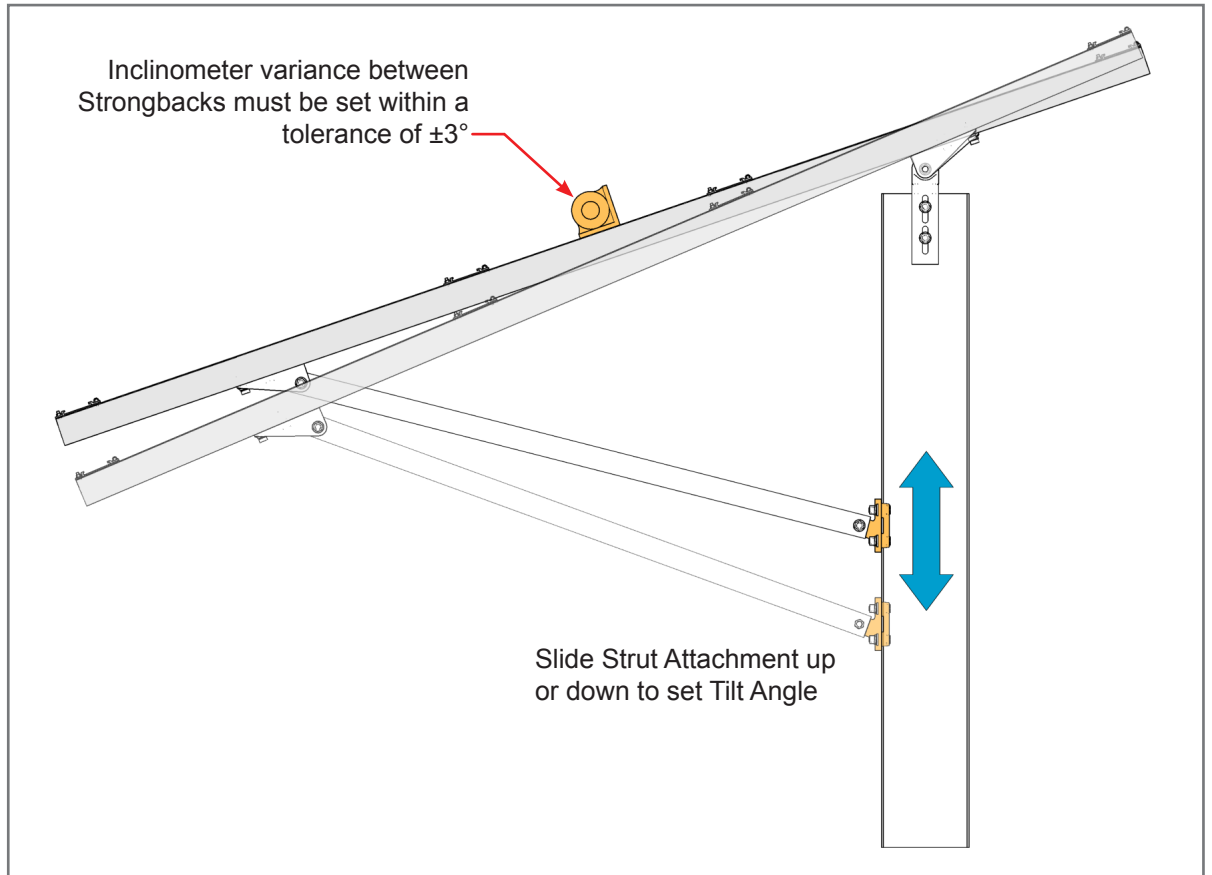

- A. Place the inclinometer on the Strongback.
- B. Loosen the hardware securing the Strut Attachment to the I-beam.
- C. Slide the Strut Attachment up or down the I-beam to bring the tilt to the desired angle.
- D. Re-tighten the hardware securing the Strut Attachment to the I-beam. **Torque to 85-90 ft.-lbs.**

## 7 Secure the Southern Strap Plate & Slide Attachment (not on all systems)

### NOTE

Step 7 only applies to systems requiring Strap Plates. If Strap Plates are required they will be found on each of the two Slide Attachments on the bottom side of the Strongback. If Strap Plates were not included with the Strongback assembly then they are not required. Skip this step and go to Step 8.

### CAUTION

For shipping purposes, the southern Strap Plate is only partially attached to the Strongback. Additional hardware must be repositioned and properly tightened to complete its installation and fully secure it to the Strongback.

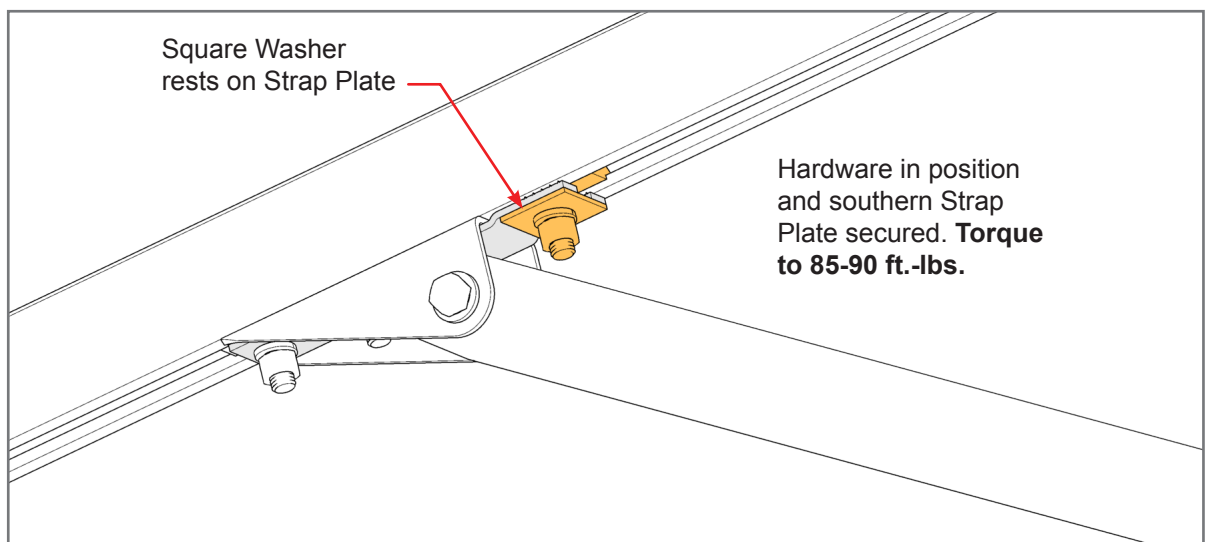
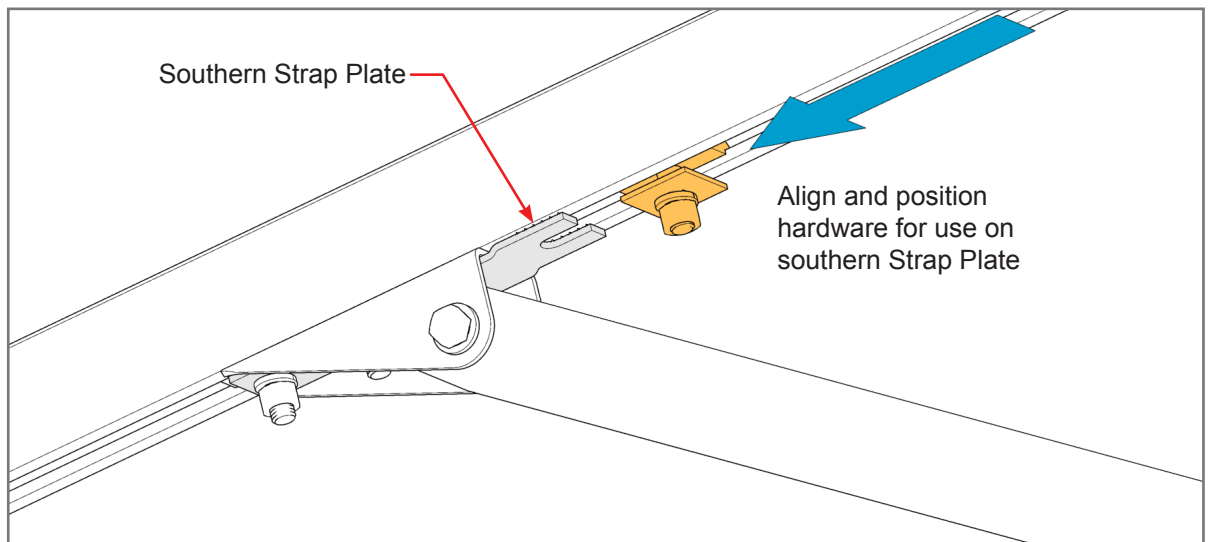
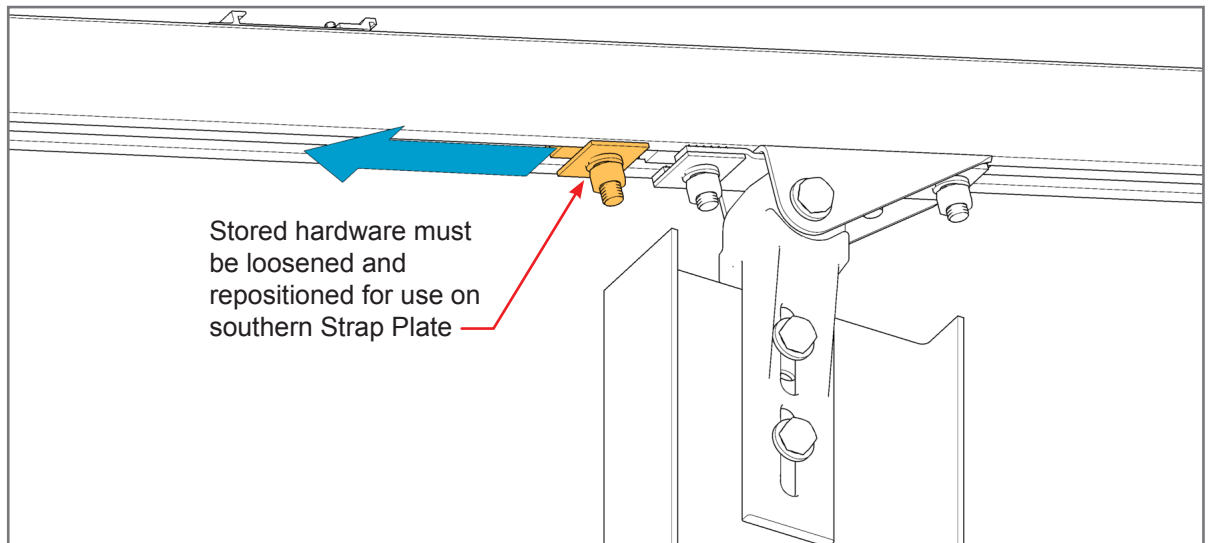

## 8 Install the Rails

### CAUTION

This is a two person activity. Each person must hold an end of the Rail while placing it onto each Rail Base of the Strongback. One person should continue to hold the Rail in place while the second person secures it with the Rail Clamp.

### NOTE

The location of the Rail Bases are preset at the factory. If alignment with the Rails is a problem, simply slide the Rail Bases along the Strongback's to align with the Rails.

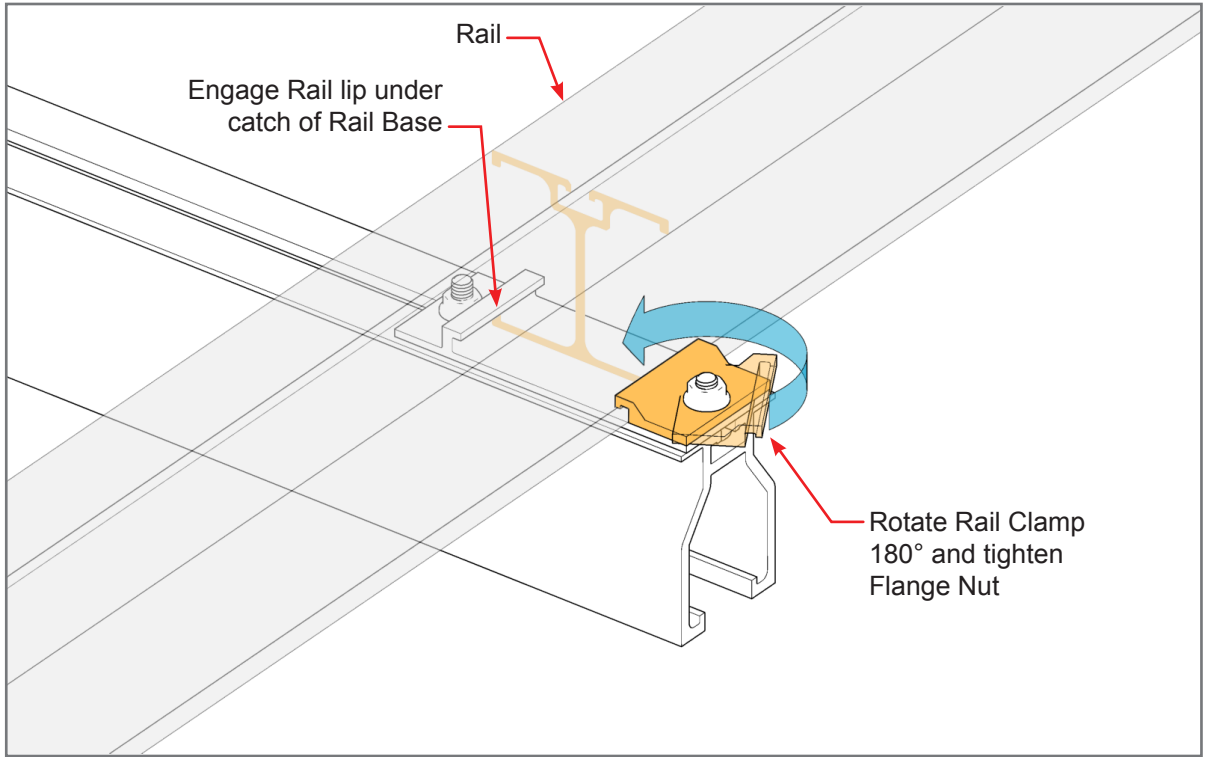

The Rails are secured via the pre-assembled clamping system (Rail Base & Rail Clamp) which are attached to the Strongbacks. Cantilever distance between the outermost Strongback and the Rail end must be set per specifications.

### NOTE

If Splice Plates are installed prior to Rail installation, the installation must be a three person activity, taking care not to damage Splice Plates during Rail installation.

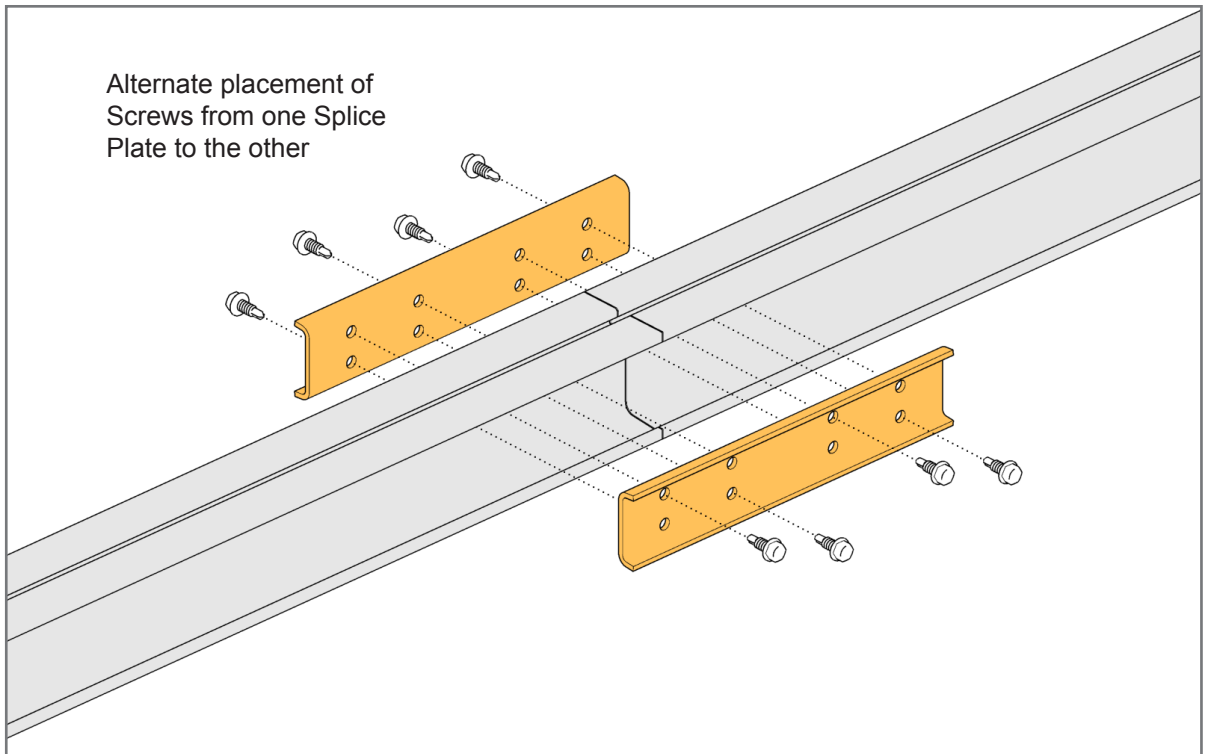

If necessary, Rails are spliced using a Splice Plate and self tapping hardware. Splicing can be done either before or after the Rails are installed on the Strongbacks. Install the Splice Plates with 1/4" x 3/4" self drilling screws. **Torque to 8 ft.-lbs.**

## 9 Square the Rack

Adjustments can be easily made to compensate for misaligned I-beams or other issues. Adjustments also provides squaring of the Rails to the Strongbacks.

During the squaring and alignment process, the main adjustment feature is the east/west articulation of the Strongback via the Strongback and Strut Attachments. Originating from the Strongback Attachment, the Strongback will pivot up to 5° to the east or west. This movement is used to square the Strongbacks to the Rails.

The design of the Strongback and Strut Attachments allows the Strongback to pivot 5° in both directions to facilitate alignment of the Strongbacks to Rails while also compensating for misaligned I-beams.

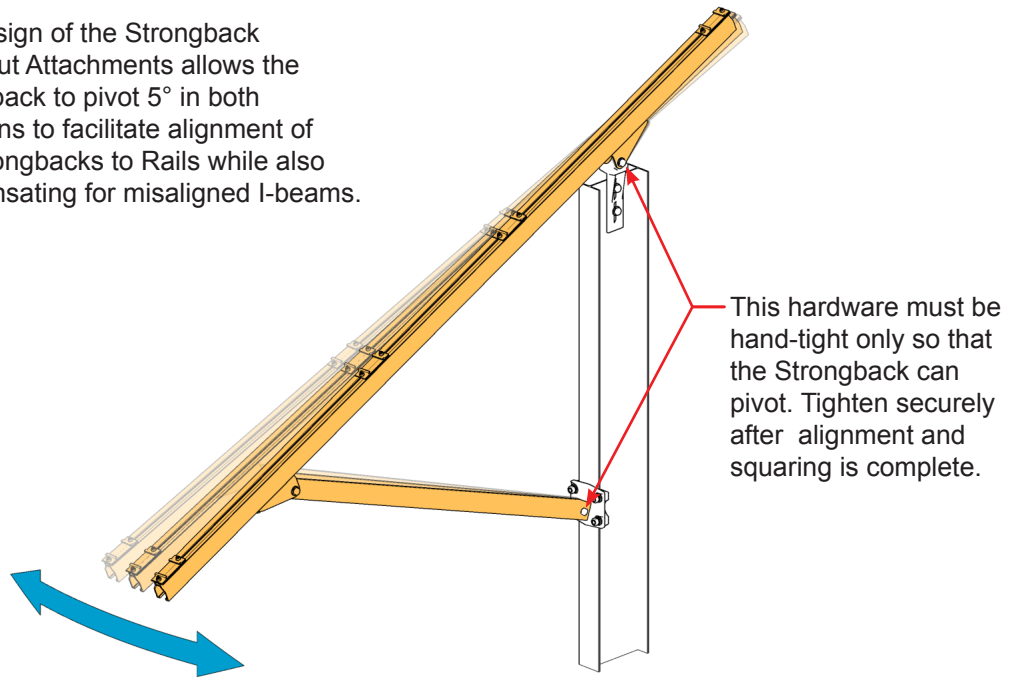

## 10 Tighten and Torque the Hardware

### CAUTION

Exceeding torque values can result in damage to components and/or Hardware.

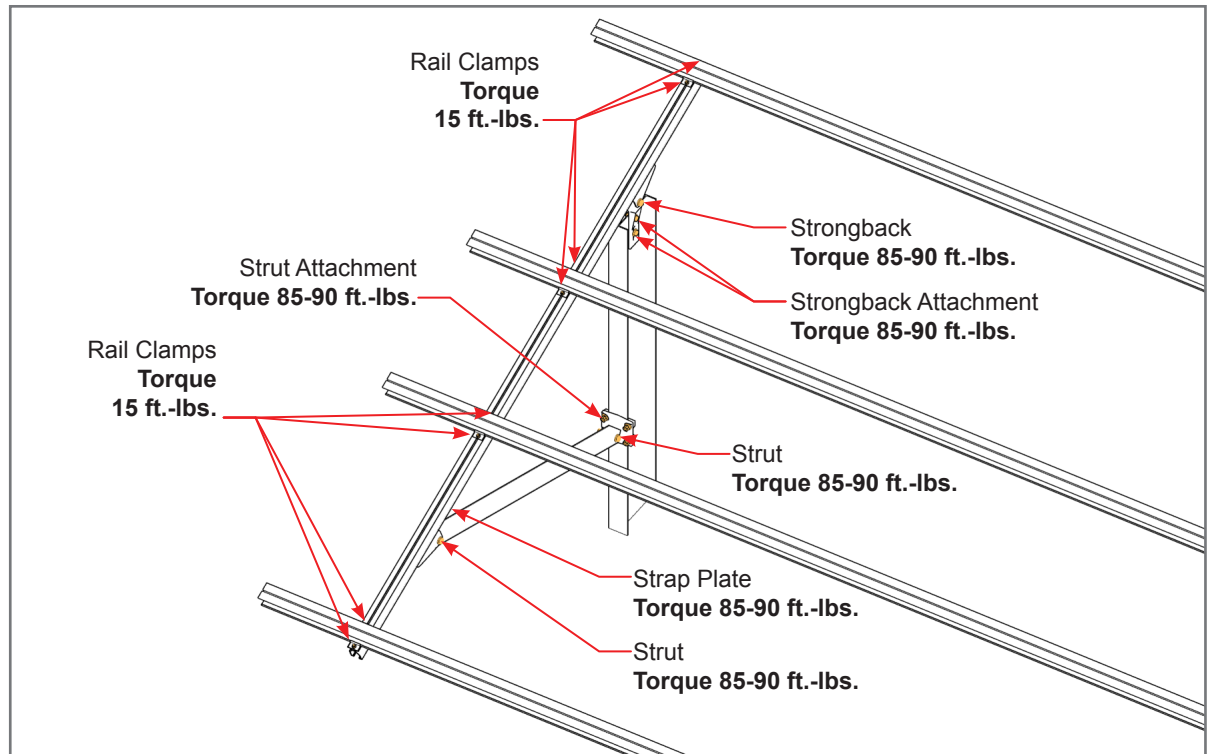

It's extremely important to tighten and torque all hardware as specified above.

## 11 Install the Modules

### CAUTION

This is a two person activity. In addition to the difficulties associated with working on a sloped rack, PV Modules are heavy. One person should hold and align the modules while a second person secures modules with clamping hardware. Failure to do so could lead to serious personal injury and/or damaged components.

### CAUTION

Module Clamps must be correctly installed. Failure to follow the correct method could lead to personal injury, structural failure, and/or damaged components.

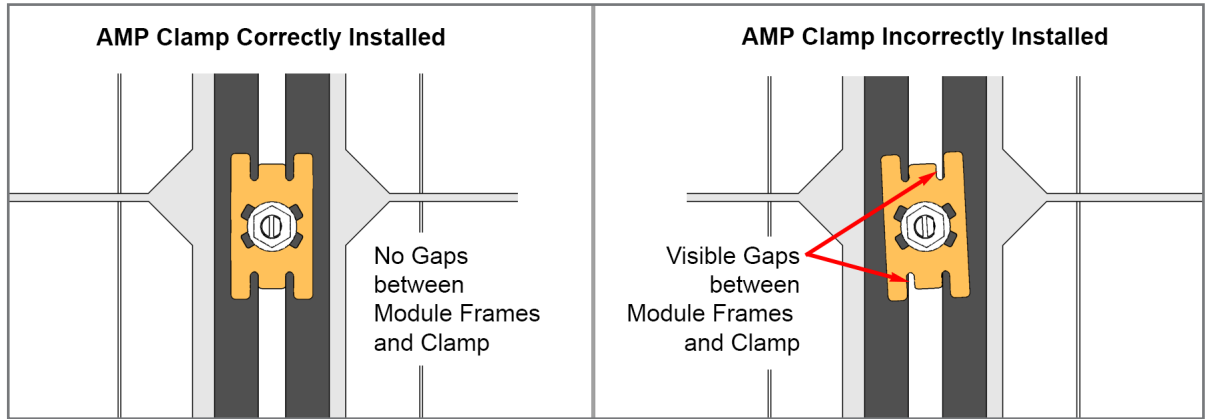

AMP Clamp bonding Mid Clamps must be installed as shown at above left and not as shown to the right. There cannot be any visible gaps between the bonding Mid Clamps and Module Frames.

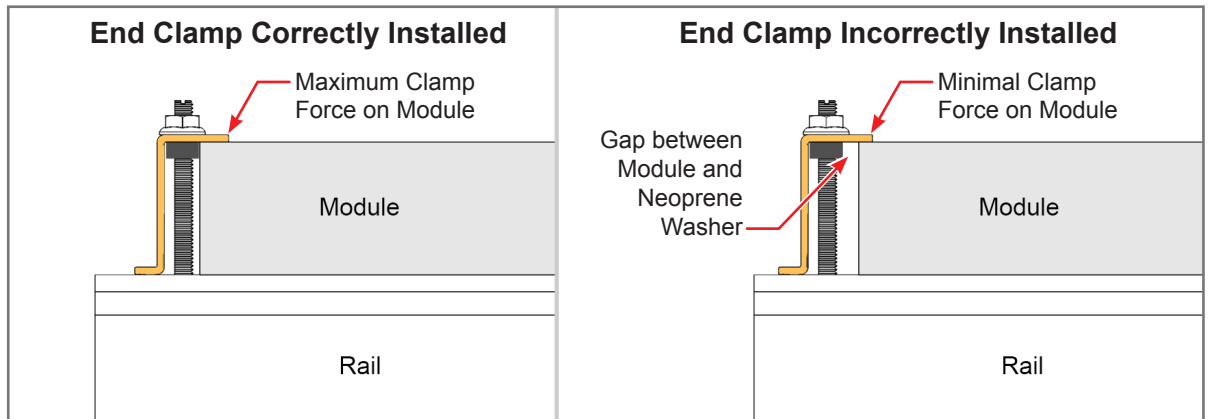

Install End Clamps by pushing the End Clamp assembly tightly against the module frame. There should not be a visible gap between the Neoprene Washer and the Module Frame.

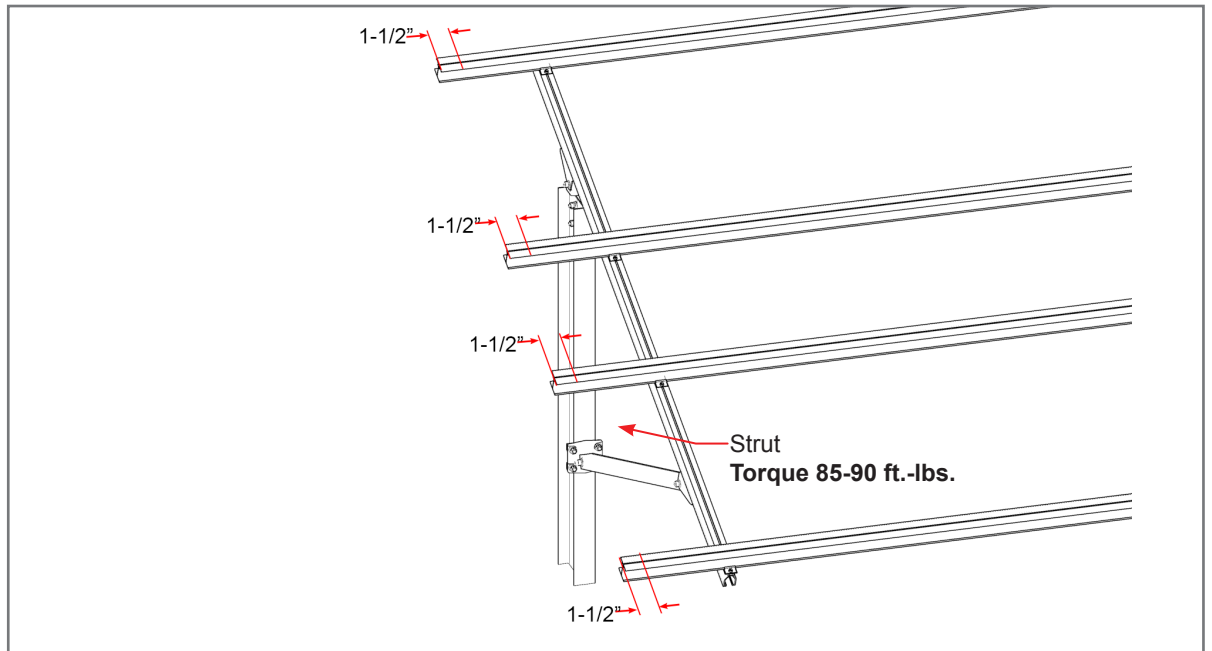

Prepare to install the Modules by first marking the Rails 1-1/2" from their ends as indicated above. The End Clamps will align to these marks.

## 11 Install the Modules (continued)

### NOTE

The RAD bolts used in the AMP Clamps and End Clamps must be locked into the channel by rotating clockwise 90-degrees. Use the indicator slot on the threaded end to identify whether or not the bolt has been locked.

### CAUTION

If the Flange Nut has been removed from the assembly, add Pentrox-A on threads of RAD Bolt before re-installing Flange Nut.

### CAUTION

Exceeding torque values can result in damage to Rail and/or Hardware.

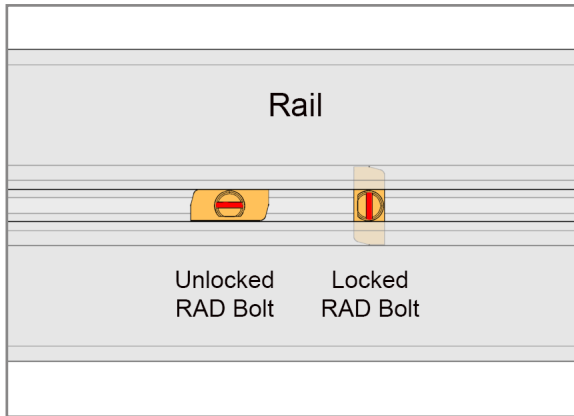

AMP Clamp bonding Mid Clamps are inserted into the Rail and positioned between adjacent Modules. Insert the 5/16" RAD Bolt into Rail and rotate 90-degrees

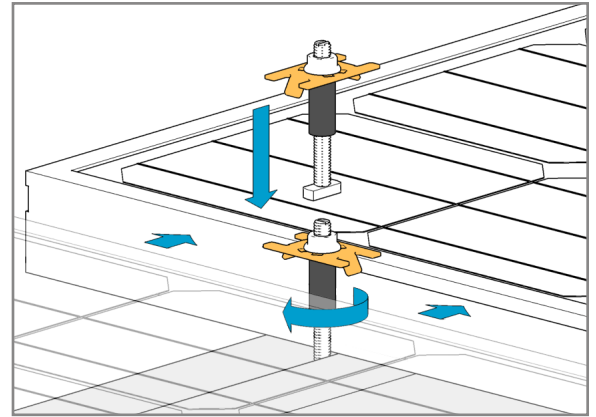

clockwise to lock the RAD Bolt within the Rail. Push Modules against AMP Clamp. Tighten 5/16" Flange Nut. **Torque to 15 ft.-lbs.**

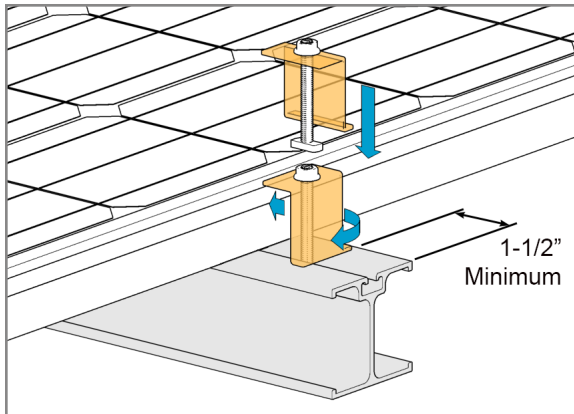

RAD End Clamps are used on the outer Modules. Insert the 5/16" RAD Bolt into Rail and rotate 90-degrees clockwise to lock the RAD Bolt within the Rail. Secure with 5/16" Flange Nut. **Torque to 15 ft.-lbs.**

## Grounding/Bonding Path

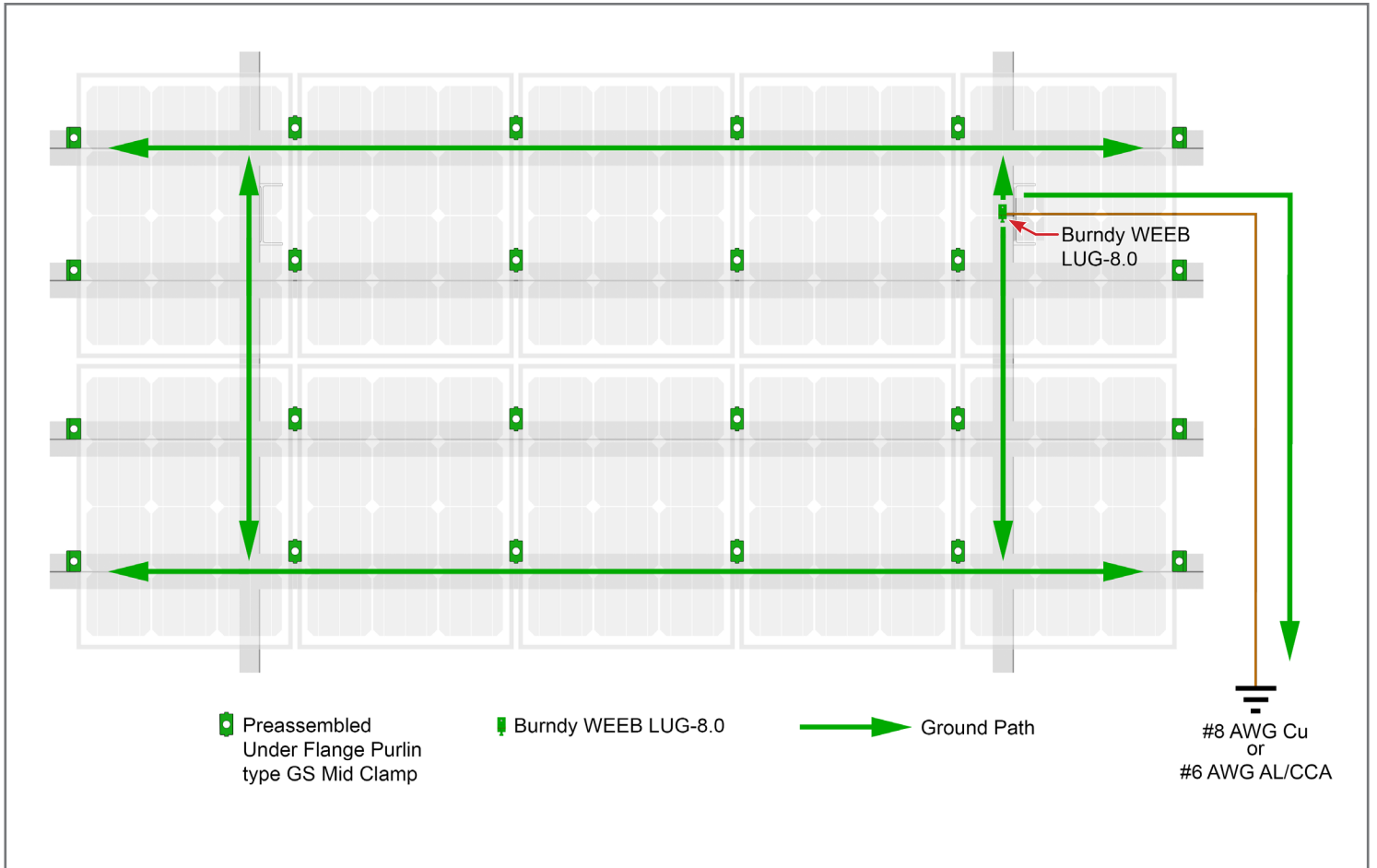



## Installing a WEEB-LUG 8.0

### IMPORTANT

Before installing verify with the lug manufacturer for any updates or revisions to these lug installation instructions.

One of two mounting methods may be used defined here as Methods A and B.

Lug is suitable for use with 14-6AWG solid or stranded copper conductor when tightened to 5ft-lbs.

### NOTE

The Turn bolts used must be locked into the channel by rotating clockwise 90-degrees. Use the indicator slot on the threaded end to identify whether or not the bolt has been locked.

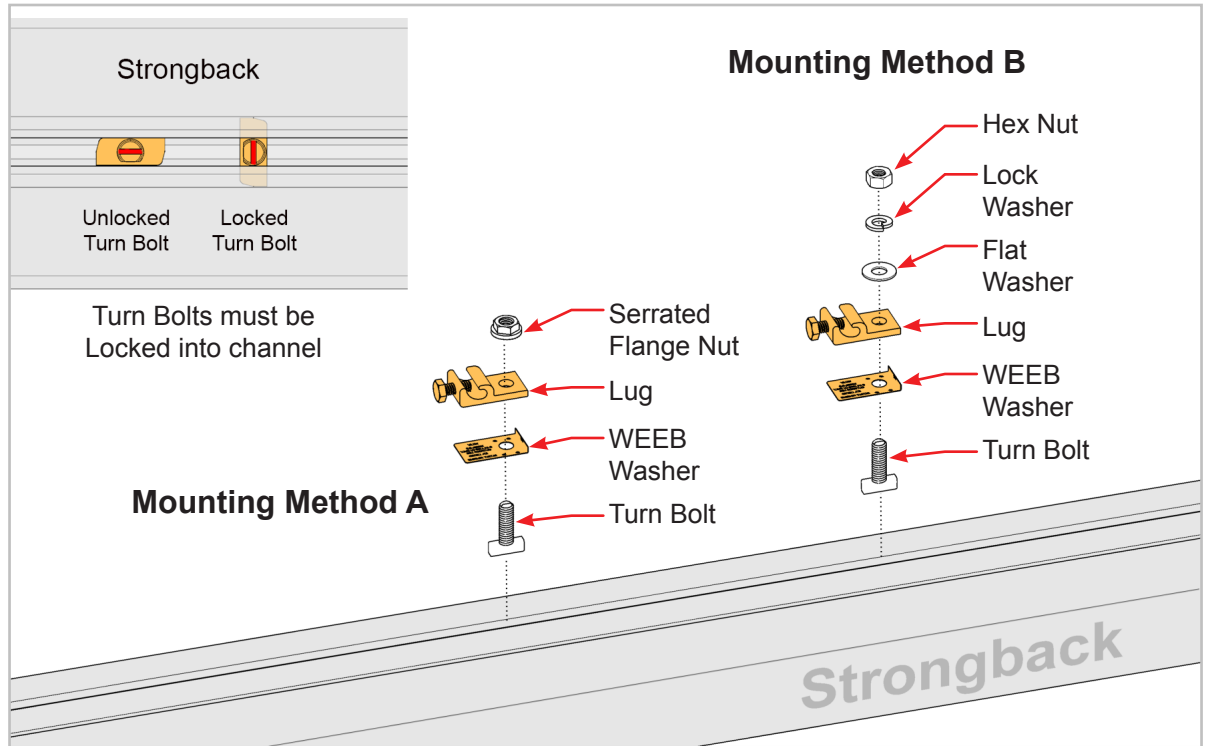

Cat No.	Max OCPD (A)	Mounting Surface					Mounting Screw		Mounting Hole Range	
		Min Profile (w x l)	Min Thick (in)	Max Thick (in)	Mtl	Surface Prep	Size	Tightening torque (lbs.-in)	Min (mm)	Max (mm)
WEEB-LUG-8.0	200	22mm x 20mm	.06"	.25"	AL	Anodized	5/16" M8	120	7.85mm	10mm
			.06"	.25"	Steel	Galvanized				

Table 1: Mounting Surface Requirements

### IMPORTANT NOTES

1. Before installing verify with the lug manufacturer for any updates or revisions to these lug installation instructions. The instructions on this page only address the WEEB-LUG-8.0 as found within the manufacturers (Burndy) document number 50016572 Rev E.
2. The NEC section 690.43 states, "Exposed non-current carrying metal parts of module frames, equipment, and conductor enclosures shall be grounded in accordance with 250.134 or 250.136 (A) regardless of voltage."
3. For Proper Equipment Grounding Conductor (EGC) and Overcurrent Protection Device (OCPD) sizing, refer to NEC sections 250.66, 250.122 and 250.166.

## Compatible Modules - these modules meet the UL2703 standard

This racking system may be used to ground and/or mount a PV module complying with UL 1703 only when the specific module has been evaluated for grounding and/or mounting in compliance with the included instructions.

Manufacturer	Frame Thickness	Model
<b>Canadian Solar</b>	40 mm	CS6P-250P, CS6P-255P, CS6P-260P, CS6P-260P-SD, CS6P-265P, CS6P-265P-SD, CS6P-270P
<b>Heliene</b>	40 mm	60P-MIM
<b>Kyocera</b>	46 mm	KU250-6BCA, KU255-6BCA, KU260-6BCA, KU265-6BCA
<b>LG</b>	35 mm	LG300N1C-G3, LG305N1C-G3, LG310N1C-G3
	36 mm	LG365N2W-B3, LG375N2W-B3
	40 mm	LG320N1C-G4, LG325N1C-G4, LG 335N1C-G4, LG340N1C-G4
	46 mm	LG375N2W-G4
<b>REC Solar</b>	35 mm	REC265TP, REC270TP, REC275TP, REC280TP, REC285
	38 mm	REC240PE, REC245PE, REC250PE, REC255PE, REC260PE, REC265PE, REC270PE
<b>Silfab</b>	38 mm	SLA260M, SLA265M, SLA270M, SLA275M, SLA280M, SLA285M, SLA290M, SLA295M, SLA300M
<b>Solar World</b>	31 mm	SW280 31mm
	33 mm	SW280, 285, 290, 295, 300 33 mm, SW 320 XL 33mm FR, SW 325 XL 33mm FR, SW 330 XL 33mm FR, SW 335 XL 33mm FR, SW 340 XL 33mm FR, SW 345 XL 33mm FR, SW 350 XL 33mm FR
<b>Suniva</b>	38 mm	OPT-275-60-4-100, OPT-280-60-4-100, OPT-285-60-4-100, OPT-290-60-4-100, OPT-295-60-4-100, OPT-300-60-4-100
<b>Sunpower</b>	46 mm	SPR-327NE-WHT-D, SPR-333NE-WHT-D, X21-335-BLK, X21-345-BLK
<b>Suntech</b>	50 mm	STP270-24/Vd, STP275-24/Vd, STP280-24/Vd, STP285-24/Vd, STP290-24/Vd, STP295-24/Vd, STP300-24/Vd, STP305-24/Vd
<b>Topoint Solar</b>	35 mm	JTM185-72M, JTM190-72M, JTM195-72M, JTM200-72M
<b>Trina</b>	40 mm	TSM-290PD14, TSM-295PD14, TSM-300PD14, TSM-305PD14, TSM-310PD14, TSM-315PD14, TSM-320PD14, TSM-325PD14



## **PREFORMED** LINE PRODUCTS

---

Albuquerque Office  
1700 Louisiana Blvd., Suite 130  
Albuquerque, NM 87110

Corporate Headquarters  
660 Beta Drive  
Mayfield Village, OH 44143

Telephone: 800.260.3792  
Fax: 505.889.3548  
[www.preformed.com](http://www.preformed.com)  
E-mail: [info@plpsolar.com](mailto:info@plpsolar.com)