

Ballasted POWER PEAK™

ASSEMBLY INSTRUCTIONS

step-by-step
assembly and installation

Ballasted Power Peak™ Ratings

The Ballasted Power Peak™ conforms to ANSI/UL UL2703 (2015) Standard for Safety First Edition: Mounting Systems, Mounting Devices, Clamping/Retention Devices, and Ground Lugs for Use with Flat-Plate Photovoltaic Modules and Panels.

Electrical

Note: Electrical installations must be in accordance with the National Electric Code ANSI / NFPA 70. Contact your local Authorities Having Jurisdiction (AHJ) for additional details.

Max Overcurrent Protective Device (OCPD) Rating: 25A

Equipment Grounding Conductor Sizing:

Module Fuse Rating	Copper Wire Size
<15 AMPS	#14 AWG 90°C
<20 AMPS	#12 AWG 90°C
20-60 AMPS	#10 AWG 90°C

Structural Certification

Mechanical Load Rating: Designed and Certified for Compliance with IBC & ASCE/SEI-7 through separate PE reviews.

Marking

Product markings identified per UL2703 are to be located in a location that is readily accessible for inspection.

Periodic Inspection

Periodic re-inspection is a recommended system maintenance procedure to check for loose components or corrosion. If any loose components and/or corrosion is found, the affected components are required to be replaced immediately, with the original mounting system manufacturer's component parts.

Ballasted Power Peak™

WARNING

Follow the procedures and precautions in these instructions carefully.

About the product

The Ballasted Power Peak™ system is designed for project sites with unfavorable soils or ground conditions that prohibit pile driving. Each Ballasted Power Peak system is engineered to site-specific environments and arrives on the project site ready to assemble on precast or poured-in-place concrete bases. PV modules are mounted in a two-row portrait configuration where the number of modules in each row match the string size for easier and more efficient wire management.

The Ballasted Power Peak system features bottom access PV module clamping which eliminates the need for ladders. The module clamps are preassembled with no loose parts for faster installation rates and provide code-compliant integrated electrical bonding.

The Ballasted Power Peak system features “C” channel verticals with adjustable bases that allow for uneven ballast blocks and terrain changes. Multiple vertical and horizontal slots and adjustments allow the table tops to be quickly squared resulting in faster PV module placement and a professional finish.

Important Installation Considerations

Block size requirements are based on several factors including the array surface area, maximum design wind speed, exposure category, snow loading, tilt angle, soil type and front edge clearance.

Consulting with a local building department and/or professional engineer is recommended.

For block size recommendations on a specific installation, please:

Contact us by Phone: 800-260-3792

Send an Email request: info@plpsolar.com

Grounding Considerations

The Ballasted Power Peak utilizes integrated module grounding clamps designed to meet UL 2703 grounding standards.

About these instructions:

- They include information on assembling the product and are intended to be used by individuals with sufficient technical skills for the task. Knowledge and use of hand tools, measuring devices and torque values is also required.
- They include various Notes, Cautions, and Warnings that are intended to draw your attention and assist in the assembly process and/or to draw attention to the fact that certain assembly steps may be dangerous and could cause serious physical injury and/or damage to components. Follow the procedures and precautions in these instructions carefully.

Required Tools

- 7/8 inch wrench or socket for 1/2 inch module clamp hardware
- 1/2 inch wrench or socket for 5/16 inch hardware
- Torque wrench
- Ratchet wrench
- Ratchet extension bar
- String
- Framing Square
- Tape Measure
- Inclinator

Ballasted Power Peak Main Components

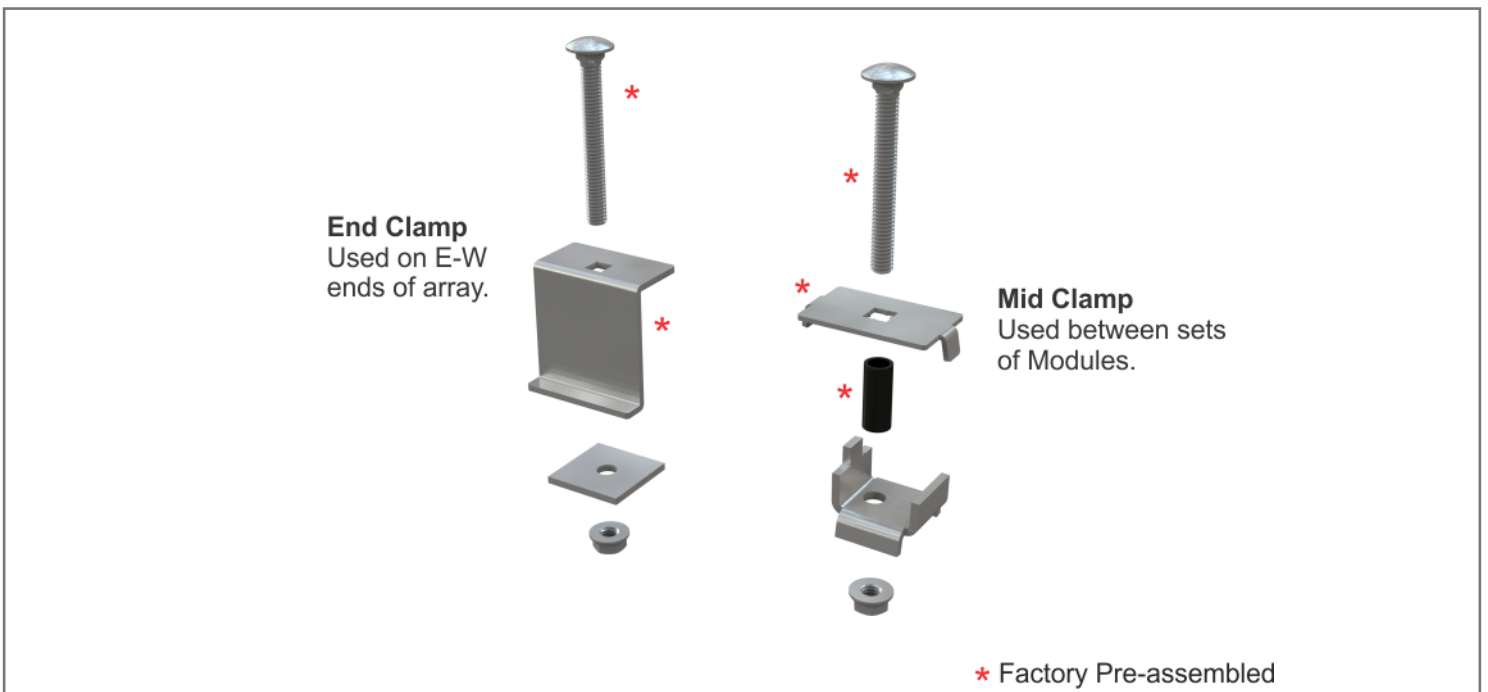
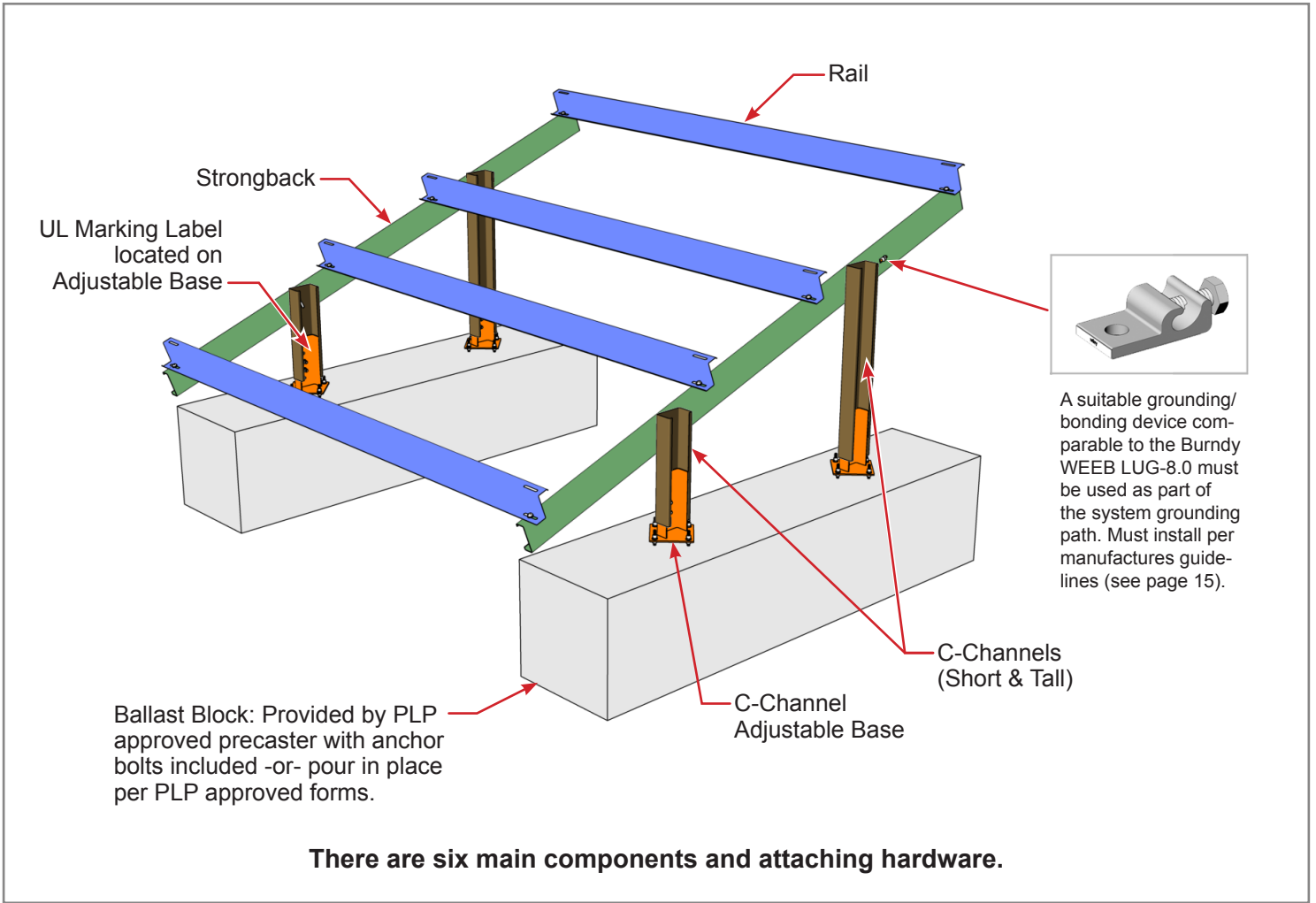

1 Set Concrete Ballast Blocks

CAUTION
 Failure to meet the site specific ballast requirements can lead to structural failure and/or serious injury or death. Additionally, it would void the system warranty.

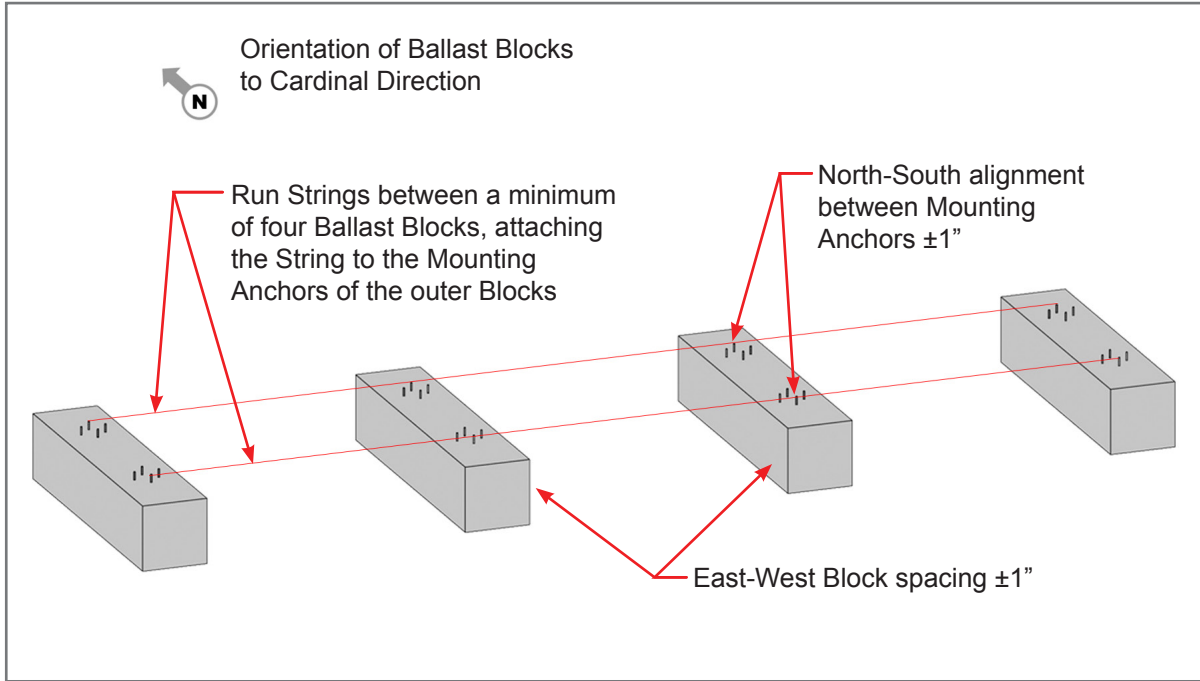

Set Ballast Blocks to match the site specific drawings.

2 Install the Adjustable Bases

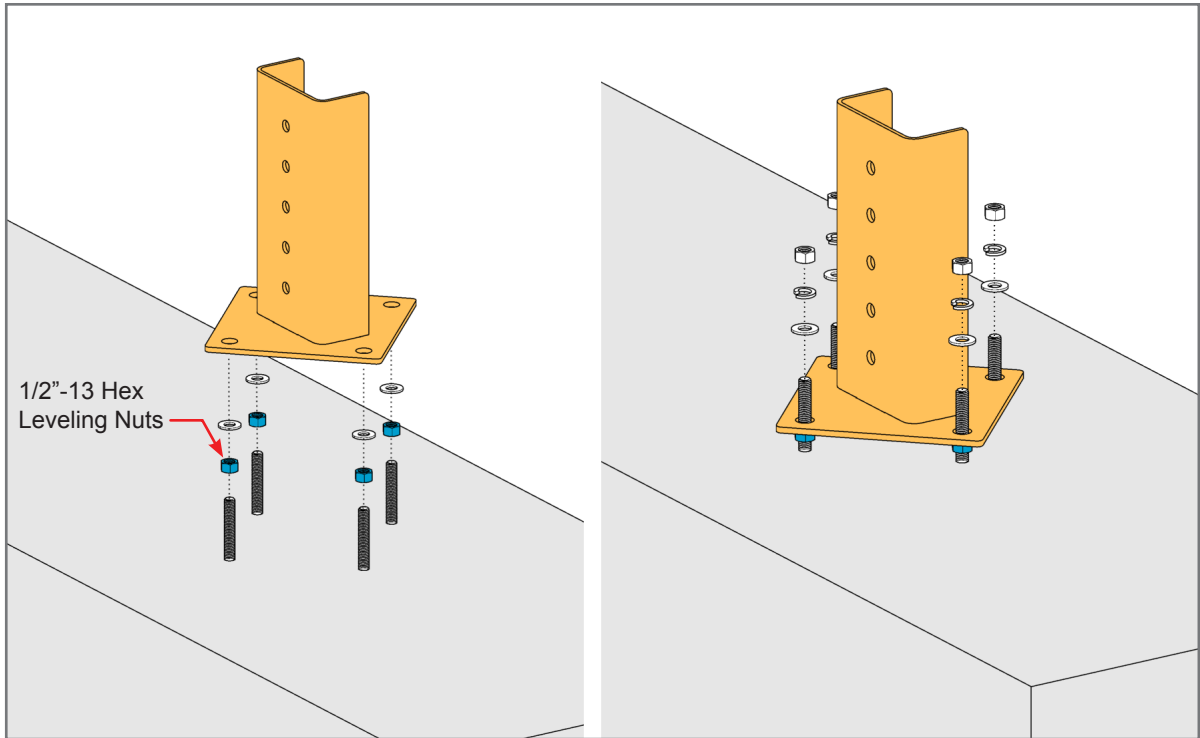

Install the Adjustable Bases by first threading four 1/2"-13 Hex Leveling Nuts and Flat Washers followed by the Adjustable Base. Install the remaining 1/2" hardware (Nuts, Lock and Flat Washers) but do not tighten at this time as they must be loose in order to level and plumb each Adjustable Base.

3 Plumb/Level the Adjustable Base

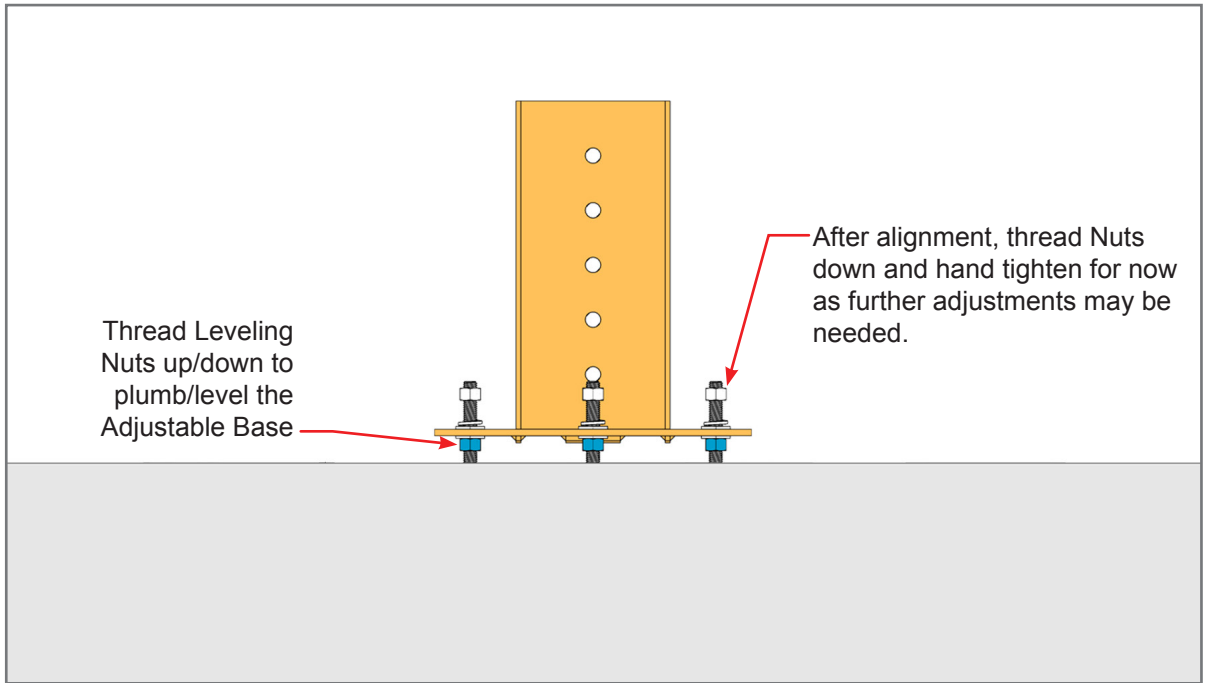

Use a level to plumb each Adjustable Base.

4 Install the Legs

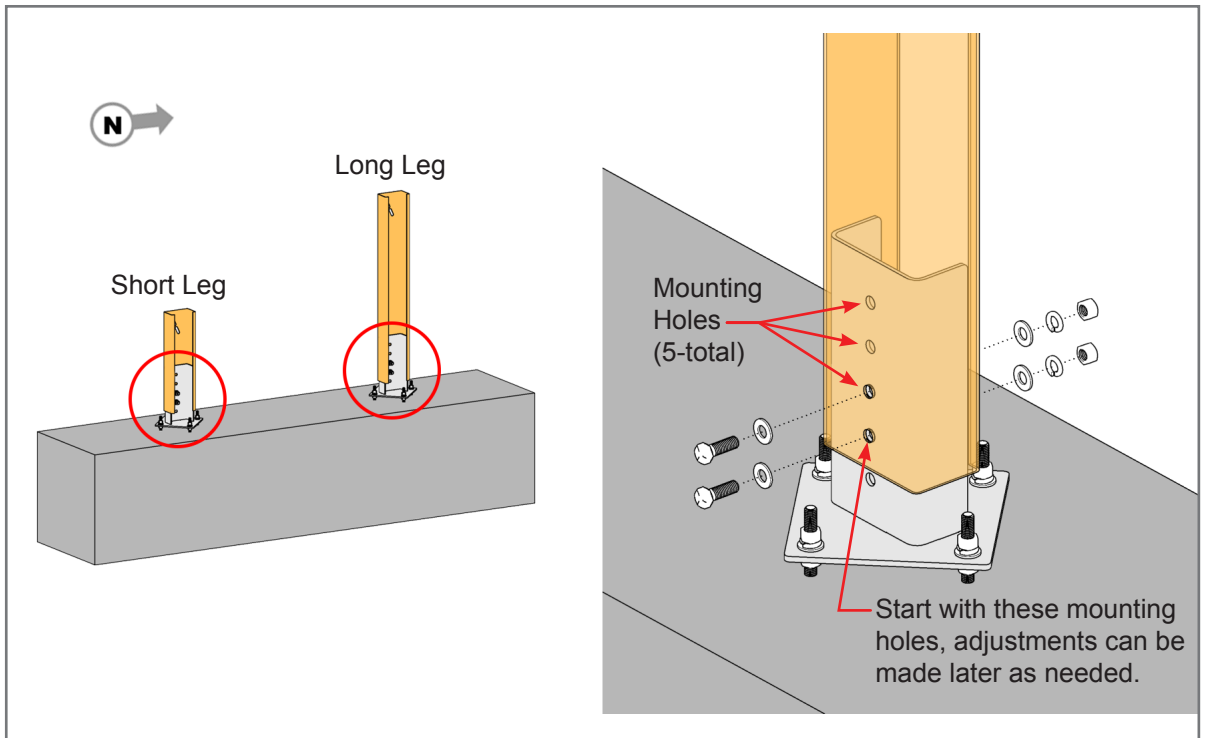

The five mounting holes of the Adjustable Base represent four possible vertical mounting positions when attaching the Legs. Install the Legs with sets of two 1/2"-13 x 1-1/2" Hex Bolt, Flat Washers, Lock Washer and Hex Nut. Hand tighten for now, tool tighten after legs have been leveled (see next step).

5 Level C-Channel Attachments from N-S

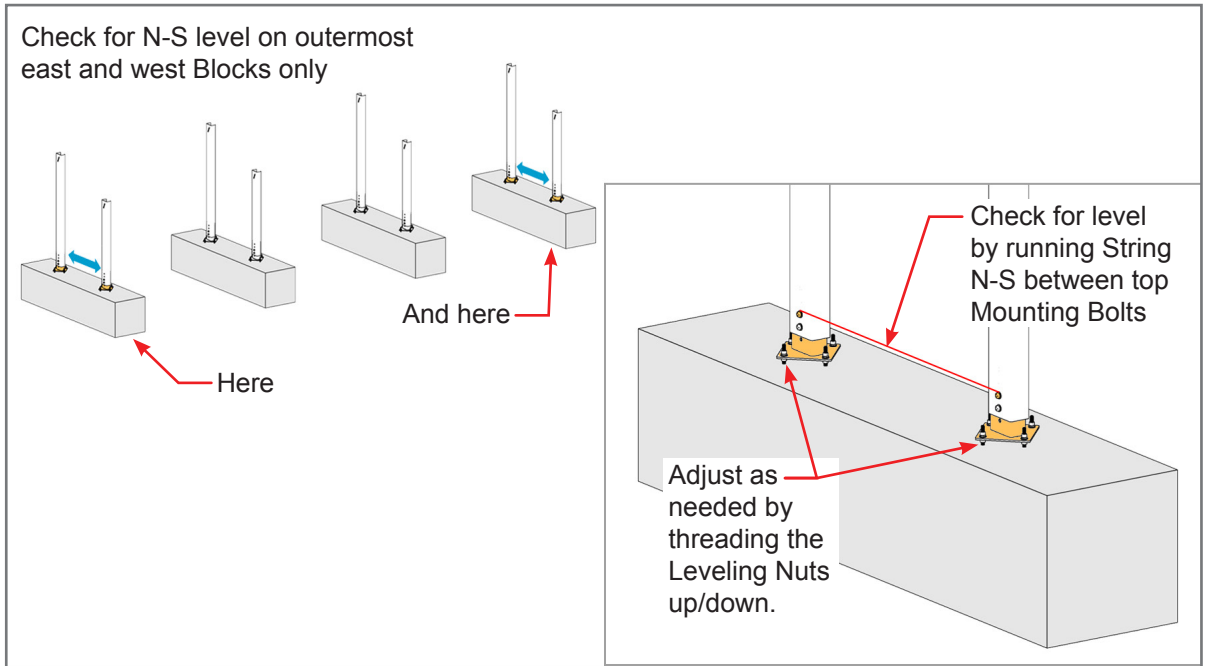

Adjust the N-S Leg elevations on the outer most east and west blocks as shown. The interior blocks will be brought into alignment in step 6. After adjustments are complete, tighten hardware on these outer blocks and Torque Adjustable Base hardware to **50-55 ft.-lbs.** Torque Leg hardware **65-70 ft.-lbs.**

6 Level and Secure the Legs

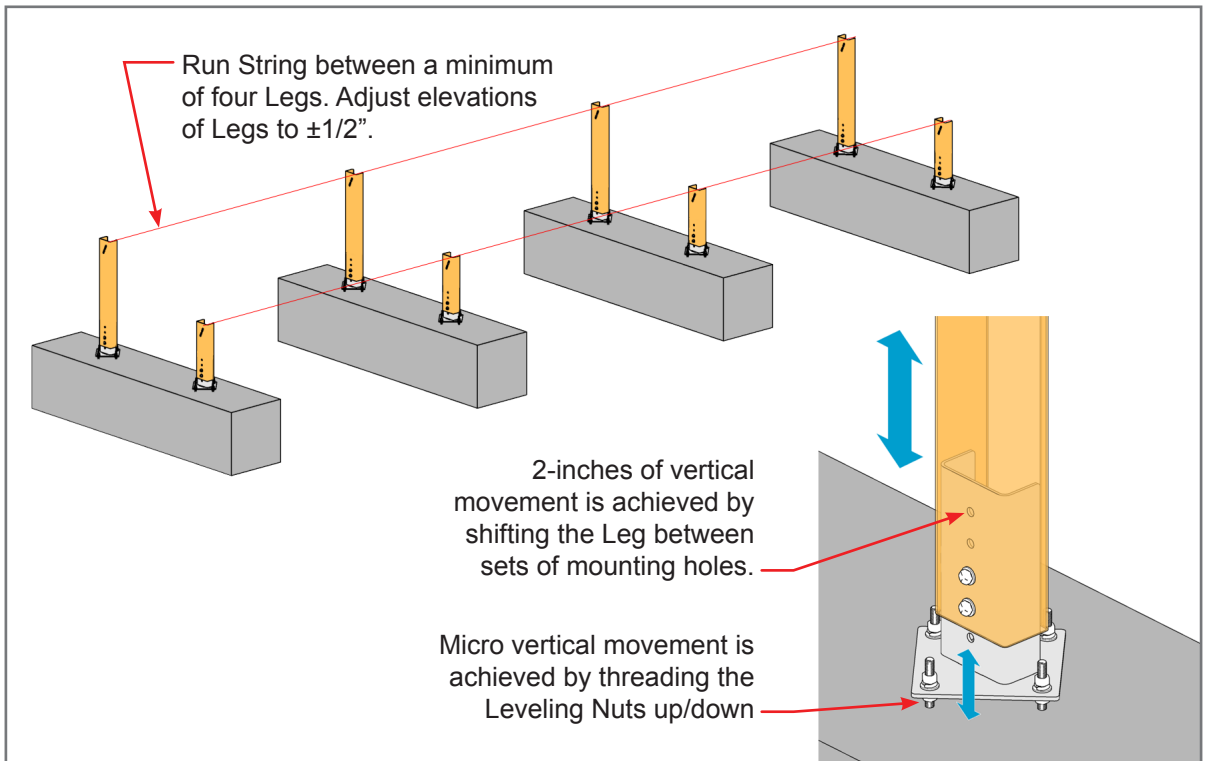

Adjust Leg elevations by shifting Leg(s) to the next set of mounting holes on the Adjustable Base, and/or by using the Leveling Nuts under the Adjustable Base for finer micro adjustments. Verify that legs are still plumb, then Torque Adjustable Base hardware to **50-55 ft.-lbs.** Torque Leg hardware **65-70 ft.-lbs.**

7 Install and Align the Strongback

NOTE
 At this stage the Strongback positioning is considered a temporary position - the intent is to establish a starting position for each Strongback. Further adjustments to align the Strongbacks will take place later.

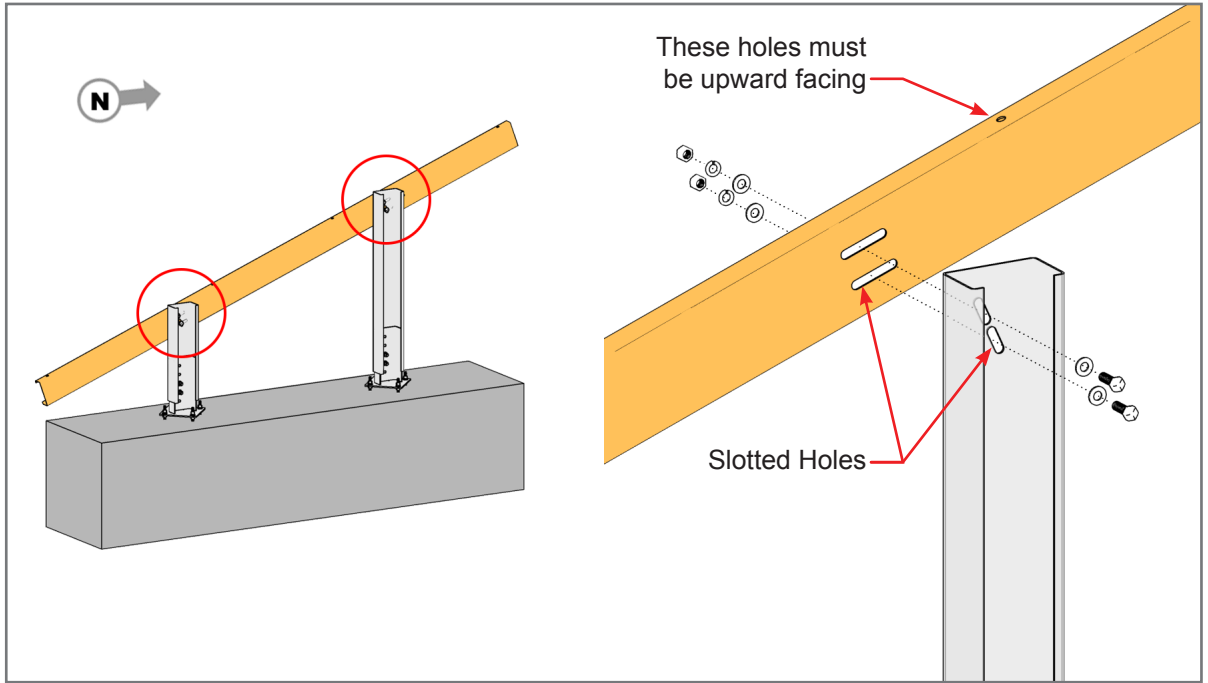

Install the Strongback using 1/2"-13 x 1-1/2" Hex Bolt, Flat Washers, Lock Washer and Hex Nut. For now, adjust the Strongback position so its slotted

holes are centered with the slotted holes of the Legs. **Tool tighten hardware for now to hold the Strongback in place.**

8 Align Strongbacks and Set their Tilt Angle

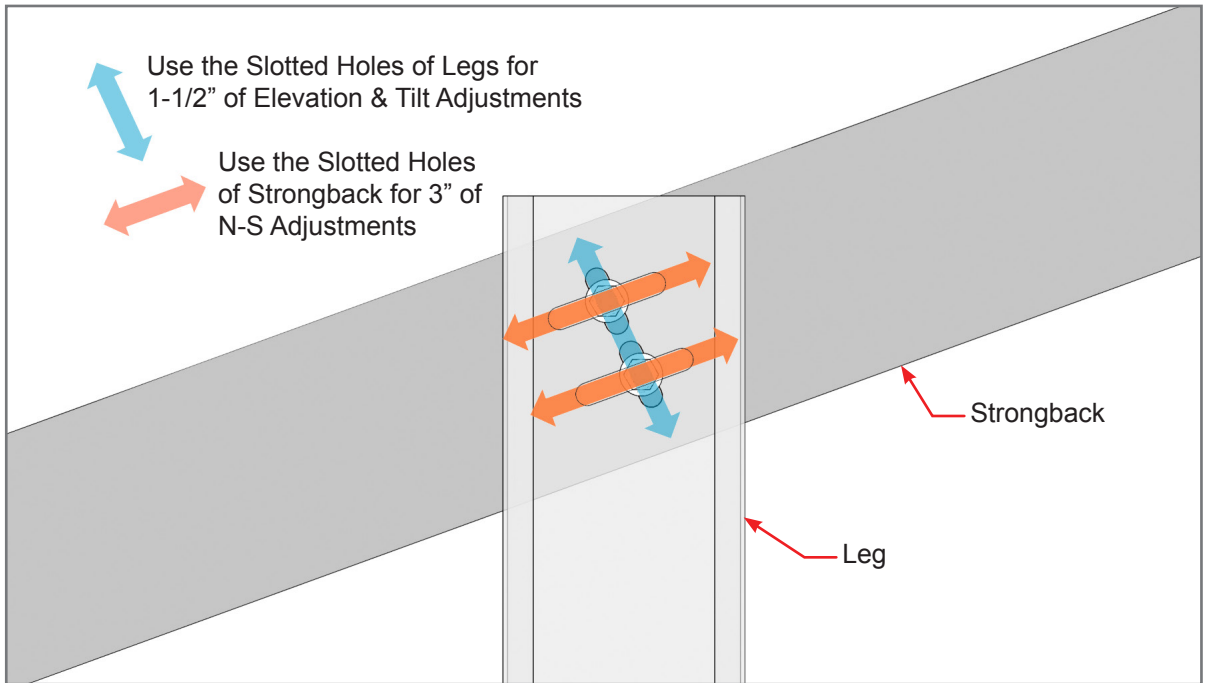

Using string and an inclinometer the Strongbacks can be aligned and tilted in one procedure. The slotted holes of the Strongback provide for its N-S movement while the slotted holes of the Legs provide for its elevation and tilt adjustments.

1. Pull string lines at north and south ends of outer Strongbacks.
2. Place inclinometers on outer Strongbacks.
3. Align and set the tilt angle on the outer Strongbacks.
4. Align and set the tilt angle on inner Strongbacks by aligning them to the Strings.
5. Tighten all hardware securing the Strongbacks to Legs. **Torque to 65-70 ft.-lbs.**

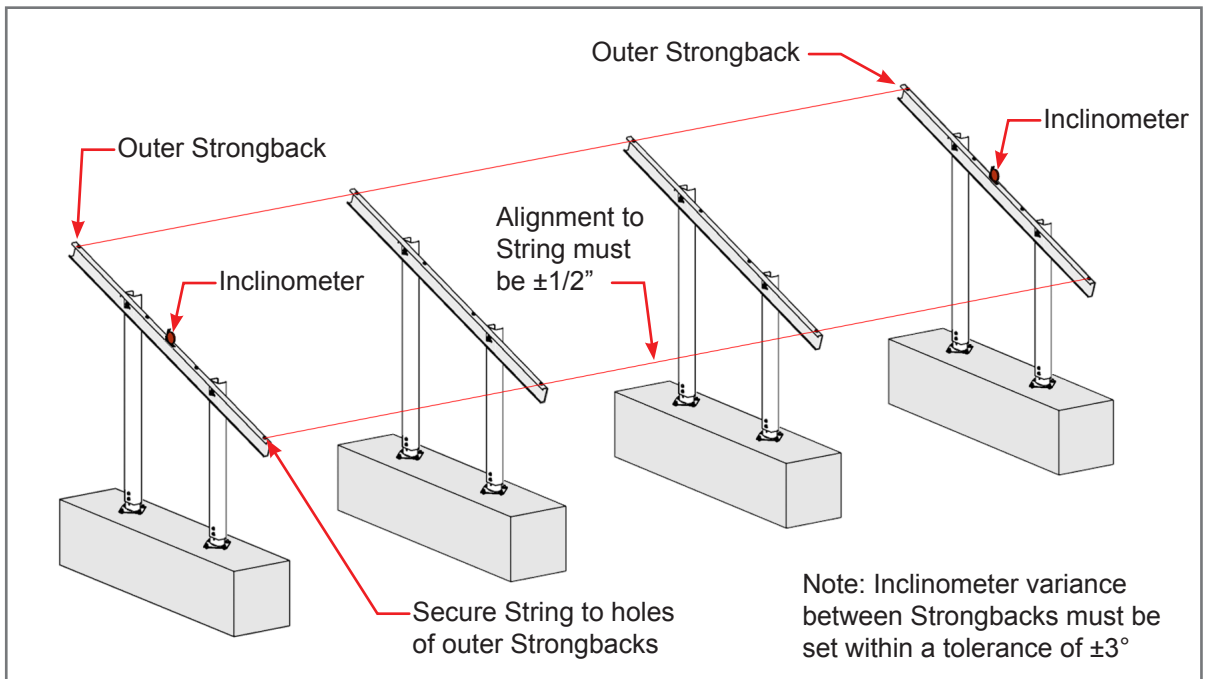

9 Attach the Rails to the Strongbacks

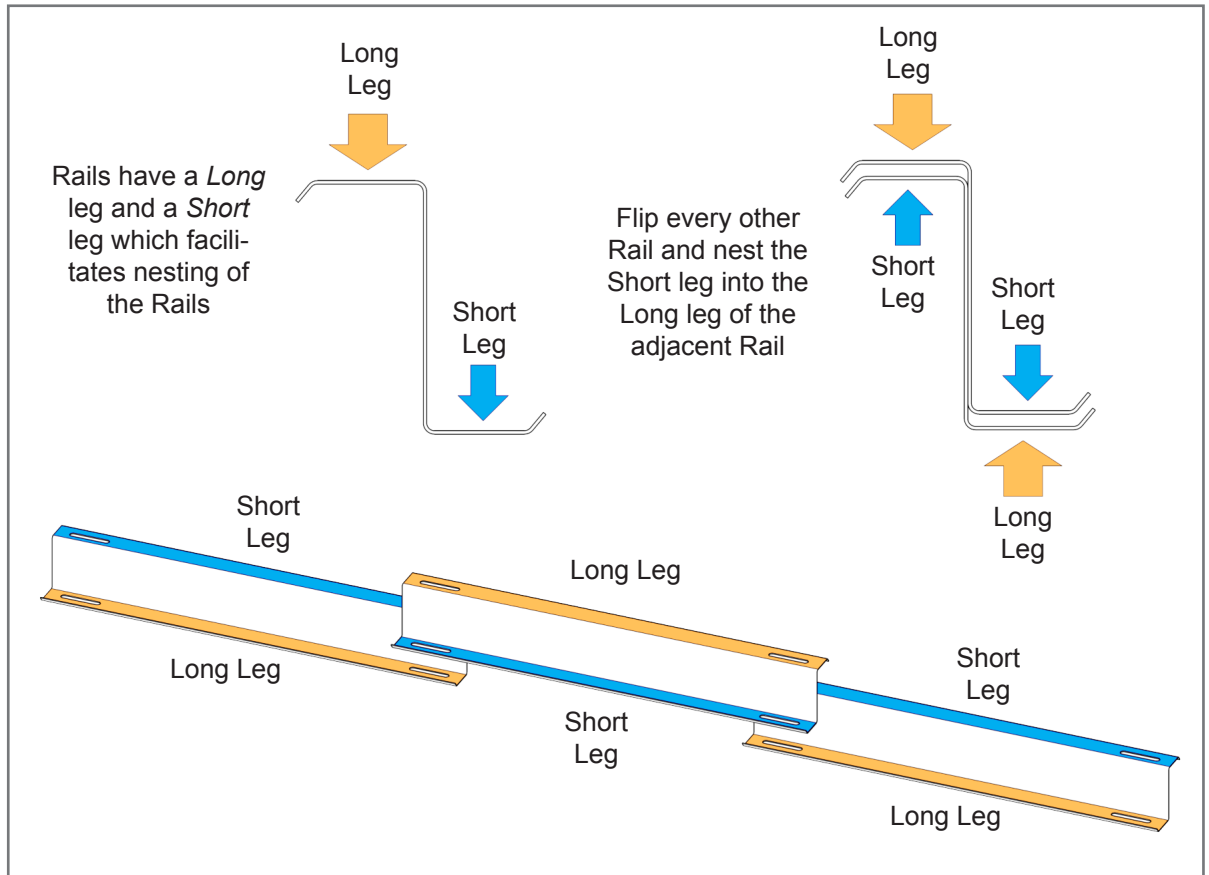

The Rails must have an alternating overlap. As shown above, the Rails are designed to overlap by aligning their slotted holes and nest into one another by alternating and mating a *Short* leg with a *Long* leg.

Where overlapping occurs, Rail lengths provide for as much as 6" of overlap. Make sure that with each overlapping Rail the slotted holes overlap and are in alignment.

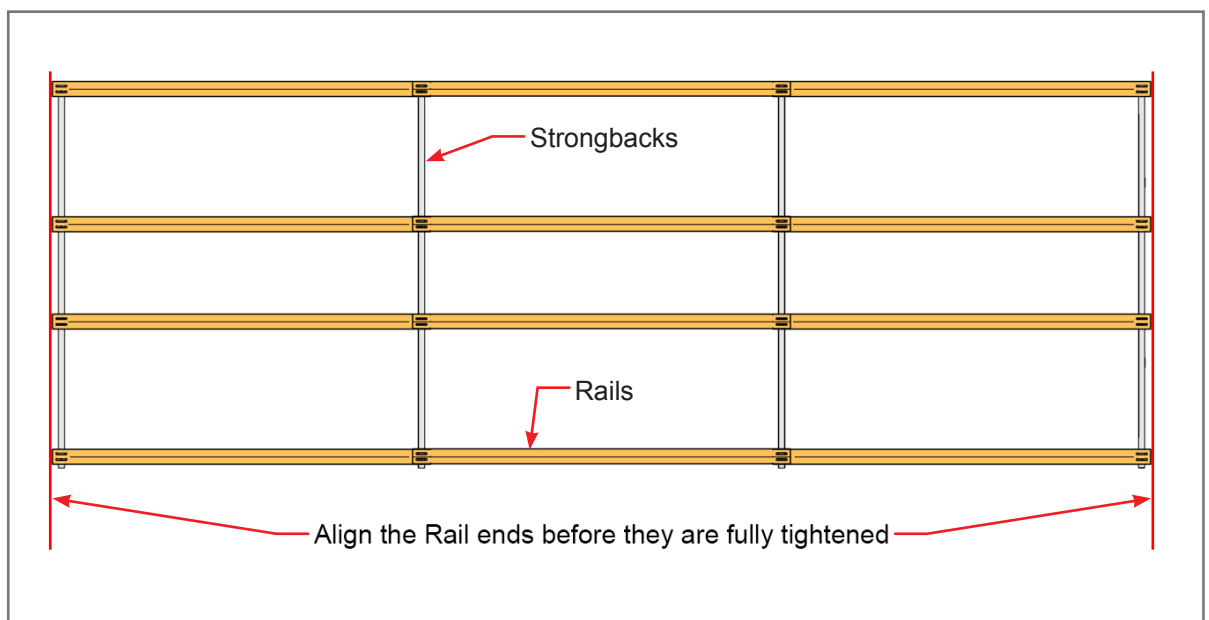

Align the Rail ends at E-W edges of the array before tightening hardware.

9 Attach the Rails to the Strongbacks (continued)

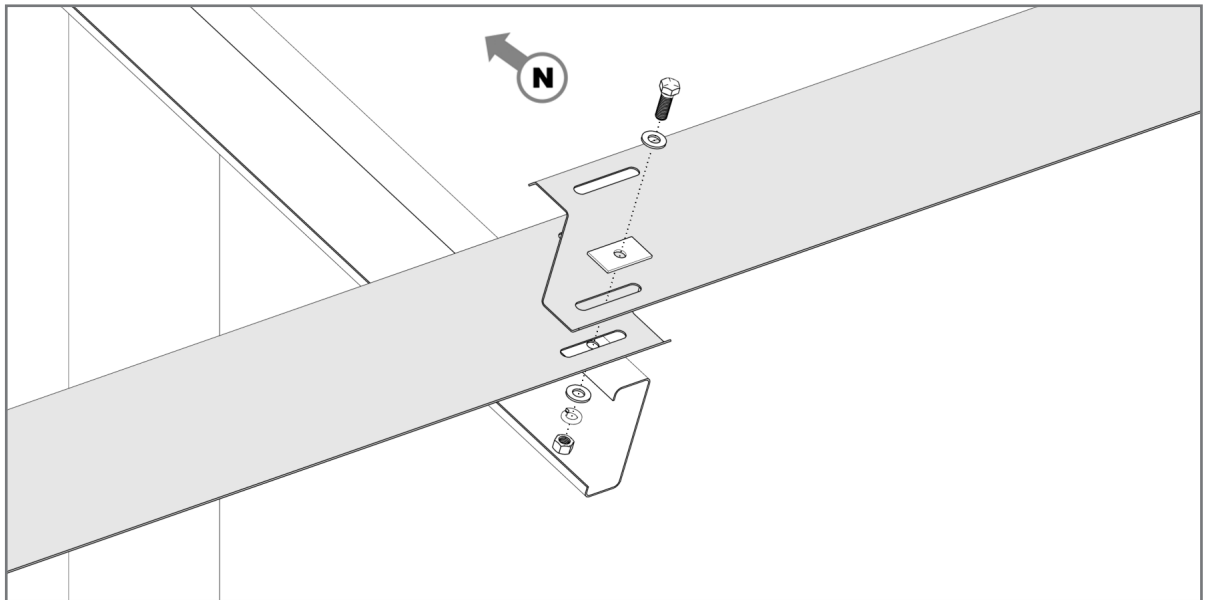

Be sure to orient the Rail as shown above. The upper flange must be pointing north. The mounting holes of the Rails are slotted for E-W directional adjustments and alignment as the Rails are installed. Secure Rails

with 1/2"-13 x 1-1/2" Hex Bolt, Flat Washers, Lock Washer and Hex Nut. After aligning their ends, tighten and **torque to 65-70 ft.-lbs.**

NOTE

The Rail Reinforcement Bracket is not used on all systems, it is an optional item. It's primarily used in those regions where heavy snow loads may occur.

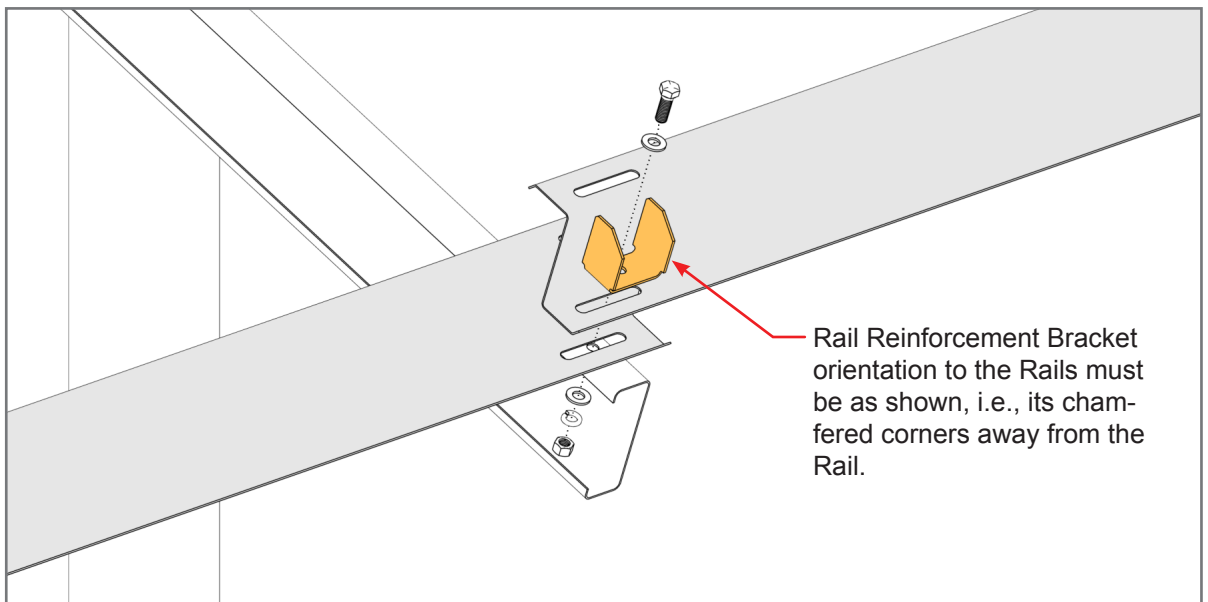

Install the Rail Reinforcement Bracket (optional item). Secure Rails and Reinforcement Bracket with 1/2"-13 x 1-1/2" Hex Bolt, Flat Washers, Lock Washer and Hex Nut. After aligning their ends, tighten and **torque to 65-70 ft.-lbs.**

10 Tighten and Torque the Hardware

CAUTION

Exceeding torque values can result in damage to components and/or Hardware.

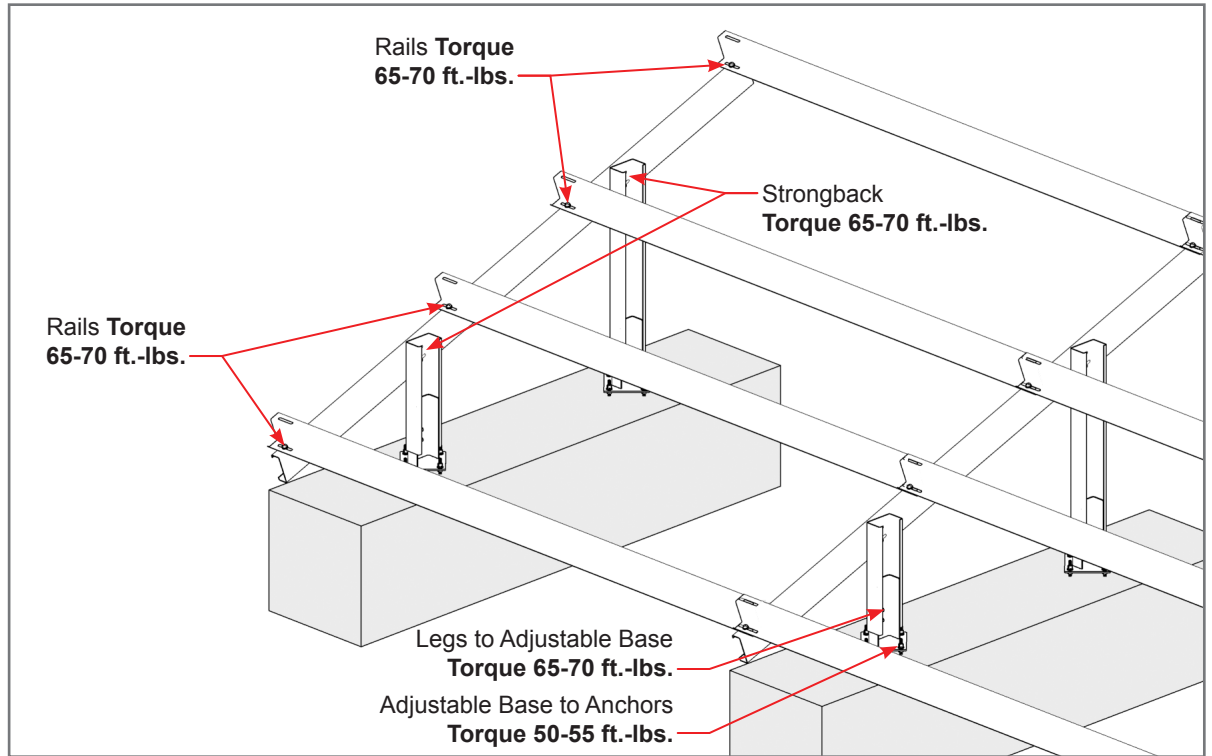

It's extremely important to tighten and torque all hardware as specified above.

11 Installing the Modules

TIP!

1. Work sequentially, installing the Modules by columns.
2. Periodically check to ensure that the Modules are square to the Rails.
3. Make a simple Module positioning jig to quickly and accurately center the Modules over the Rails.
4. Always tighten each Module's Clamps before installing the next-in-line Module.

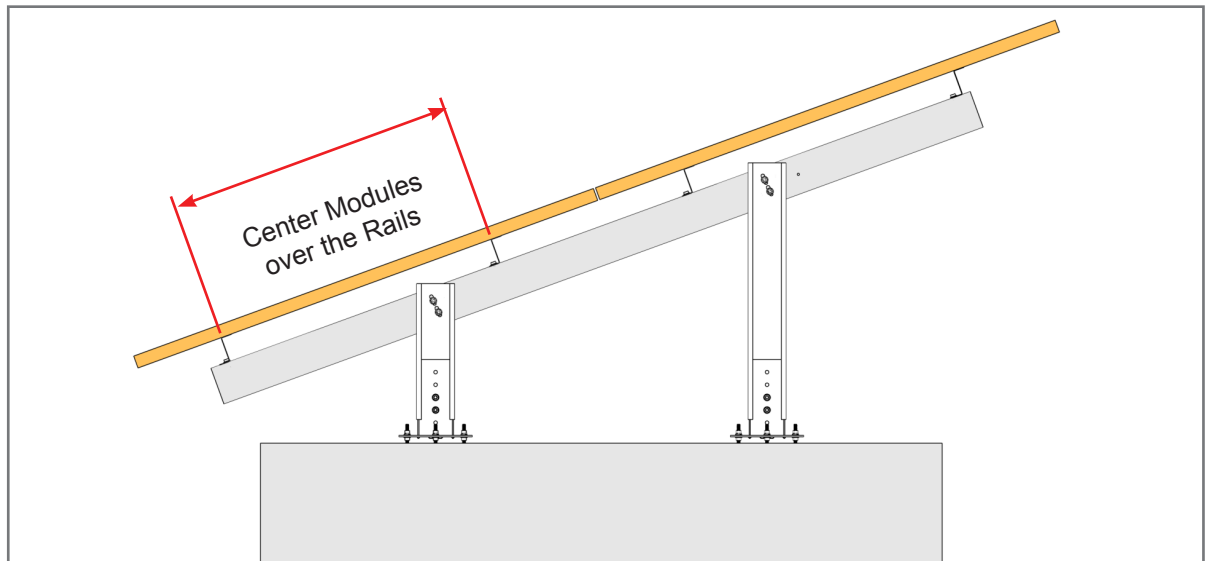
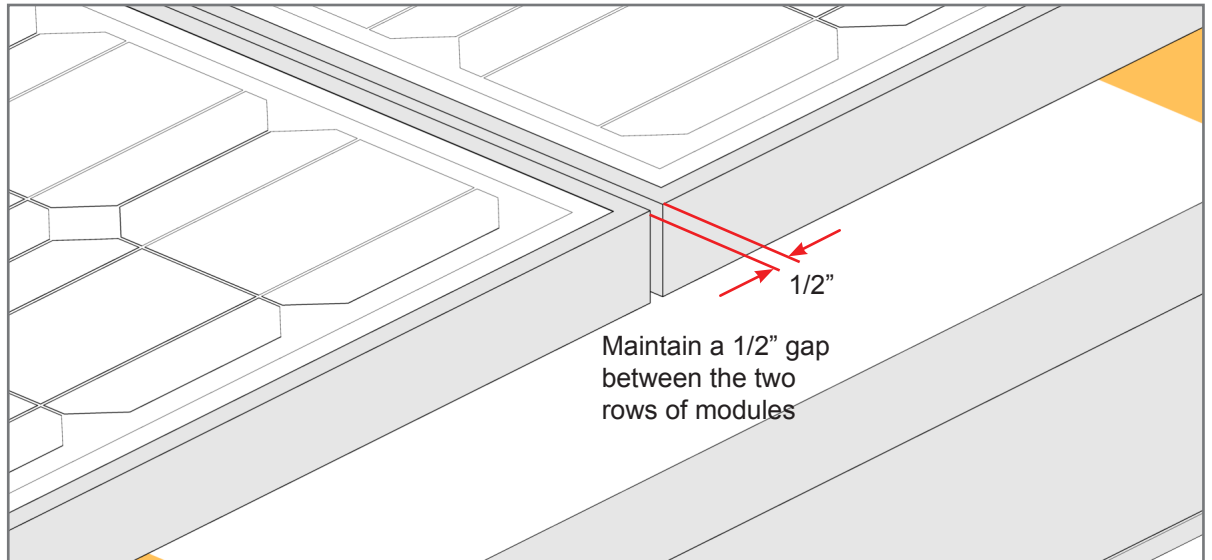
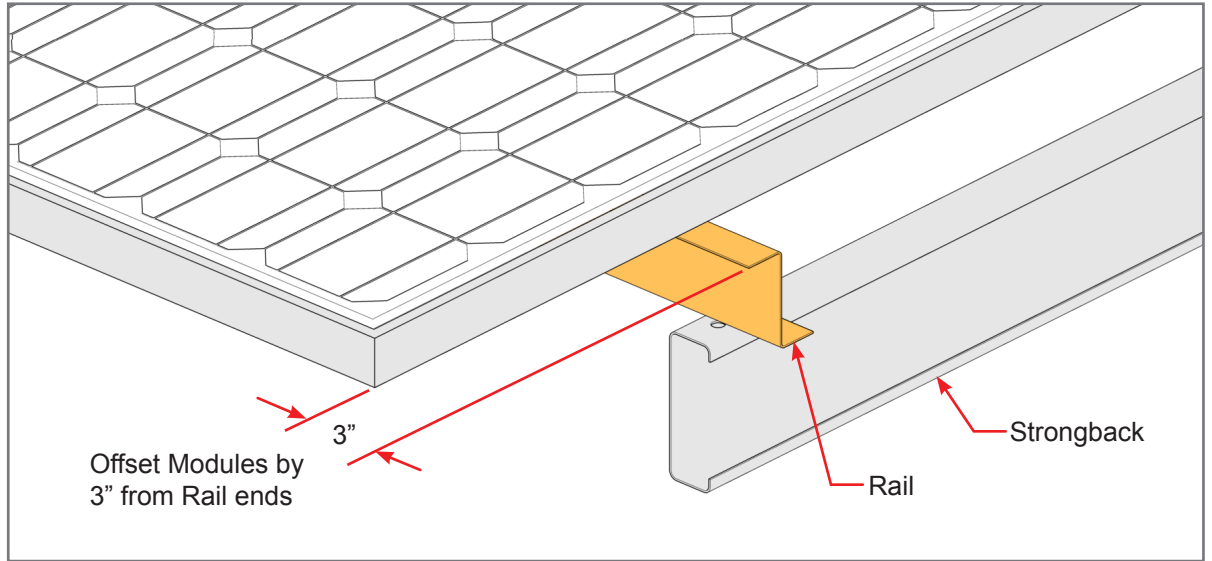

11 Installing the Modules (continued)

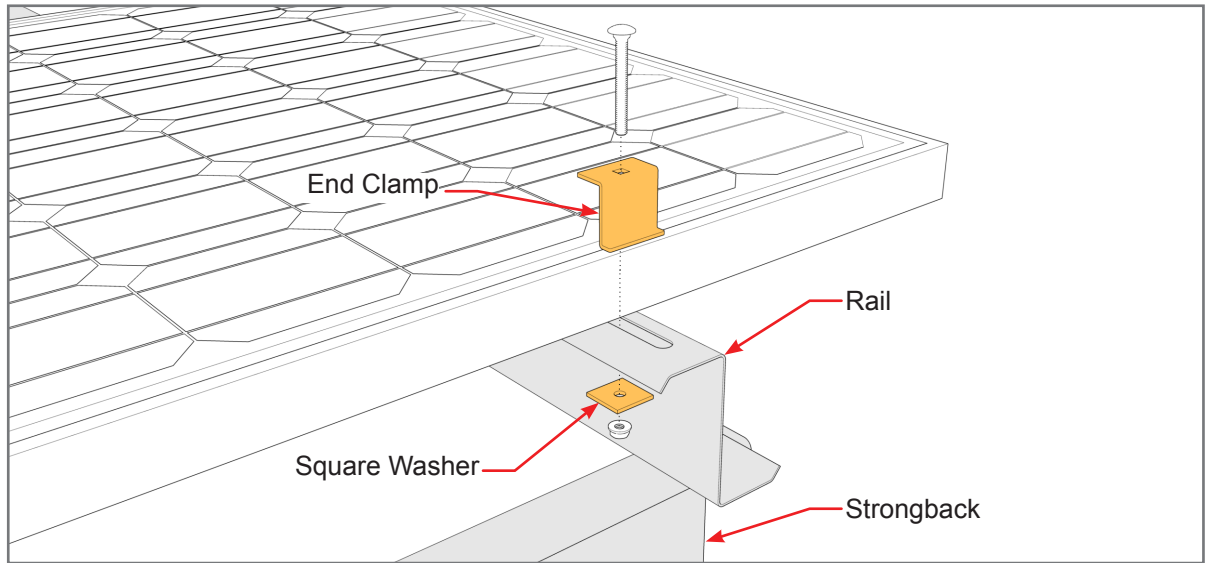

Installing End Clamps. The End Clamp is used only in the orientation shown above. Do not attempt to flip the End Clamp over or use in any other orientation. Secure Module to Rails with 5/16" Carriage Bolt, End Clamp, Square Washer and Flange Nut. **Torque to 15 ft.-lbs.**

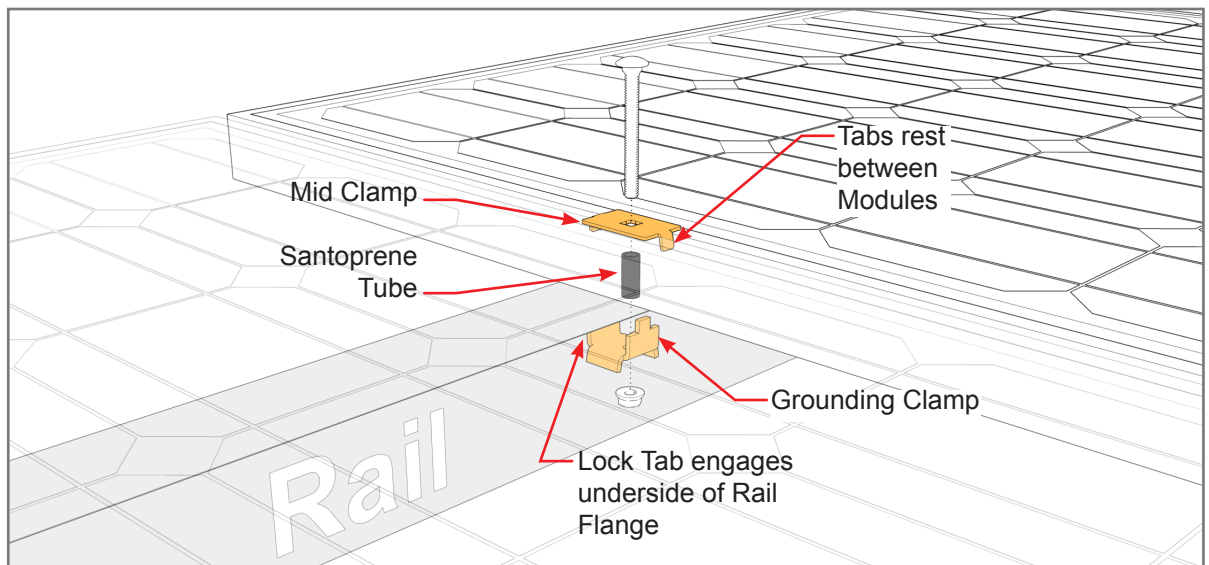

Installing Mid Clamps. Secure Module to Rails with 5/16" Carriage Bolt, Mid Clamp, Santoprene Tube, Grounding Clamp and Flange Nut. **Torque to 15 ft.-lbs.**

Mid Clamp Installation

Position the Mid Clamp Assembly with the tabs of the Mid Clamp and the Grounding Clamp between the two Modules. Additionally, position the Lock Tab underneath the Rail Flange and push the entire Mid Clamp Assembly against the Rail, ensuring the maximum holding pressure of the Lock Tab to the Rail.

Ensure that the Modules are pushed up against the tabs and the Clamps are square to the Modules.

The Grounding Clamp has small engagement points that penetrate the finish of the Module frame(s) creating an electrical bond to the Rail.

Grounding/Bonding Path

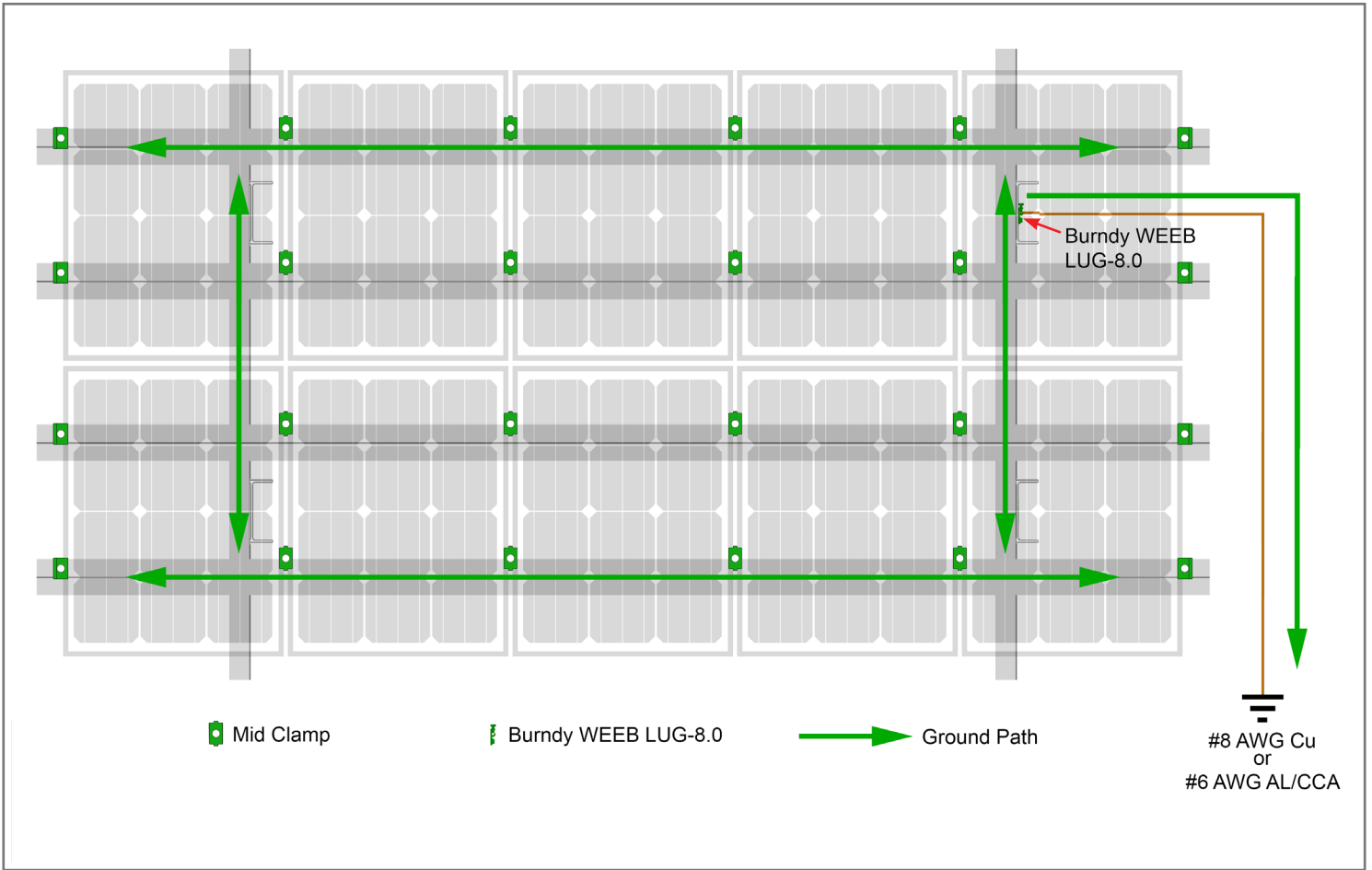

Installing a WEEB-LUG 8.0

IMPORTANT

Before installing verify with the lug manufacturer for any updates or revisions to these lug installation instructions.

One of two mounting methods may be used defined here as Methods A and B.

Lug is suitable for use with 14-6AWG solid or stranded copper conductor when tightened to 5ft-lbs.

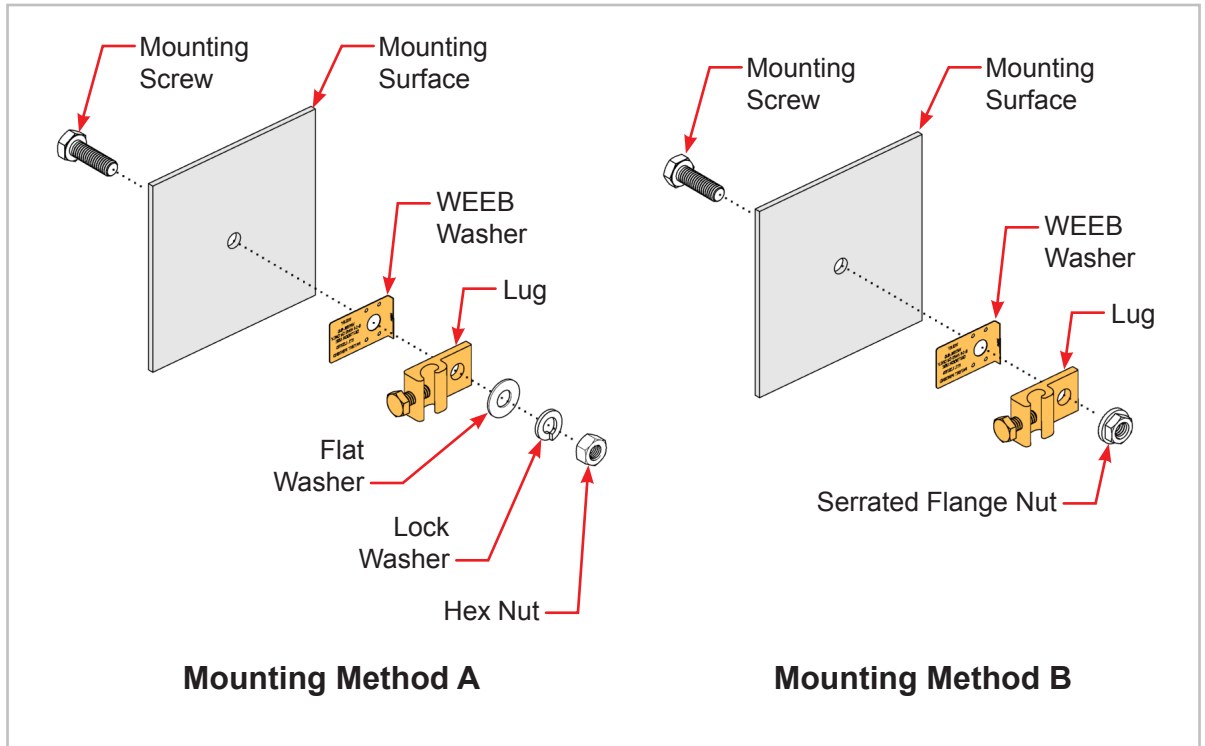

Cat No.	Max OCPD (A)	Mounting Surface					Mounting Screw		Mounting Hole Range	
		Min Profile (w x l)	Min Thick (in)	Max Thick (in)	Mtl	Surface Prep	Size	Tightening torque (lbs.-in)	Min (mm)	Max (mm)
WEEB-LUG-8.0	200	22mm x 20mm	.06"	.25"	AL	Anodized	5/16" M8	120	7.85mm	10mm
			.06"	.25"	Steel	Galvanized				

Table 1: Mounting Surface Requirements

IMPORTANT NOTES

1. Before installing verify with the lug manufacturer for any updates or revisions to these lug installation instructions. The instructions on this page only address the WEEB-LUG-8.0 as found within the manufacturers (Burndy) document number 50016572 Rev E.
2. The NEC section 690.43 states, "Exposed non-current carrying metal parts of module frames, equipment, and conductor enclosures shall be grounded in accordance with 250.134 or 250.136 (A) regardless of voltage."
3. For Proper Equipment Grounding Conductor (EGC) and Overcurrent Protection Device (OCPD) sizing, refer to NEC sections 250.66, 250.122 and 250.166.

Compatible Modules - these modules meet the UL2703 standard

This racking system may be used to ground and/or mount a PV module complying with UL 1703 only when the specific module has been evaluated for grounding and/or mounting in compliance with the included instructions.

Manufacturer	Frame Thickness	Model
Canadian Solar	40 mm	CS6P-250P, CS6P-255P, CS6P-260P, CS6P-260P-SD, CS6P-265P, CS6P-265P-SD, CS6P-270P
Heliene	40 mm	60P-MIM
Kyocera	46 mm	KU250-6BCA, KU255-6BCA, KU260-6BCA, KU265-6BCA
LG	35 mm	LG300N1C-G3, LG305N1C-G3, LG310N1C-G3
	36 mm	LG365N2W-B3, LG375N2W-B3
	40 mm	LG320N1C-G4, LG325N1C-G4, LG 335N1C-G4, LG340N1C-G4
	46 mm	LG375N2W-G4
REC Solar	35 mm	REC265TP, REC270TP, REC275TP, REC280TP, REC285
	38 mm	REC240PE, REC245PE, REC250PE, REC255PE, REC260PE, REC265PE, REC270PE
Silfab	38 mm	SLA260M, SLA265M, SLA270M, SLA275M, SLA280M, SLA285M, SLA290M, SLA295M, SLA300M
Solar World	31 mm	SW280 31mm
	33 mm	SW280, 285, 290, 295, 300 33 mm, SW 320 XL 33mm FR, SW 325 XL 33mm FR, SW 330 XL 33mm FR, SW 335 XL 33mm FR, SW 340 XL 33mm FR, SW 345 XL 33mm FR, SW 350 XL 33mm FR
Suniva	38 mm	OPT-275-60-4-100, OPT-280-60-4-100, OPT-285-60-4-100, OPT-290-60-4-100, OPT-295-60-4-100, OPT-300-60-4-100
Sunpower	46 mm	SPR-327NE-WHT-D, SPR-333NE-WHT-D, X21-335-BLK, X21-345-BLK
Suntech	50 mm	STP270-24/Vd, STP275-24/Vd, STP280-24/Vd, STP285-24/Vd, STP290-24/Vd, STP295-24/Vd, STP300-24/Vd, STP305-24/Vd
Topoint Solar	35 mm	JTM185-72M, JTM190-72M, JTM195-72M, JTM200-72M
Trina	40 mm	TSM-290PD14, TSM-295PD14, TSM-300PD14, TSM-305PD14, TSM-310PD14, TSM-315PD14, TSM-320PD14, TSM-325PD14



Albuquerque Office
1700 Louisiana Blvd., Suite 130
Albuquerque, NM 87110

Corporate Headquarters
660 Beta Drive
Mayfield Village, OH 44143

Telephone: 800.260.3792
Fax: 505.889.3548
www.preformed.com
E-mail: info@plpsolar.com

© 2017 Preformed Line Products
PCN 082417-1 Version 1, Rev A
SP3459