

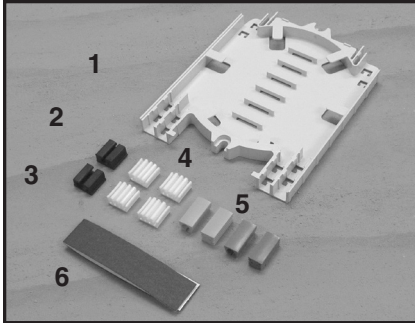

# COYOTE® LITE-GRIP® Splitter Splice Trays

Be sure to read and completely understand this procedure before applying product. Be sure to select the proper PREFORMED™ product before application.

## NOMENCLATURE



**LITE-GRIP Splitter Tray for 1x8 and 1x16 Connectorized Splitters (P/N: 800013707)**

1. LITE-GRIP Splitter Tray (1)
2. LITE-GRIP Splitter Block for 1x8 Connectorized Splitter
3. LITE-GRIP Splitter Block for 1x16 Connectorized Splitter
4. Yellow LITE-GRIP Splice Block for Single Fusion Splices (4)
5. LITE-GRIP Sleeves (4)
6. Felt Strip

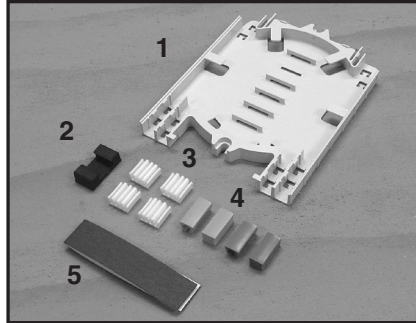

**LITE-GRIP Splitter Tray for 1x32 Connectorized Splitters (P/N: 800013708)**

1. LITE-GRIP Splitter Tray (1)
2. LITE-GRIP Splitter Block for 1x32 Connectorized Splitter
3. Yellow LITE-GRIP Splice Block for Single Fusion Splices
4. LITE-GRIP Sleeves (4)
5. Felt Strip

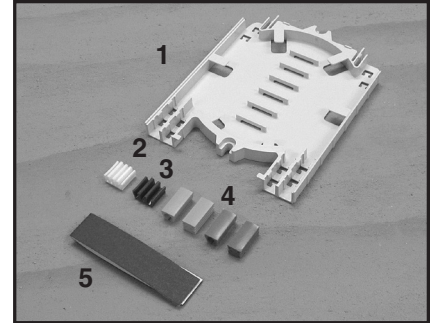

**LITE-GRIP Splitter Tray Standard Splitters and 1x4 Connectorized Splitters (P/N: 80808524)**

1. LITE-GRIP Splitter Tray (1)
2. Yellow LITE-GRIP Splice Block for Single Fusion Splices (1)
3. Purple LITE-GRIP Splice Block for Ribbon Splices(4)
4. LITE-GRIP Sleeves (4)
5. Felt Strip

**Step #1** Press tabs located at top of tray inward and rotate cover upward to remove.

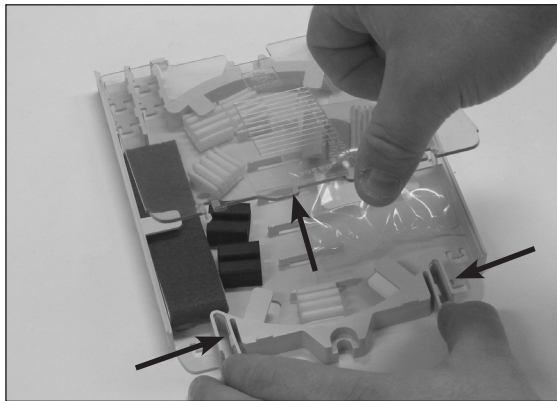

**Step #2** Insert fiber into required slot(s) of LITE-GRIP Sleeve.

### 6 Slot LITE-GRIP Sleeve

**Accepts:**

- (6) 2 mm jacketed fiber or small diameter buffer tubes – up to .100" (2.5 mm) diameter.

Or

- (4) 3 mm jacketed fiber or buffer tubes – greater than .100" (2.5 mm) diameter.

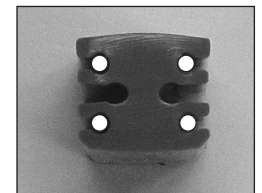
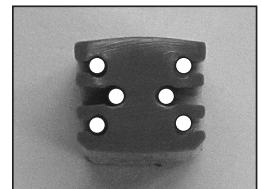

## Step #2 Continued

### 1 Slot LITE-GRIP® Sleeve

#### Accepts:

- (1) transport tube – .250" (6.35 mm) O.D.
- (1) transport tube – .170" (4.32 mm) O.D. with 1 wrap of felt.
- (1) transport tube – .135" (3.43 mm) O.D. with 2 wraps of felt.

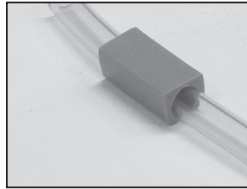

Or

- (1) bundle of (6) 3 mm jacketed fibers with 1 wrap of felt.
- (1) bundle of (12) 2 mm jacketed fibers with 1 wrap of felt.

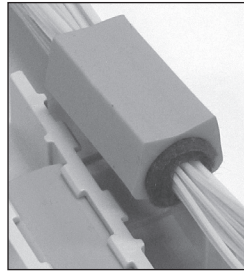

- Step #3** Insert LITE-GRIP Sleeves into entry channel with angled edge down. Confirm that each sleeve is inserted between the guide ribs and captured under the tension tabs.

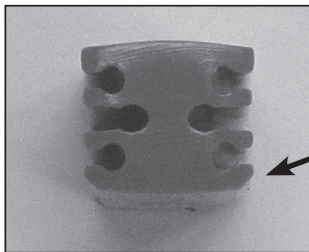

Angled Edge

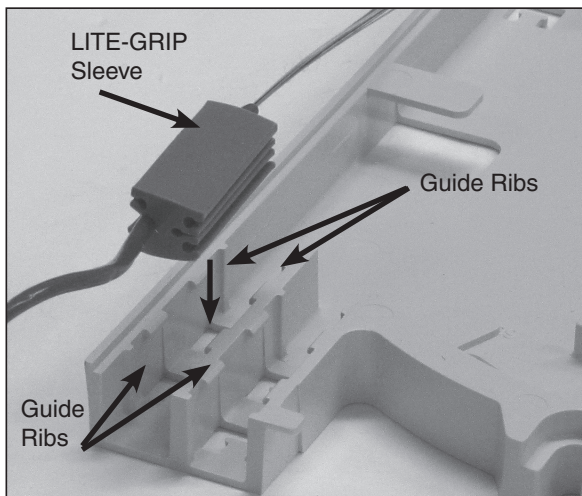

## Step #3 Continued

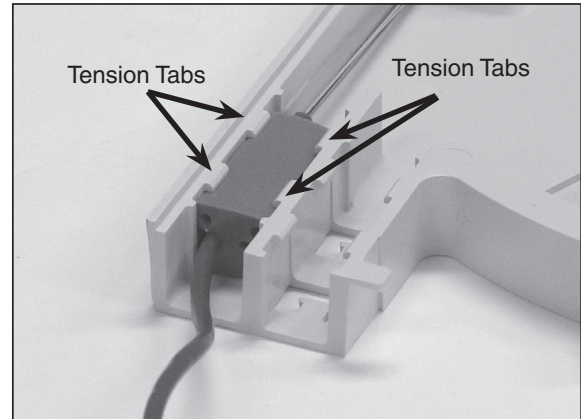

- Step #4** If tie wraps are required, wrap fiber with blue felt and secure with tie wraps.

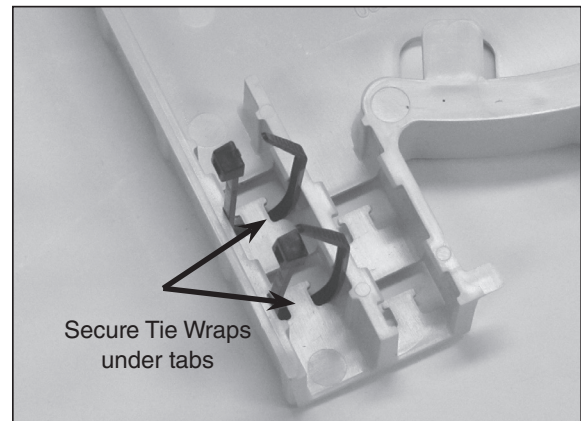

- Step #5a** Insert LITE-GRIP splice blocks between guide ribs and confirm that the edges of each LITE-GRIP splice block are captured within the slots of the guide ribs.

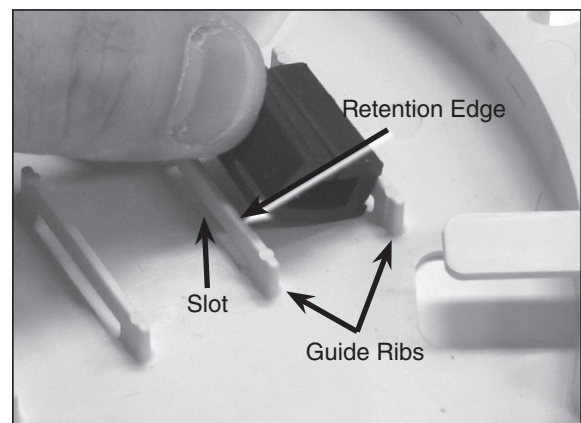

**Step #5b** Insert LITE-GRIP® splitter blocks in the top position(s) of the tray.

**1x8 or 1x16 Splitter Block Installed in Top Position**

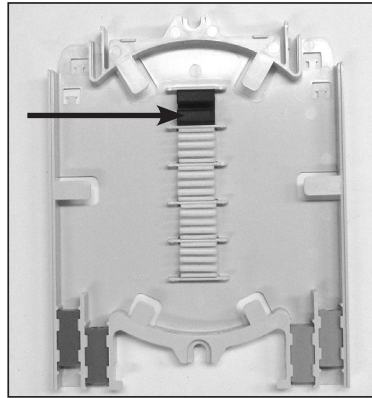

**1x8 or 1x16 Splitter Block Installed in Top 2 Position**

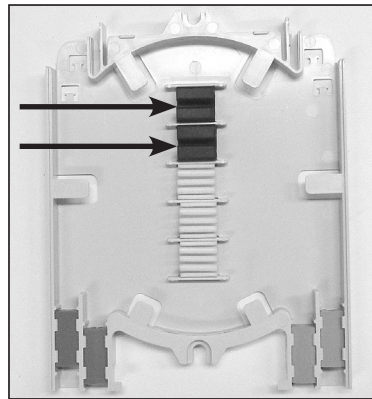

**1x32 Splitter Block Installed in Top Position**

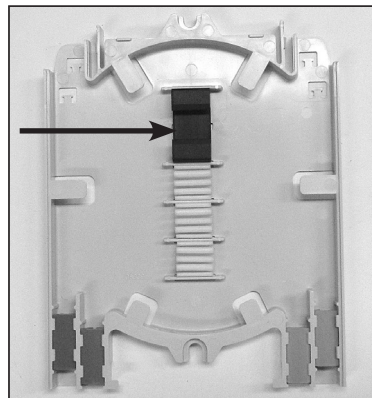

**Purple 3-Hole LITE-GRIP Splice Block for 1x4 Splitter Installed in Top Position**

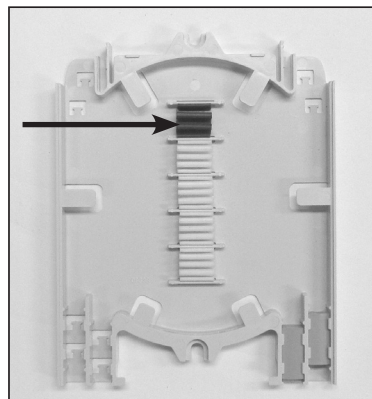

**Step #6** Install splitter into the LITE-GRIP Splitter Block

**1x8 Splitter Installed in Splitter Block**

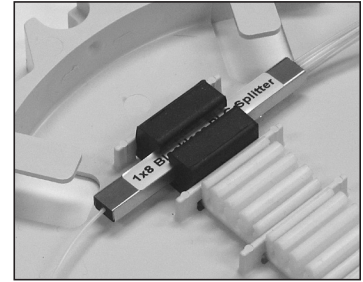

**1x16 Splitter Installed in Splitter Block**

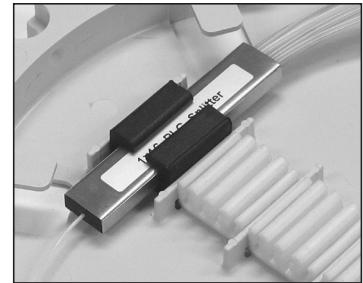

**1x32 Splitter Installed in Splitter Block**

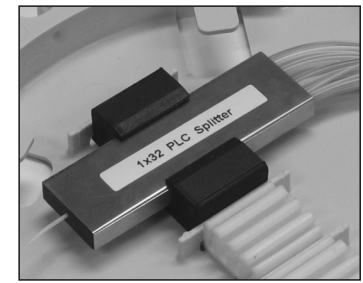

**1x4 Splitter Installed in Purple 3-Hole Splice Block**

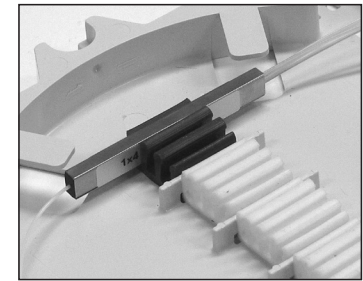

**Step #7** Incoming Fiber Routing

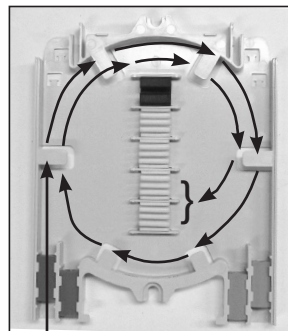

Incoming Fiber from Buffer Tube or Transport Tube

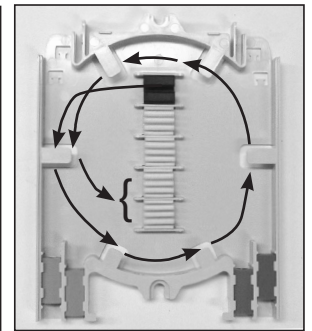

Incoming Fiber from Splitter

**Step #8a** Splice per your accepted company practice.

**Step #8b** Insert splices in yellow 8-hole splice blocks for single fusion splices as follows:

**2 Splice Configuration**

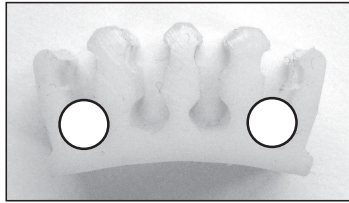

**4 Splice Configuration**

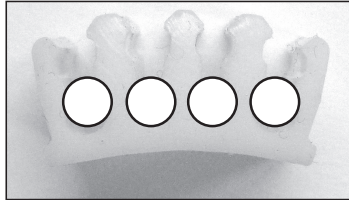

**6 Splice Configuration**

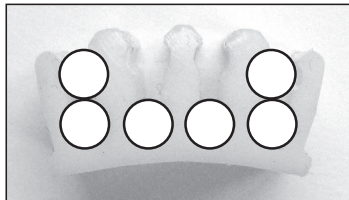

**8 Splice Configuration**

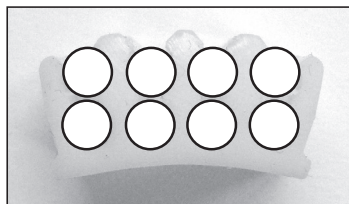

**Step #9** Outgoing Fiber Routing

**Pigtails Exiting Splitter**

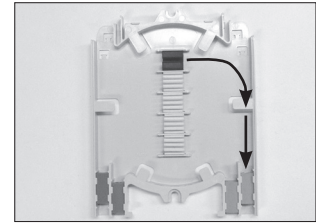

**Step #10a** Bundle exiting pigtails with felt in between the guide ribs of the entry channel.

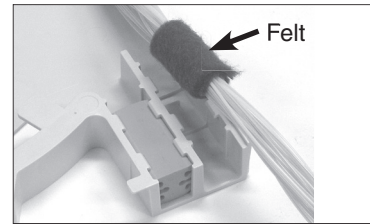

**Step #10b** Place a One Slot LITE-GRIP® Sleeve over the felt and insert the sleeve into the entry channel with angled edge down. Confirm that each sleeve is inserted between the guide ribs and captured under the tension tabs.

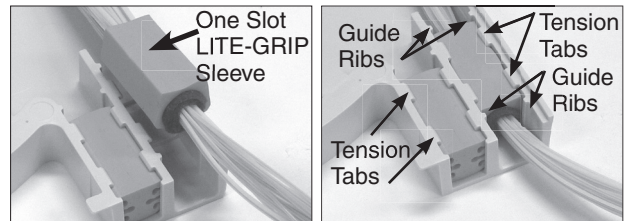

## SAFETY CONSIDERATIONS

This application procedure is not intended to supersede any company construction or safety standards. This procedure is offered only to illustrate safe application for the individual. **FAILURE TO FOLLOW THESE PROCEDURES MAY RESULT IN PERSONAL INJURY OR DEATH.**

**Do not modify this product under any circumstances.**

This product is intended for use by trained technicians only. **This product should not be used by anyone who is not familiar with, and not trained to use it.**

When working in the area of energized lines, extra care should be taken to prevent accidental electrical contact.

For proper performance and personal safety, be sure to select the proper size PREFORMED™ product before application.

PREFORMED products are precision devices. To ensure proper performance, they should be stored in cartons under cover and handled carefully.



# PREFORMED LINE PRODUCTS

P.O. Box 91129, Cleveland, Ohio 44101 • 440.461.5200 • www.preformed.com • e-mail: inquiries@preformed.com

SP3109-1