

PREFORMED™ Deadend Grip



For AAC, AAAC, and Limited Tension on Large Ø ACSR



Part Number	Conductor Stranding	Conductor Diameter (mm)	Colour Code
AFG-053	7/1.75	5.25	Purple
AFG-063	7/2.11	6.33	Yellow
AFG-068	7/2.25	6.75	Brown
AFG-075	7/2.50	7.50	Blue
AFG-083	7/2.75	8.30	White
AFG-090-CL	7/3.00	9.00	Red
AFG-102-CL	7/3.40	10.20	Purple
AFG-105	7/3.50	10.50	Blue
AFG-113-CL	7/3.75	11.25	Black
AFG-118-CL	19/2.36	11.80	Brown
AFG-135-CL	7/4.50	13.50	Green
AFG-143-CL	7/4.75	14.30	Blue
AFG-163-CL	19/3.25	16.30	Orange
AFG-169-CL	19/3.38	16.90	Orange
AFG-175-CL	37/2.50	17.50	Blue
AFG-188-CL	19/3.75	18.80	Black
AFG-210-CL	37/3.00	21.00	Red
AFG-232-CL	19/4.65	23.25	Green
AFG-240-LT-CL	19/4.75	23.80	Blue
AFG-263-LT-CL	37/3.75	26.30	Black

Contact PLP for other sizes.

LT = Denotes Limited Tension only (85% UTS of AAC and 65% of AAAC & ACSR Conductors)

CL= Denotes Cable Loop

For SC/AC Conductors
Left Hand Lay Standard



Part Number	Conductor Stranding	Conductor Diameter (mm)	Colour Code
AWFG-K023	3/2.75	5.91	White
AWFG-K032	3/3.25	6.98	Orange
AWFG-K040	3/3.75	8.06	Black
AWFG-K050	7/2.75	8.25	White
AWFG-K060-8	7/3.05	9.15	Red
AWFG-K070	7/3.25	9.75	Orange
AWFG-K088	7/3.75	11.25	Black
AWFG-K106	7/4.25	12.75	Brown
AWFG-K136	19/2.75	13.75	White

Note: Contact PLP for deadends to suit right hand lay conductors.



Application Procedure & Safety Considerations

P R E F O R M E D L I N E P R O D U C T S

Single-Piece Grips for AAC, AAAC, ACSR, SC/AC, SC/GZ and Copper Conductors

Completely read and understand this procedure before applying products. Special attention should be given to the Safety Considerations located on the last page. We advise the reader to review those considerations now, and then again during the general review of this procedure

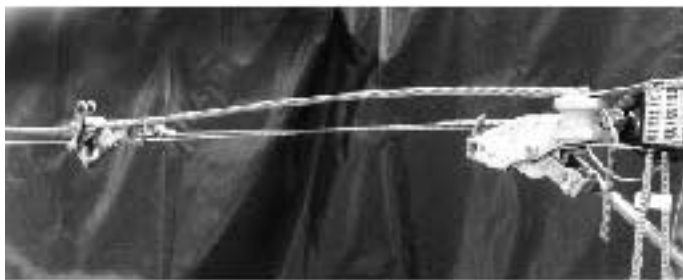

- 1) Select the correct grip for your application. Tension the conductor and fit the required insulator and thimble.



- 2) Place the grip through the thimble or around the insulator and while applying a light tension and holding the fitting legs together, lay it against the conductor.





- 3) Grasp both fitting legs evenly and apply onto the conductor at the crossover mark, making sure the gap between them is approximately the same.

NOTE: Grips are made the same lay as the conductor, therefore application rotation will be right hand for right hand conductors and vice versa for left.



- 4) Working both legs together and pulling away from the conductor, fully wrap on the fitting and snap in the ends.
- 4a) On large fittings it may be necessary to pull away from the conductor at a larger angle when applying the grip. In these cases care must be taken not to distort the fitting.



Completed Application

- 6) If difficulty is experienced applying the last couple of pitches, the legs may be further split to allow easier snapping onto the conductor. Do not use pliers or screwdrivers as this may damage the conductor strands.

THIMBLE FOR GRIPS

- 1) Loops of the Single Piece Grip are designed for use with spool insulators, clevis thimbles and other smoothly contoured fittings.
- 2) The following styles are considered as suitable.

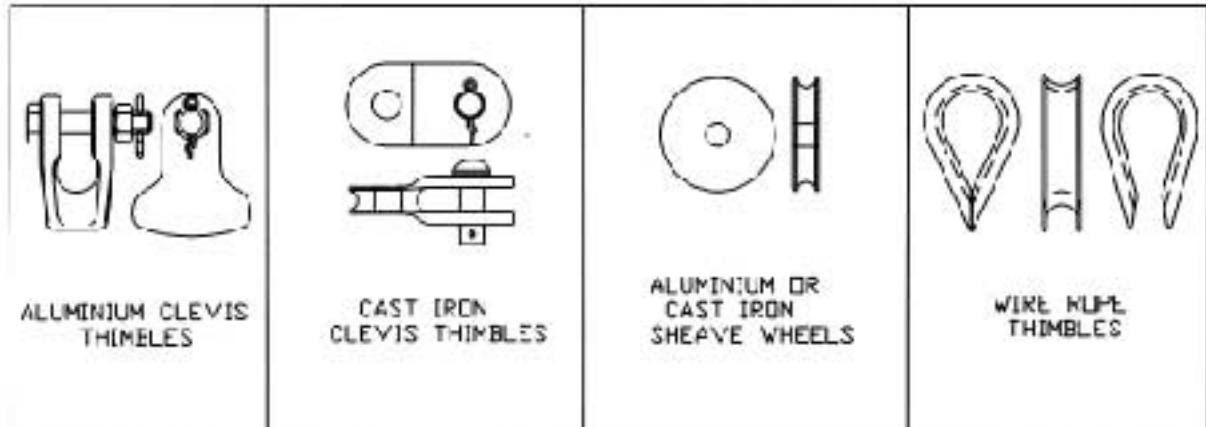

- 3) Avoid dissimilar metals that could promote galvanic corrosion (eg. copper and aluminium).
- 4) PREFORMED Grips may be applied three times on new installations, if sag adjustments are necessary.
- 5) PREFORMED Grips are not to be reused after the final application.

SAFETY CONSIDERATIONS

- 1) For proper performance and personal safety be sure to select the proper size Single-Piece Grips before application.
- 2) Single-Piece Grips are precision devices. To ensure tight assembly, they should be stored in cartons under cover and handled carefully.
- 3) This application procedure is not intended to supersede any company construction or safety standards. This procedure is offered only to illustrate safe application for the individual. Failure to follow these procedures and restrictions may result in personal injury.
- 4) When working in the area of energized lines, extra care should be taken to prevent accidental electrical contact.
- 5) This product is intended for use by trained linesmen only. This product should not be used by any one who is not familiar with and trained in the use of it.



**PREFORMED
LINE PRODUCTS
(AUSTRALIA) PTY LTD**
A.B.N. 27 004 533 877

190 Power st. Glendenning, NSW Australia 2761
PO Box 106, Glendenning Business Centre, NSW Australia 2761
Phone: (02) 8805 0000 Fax: (02) 8805 0090
intl 61 2 8805 0000 intl 61 2 8805 0090

Email: plpaus@preformed.com.au
Web: www.preformed.com.au

NOTES

- 1. ALL DIMENSIONS IN MILLIMETRES.
- 2. TOLERANCES UNLESS OTHERWISE STATED:-
 - a. HOLE DIAMETRE ±0.5mm
 - b. LINEAR DIMS. UP TO 30mm ±1.5mm
 - c. LINEAR DIMS. OVER 30mm ±5% UP TO A MAX. OF 5mm.
- 3. LAY: RIGHT HAND
- 4. MATERIAL: ALUMINIUM ALLOY

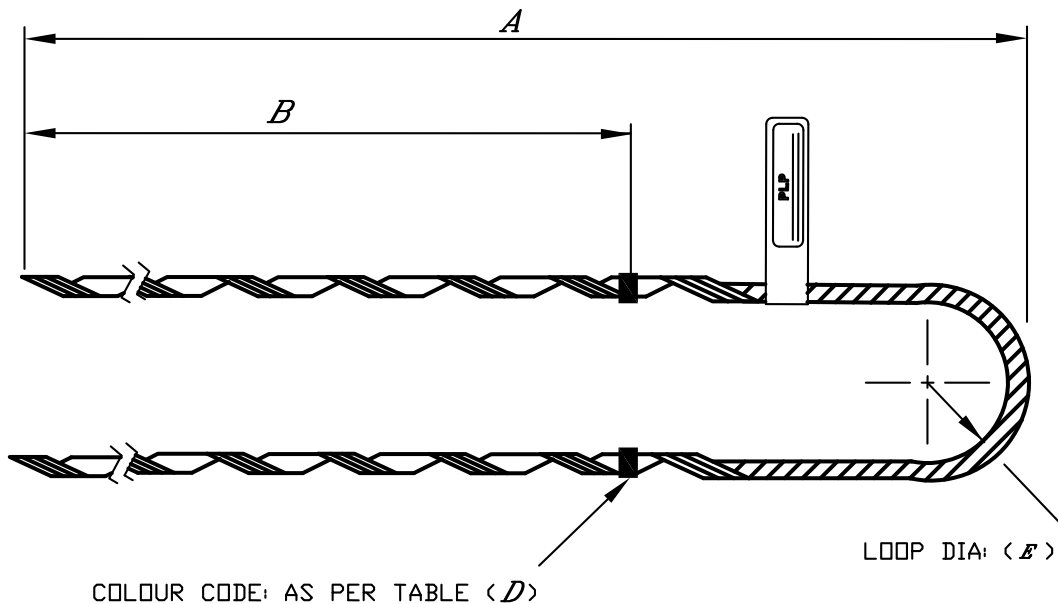

PART NO.	LENGTH (±50) "A"	GRIP LENGTH (±50) "B"	TAPE COLOUR "D"	LOOP DIA. "E"	CONDUCTOR DETAILS "F"	RODS/ SET "G"
AFG-090-CL	640	470	RED	60	7/3.00 MM (0.118") AAC, AAAC	4
AFG-102-CL	690	500	PURPLE	60	7/3.40 MM (0.134") AAC, AAAC	5
AFG-113-CL	790	550	BLACK	60	7/3.75 MM (0.144") AAC, AAAC MINK/RANGD LT. ACSR DC1048	6
AFG-118-CL	800	560	BROWN	60	19/2.36 MM (0.093") AAC	6
AFG-135-CL	920	650	GREEN	60	7/4.50 MM (0.173") AAC, AAAC 110316	5
AFG-143-CL	920	650	BLUE	60	7/4.75 MM (0.186") AAC, AAAC 7/5.00 MM AAAC/1120 COMP IIN06013, DC1050, LM30734	6
AFG-163-CL	880	650	ORANGE	60	19/3.25 MM (0.128") AAC, AAAC, AAAC/1120	6
AFG-169-CL	1150	900	ORANGE	60	RANGE: 16.4-17.0 MM AAC, AAAC 336.4MCM 19W AAC	6
AFG-175-CL	1190	880	BLUE	60	37/2.50 MM (0.102") AAC, AAAC 19/3.65 MM AAAC 1120 COMP	5
AFG-188-CL	1240	880	BLACK	60	19/3.75 MM (0.149") AAC, AAAC 400215	6
AFG-210-CL	1300	900	RED	60	37/3.00 MM (0.118") 19/4.22 MM (0.166") AAC, AAAC	5
AFG-238-CL	1615	1290	BLUE	76	19/4.75 MM AAC, AAAC	6

PRODUCT TAPE COLOUR : AS PER TABLE (D)

CONDUCTOR DETAILS AS PER TABLE (F)		ALUMINIUM GRIP PART NO.: _____ MM/YY WORK ORDER_____
--	--	---

A	PN	19.09.94	L	NA	23.05.11
CHK	DM	19.09.94	CHK	DF	24.05.11
INITIAL ISSUE		A9978			
ERF NO. A0701					

THIS DRAWING IS THE EXCLUSIVE PROPERTY OF PREFORMED LINE PRODUCTS (AUSTRALIA). REPRODUCTION THEREOF IS PROHIBITED AND IS TO BE USED ONLY WITH THE EXPRESSED PERMISSION OF THE COMPANY

PART No: AFG-###-CL		ALUMINIUM GRIP	
PASSED	CC	DATE	31.05.11



PREFORMED LINE PRODUCTS (AUSTRALIA) PTY. LTD.

SCALE	N.T.S.
-------	--------

DRAWING NUMBER
051-039-RD



PLP (AUSTRALIA) PTY LTD
ENGINEERING DEPARTMENT

DATE – 15TH SEPTEMBER, 2017

TYPE TEST REPORT NO: T9751
TEST REFERENCE NO: T17/18
PAGE 1 of 6

MECHANICAL STRENGTH TYPE TEST

ON:

ALUMINIUM GRIP CABLE LOOP & ALUMINIUM SPLICE
7/3.4mm AAC CONDUCTOR

(PLP Aust. Part Nos. – AFG-102-CL & AFS-102)

Testing Officer:  (Jose-elmer Simeon)

Approved by:  (Florian de Celis, Compliance Manager)

Date Approved: 18/09/17

190 Power Street Glendenning NSW 2761 AUSTRALIA
Phone: 8805 0000, INTL (612) 88050000
Fax: 8805 0090, INTL (612) 88050090

THE QUALITY SYSTEM OF PLP AUSTRALIA HAS BEEN CERTIFIED TO
AS/NZS ISO9001:2015 BY GLOBAL MARK REGISTER QUALITY ASSURANCE

Fittings and Accessories for Power and Communication.
Engineered Plastics and Extrusions.
Data Communication Products.