

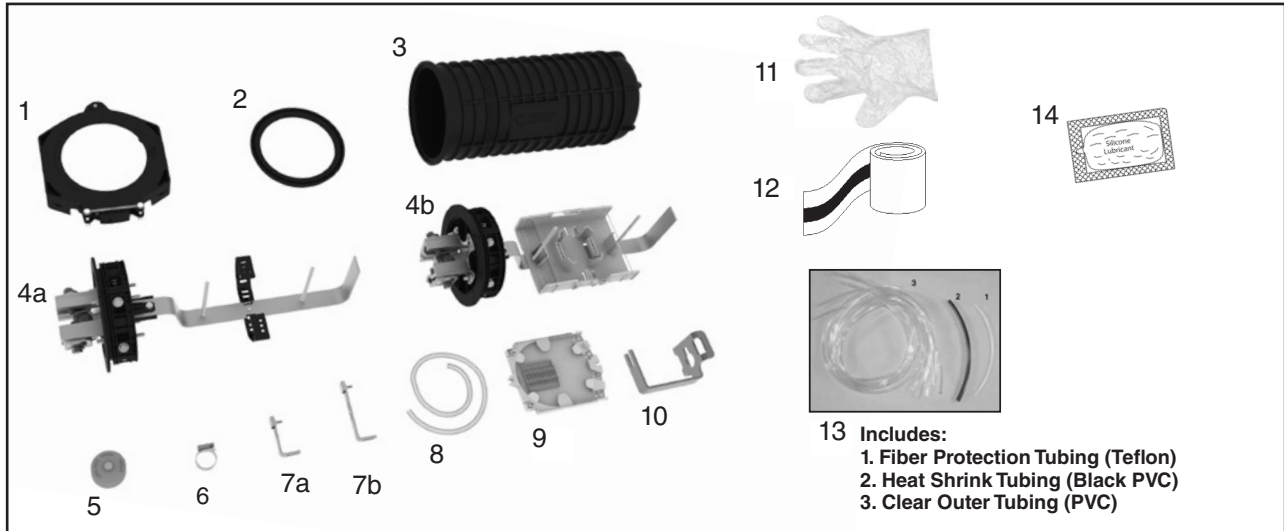

# COYOTE® Dome Closure Cable Restraint Bracket (CRB) System for OPGW 6-1/2" x 17" and 6-1/2" x 22"

Be sure to read and completely understand this procedure before applying product. Be sure to select the proper PREFORMED™ product before application.



### NOMENCLATURE

- 1. Dome collar (1)
- 2. Dome gasket (1)
- 3. Dome cover (1)
- 4a. Organizer with 4-port end plate for plastic buffer tube and cable restraint bracket (CRB) (1)
- 4b. Organizer with 4-port end plate for SS buffer tube and cable restraint bracket (CRB) (1)
- 5. Cable grommets (2)
- 6. Hose clamps (4)

- 7a. Short strength member bracket (2)
- 7b. Long strength member bracket (2)
- 8. Transport tubing kit (1) (In dome kits for SS buffer tube applications)
- 9. Splice tray (1)
- 10. Mounting adapter bracket (1)
- 11. Disposable glove (1)
- 12. Green sealant (12")
- 13. Transition Furcation Kit (1) for Stainless Steel buffer tube applications
- 14. Silicone lubricant (4-five gram packets)

### TOOLS REQUIRED

- 3/8" & 7/16" can wrench or socket
- 1/4" nut driver or screwdriver
- Snips
- Fiber optic cable opening tools
- Torque wrench with 9/16" socket

**Table 1: COYOTE Dome Closure CRB System For OPGW 6.5" x 17" and 6.5" x 22" Kit Contents and Accessories**

Catalog Number	Description
<b>Dome Kits for Plastic Buffer Tube Application</b>	
COYW617P001	<b>6.5" x 17" COYOTE® DOME Closure CRB for OPGW with Plastic Buffer Tubes.</b> Kit includes (1) Splice Tray, (1) Organizer for Plastic Buffer Tubes and Cable Restraint Bracket and (1) Mounting Adapter,** (1) OPGW Green Sealant Kit, (6) Grommets.
COYW622P001	<b>6.5" x 22" COYOTE Dome Closure CRB for OPGW with Plastic Buffer Tubes.</b> Kit includes (1) Splice Tray, (1) Organizer for Plastic Buffer Tubes and Cable Restraint Bracket and (1) Mounting Adapter,** (1) OPGW Green Sealant Kit, (6) Grommets for cable ranging .35"-.75".
<b>Dome Kits for Stainless Steel Buffer Tube Application</b>	
COYW617S001	<b>6.5" x 17" COYOTE® DOME Closure CRB for OPGW with Stainless Steel Buffer tubes.</b> Kit includes (1) Splice Tray, (1) Organizer for SS buffer tubes and Cable Restraint Bracket (CRB), (1) Mounting Adapter**, (1) OPGW Green Sealant Kit and (6) Grommets, and Furcation Kits
COYW622S001	<b>6.5" x 22" COYOTE® DOME Closure CRB for OPGW with Stainless Steel Buffer tubes.</b> Kit includes (1) Splice Tray, (1) Organizer for SS buffer tubes and Cable Restraint Bracket (CRB), (1) Mounting Adapter**, (1) OPGW Green Sealant Kit and (6) Grommets, and Furcation Kits
<b>Splice Trays</b>	
80806033	Standard Short Tray, 12 splice count for 6.5" x 17" Dome
80805514	Standard Long Tray, 36 splice count for 6.5" x 22" Dome









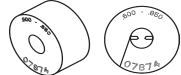

\*\*COYOTE Dome Kits include a Mounting Adapter that can vertically mount the dome directly to wood poles or band to metal poles. The modular design of the mounting adapter can be mounted to the FIBERLIGN® CABLE Storage 2 and COYOTE Defender 2 as well.

**Table 1: COYOTE® Dome Closure CRB System For OPGW 6.5" x 17" and 6.5" x 22" Kit Contents and Accessories**

Description	
<b>Catalog Number</b>	<b>Transition Furcation Kits for Stainless Steel Buffer Tubes</b>
800011212	Furcation Kit for SS buffer tubes O.D. range .133"-.154"
800011381	Furcation Kit for SS buffer tubes O.D. range .118"-.126"
800011382	Furcation Kit for SS buffer tubes O.D. range .102"-.110"
800011563	Furcation Kit for SS buffer tubes O.D. range .063"-.098"
<b>Catalog Number</b>	<b>OPGW Cable Prep and Fiber Materials</b>
80812321	CRB System OPGW Green Sealant Kit and Attachment kit, includes long and short strength member brackets
8003509	60 mm Heat Shrink Splice Protectors, 12 pack
8003280	Transition Tube Kit, (protects fiber routed from SS buffer tube to transition tray)
80805293	Transport Tube Kit, (protects fiber routed from transition tray to splice trays)
<b>Catalog Number</b>	<b>Cable Storage and Ballistic Protection**</b>
80061195	FIBERLIGN® CABLE Storage 2 for OPGW, 60" Loop
80061194	COYOTE® Defender 2 for 6.5" x 17" and 6.5" x 22" Dome



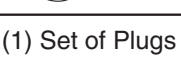

\*\*COYOTE Dome Kits include a Mounting Adapter that can vertically mount the dome directly to wood poles or band to metal poles. The modular design of the mounting adapter can be mounted to the FIBERLIGN® CABLE Storage 2 and COYOTE Defender 2 as well.

**Table 2: COYOTE® Grommet Chart**

PLP Catalog Number	Cable Range Inches (mm)	Description	Splitting Location
8003409	.30 - .43 (8 - 11 mm)	1-entry grommet	
8003691	.40 - .60 (10.16 - 15 mm)	1-entry grommet	
8003692	.60 - .85 (15 - 22 mm)	1-entry grommet	
8003693	.85 - 1.0 (22 - 25 mm)	1-entry grommet	
8003694	1.0 - 1.25 (25 - 32 mm)	1-entry grommet	
8003663	.40 - .60 (10.16 - 15 mm)	2-entry grommet	
8003990	.50 - .60 (12.7 - 15.2) .125 - .25 (3.2 - 6.4) and flat drop	4-entry grommet	
8003664	.30 - .43 (8 - 11 mm)	4-entry grommet	
8004065	.250 - .312 (6.4 - 7.9 mm)	4-entry grommet	
8003665	.125 - .25 (3 - 6 mm) and flat drop cable	6-entry grommet	
8003676	.42 - .60 (11 - 15 mm), .125 - .25 (3 - 6 mm), and flat drop cable	7-entry grommet	

**NOTE:** Grommet Kit contains (1) Grommet, (1) Cable Measure Tape, (2) Silicone Lubricant Packs, (1) Set of Plugs (Multi-Entry Grommets only)

**Table 3: COYOTE® Dome Closure CRB System For OPGW Application Guide**

COYOTE Dome Catalog Number	Max. Fiber Count	COMMON OPGW CONSTRUCTION TYPES			
		Central Aluminum Tube with Plastic Buffer Tube	Slotted Core with Plastic Buffer Tube	Stranded with Stainless Steel Buffer Tube	Central Aluminum Tube with or without Stainless Steel Buffer Tube
					
COYW617P001	48	X	X		
COYW622P001	144	X	X		
COYW617S001	48			X	X
COYW622S001	144			X	X

\*Catalog Code COYWxxxzyzzz, COYW = COYOTE® Dome for OPGW, x = Closure size, y = buffer tube type (P or S) and z = kit no. (standard = 001)

**Splice Tray Guide for Standard Dome Kits**

Splice Tray Catalog Number	Splices Per Tray	USED WITH DOME CATALOG NO. KIT			
		COYW617P001 (6.5" x 17")	COYW622P001 (6.5" x 22")	COYW617S001 (6.5" x 17")	COYW622S001 (6.5" x 22")
80806033	12	X		X	
80805514	36		X		X

## End Plate Preparation

**Step #1** Remove support bar mounting clip from organizer assembly.

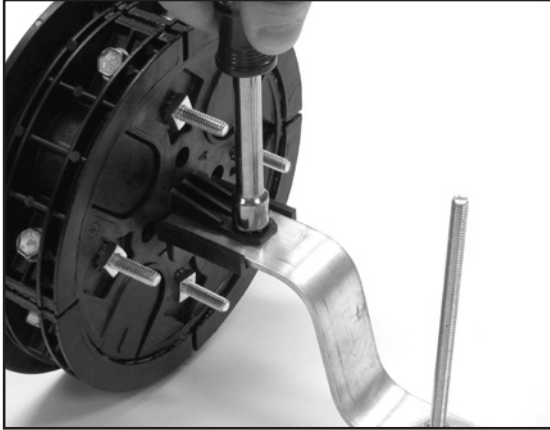

**Step #2** Remove end plate from organizer assembly.

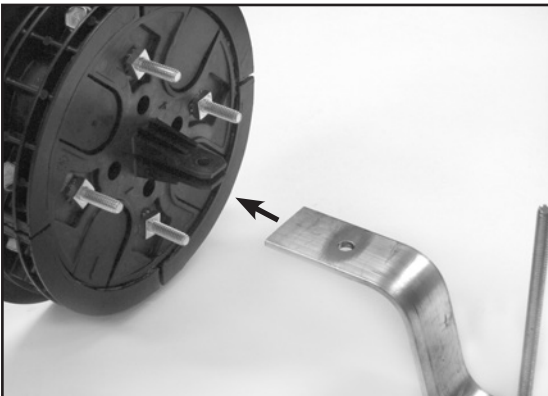

**Step #3** Remove the end plate caps from the selected cable ports and break out the tabs.

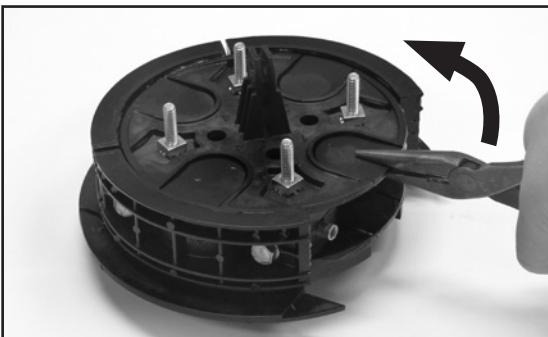

**PLP TIP:** Scoring edges of tabs with knife makes them break out easier.

**PLP TIP:** For ease of breaking out the tabs, it is recommended to remove the Cable Restraint Bracket (CRB) from the end plate first.

**Step #4** Reassemble organizer assembly to end plate with mounting clip and 1/4" hex bolt and nut.

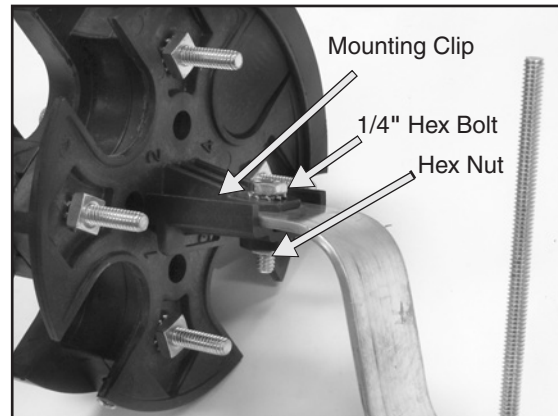

## Cable Preparation

**Step #5** Measure the OPGW cable to determine the diameter of the proper grommet to be used.

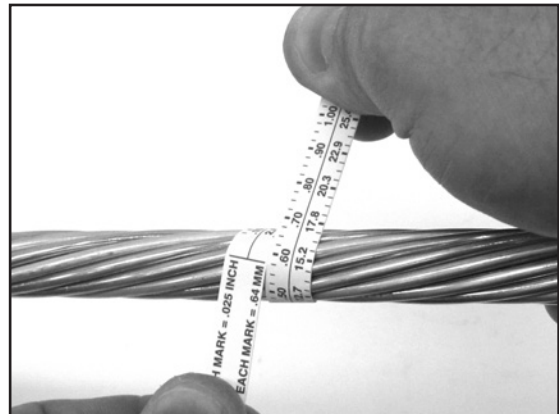

**Step #6** Insert OPGW cable through the grommet.

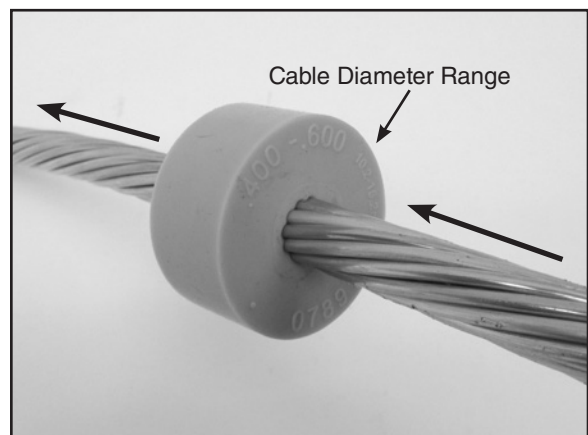

**Step #7** Measure and mark the outer strands of the OPGW cable a minimum of 77" (2.0 m) or 82" (2.1 m) from the end of the cable depending on the size of the closure.

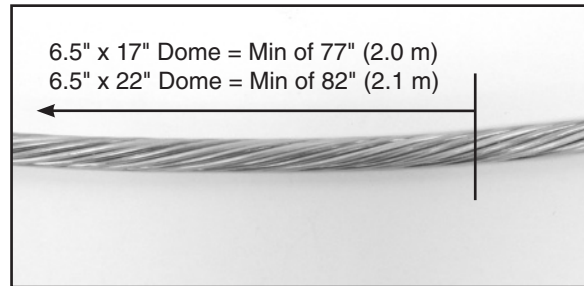

**Step #8** Remove the outer strand layer of the OPGW at the marked location. If there are multiple outer layers, place a mark on each layer of strand where the previous layer has been cut. Remove strands by recommended practice of supplier, which may include scoring the strands with a file or thin cutting wheel to weaken the strands before snapping them off.

**CAUTION:** Wear eye protection, protective clothing, and safety gloves while removing strands to avoid injury.

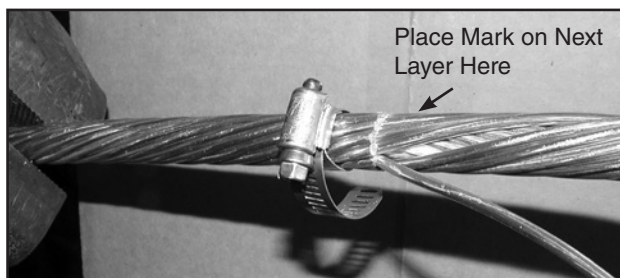
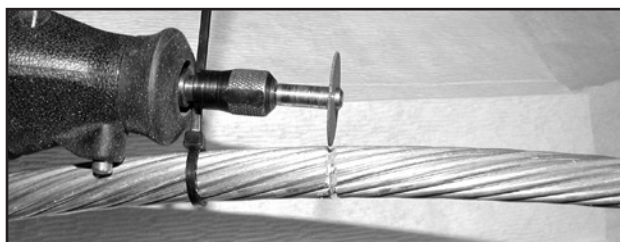

**Step #9** Determine which type of OPGW is being used.

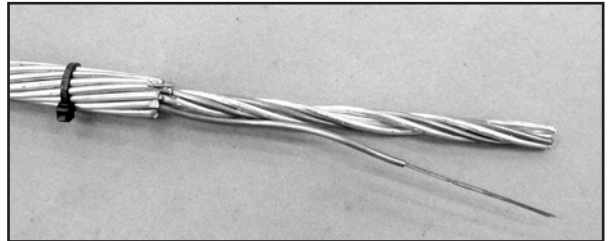

**Type 1: OPGW with Stranded Stainless Steel (Ridged) Buffer Tube**

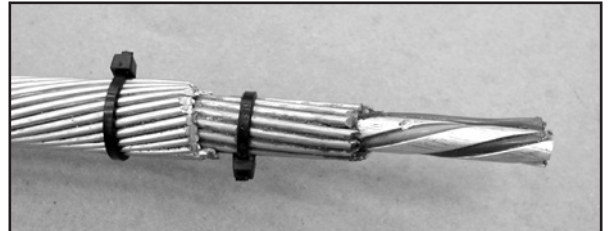

**Type 2: OPGW with Slotted Core with Flexible Plastic Buffer Tubes**

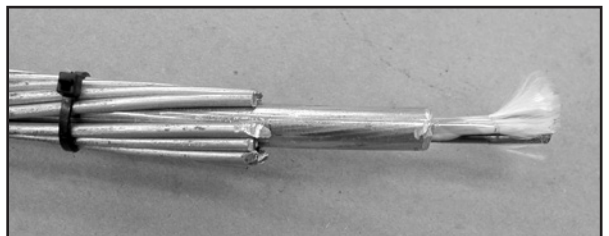

**Type 3: OPGW with Central Aluminum Tube with Flexible Plastic Buffer Tube**



**Type 4: OPGW with Central Aluminum Tube with or without Central Stainless Steel (Ridged) Buffer Tube – This is similar to Type 3 but optical fibers are housed in a central aluminum tube or a single stainless steel buffer tube within a central aluminum tube**

**Step #10** Mark the inner layer (central layer) according to which type of OPGW is being used.

**Type 1 OPGW [Stranded Stainless Steel (Ridged) Buffer Tube]:** Mark all aluminum strands and stainless steel buffer tubes at the cut ends of the outer strands. Place a second mark 1-1/2" (38 mm) away from the cut ends of the outer strands.

**Type 2 OPGW [Slotted Core with Flexible Plastic Buffer Tube]:** Mark the slotted core at the cut ends of the outer strands.

**Type 3 OPGW [Aluminum Tube with Flexible Plastic Buffer Tube]:** Mark the core at the cut ends of the outer strands.

**Type 4a OPGW [Aluminum Tube Core with Stainless Steel Buffer Tube]:** Mark the aluminum tube at the cut ends of the outer strands.

**Type 4b OPGW [Aluminum Tube Core without Stainless Steel Buffer Tube]:** Mark the aluminum tube 1-1/2" (38 mm) from the cut ends of the outer strands.

**Step #11** Place a stainless steel clamp (provided in kit) approximately 18" from the cut ends of the outer strand layers.

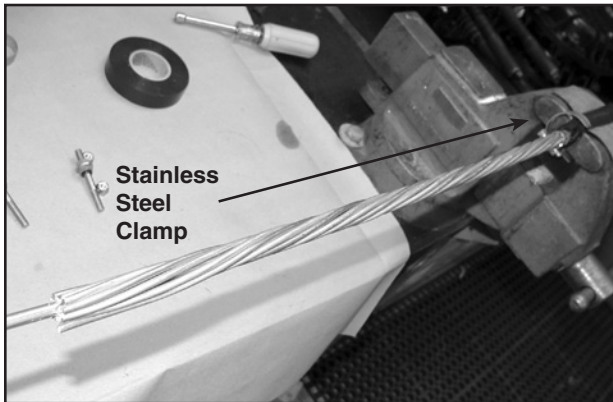

**Step #12** Place a stainless steel clamp (provided in kit) approximately 18" from the cut ends of the outer strand layers.

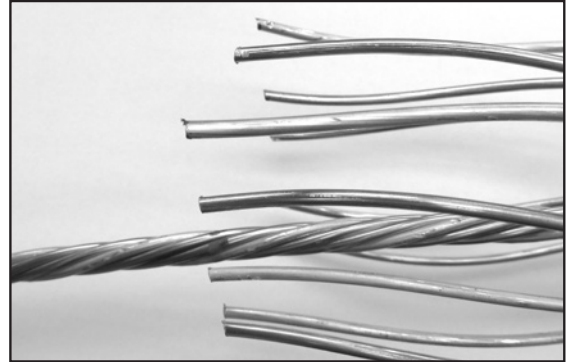

**PLP TIP:** For multi-Layer applications, strands from each layer can be grouped into 3 or 4 strands and gently taped back to provide easier access to subsequent layers and the fiber optic unit.

**Step #13** Remove the inner layer (central layer) components as follows:

**Type 1 OPGW:** Cut and remove all aluminum strands at the mark placed at the cut ends of the outer strands. Mark and cut the central strength member 1-1/4" (32 mm) away from the mark placed at the cut ends of the outer strands.

**OPTIONAL:** The stainless steel buffer tubes may be removed at this time at the mark placed 1-1/2" (38 mm) away from the cut ends of the outer strands. Doing this at this point may be preferred to allow clearance for a cutter tool. Follow the cable suppliers recommended practice for removing the buffer tubes. Once the buffer tubes have been removed, make sure that the exposed fibers are well protected while finishing the preparation of the cable.

**Type 2 OPGW:** Remove the flexible plastic buffer tubes from the slotted core and cut the aluminum core at the mark placed at the cut ends of the outer strands.

**Type 3 OPGW:** Remove the aluminum tube at the mark placed at the cut ends of the outer strands. Braid roughly 3" (72 mm) of the aramid yarn central strength member.

**Type 4a OPGW [Aluminum Tube Core With Stainless Steel Buffer Tube]:** Cut and remove the aluminum tube at the mark placed at the cut ends of the outer strands. Mark the central stainless steel or hard plastic buffer tube within the aluminum tube 1-1/2" (38 mm) away from the cut end of the aluminum tube.

### Step #13 Continued

**OPTIONAL:** The stainless steel buffer tubes may be removed at this time at the mark placed 1-1/2" (38 mm) away from the cut end of the aluminum tube. Doing this at this point may be preferred to allow clearance for a cutter tool. Follow the cable suppliers recommended practice for removing the buffer tube. Once the buffer tube has been removed make sure that the exposed fibers are well protected while finishing preparing the cable.

**Type 4b OPGW [Aluminum Tube Core Without Stainless Steel Buffer Tube]:** Cut and remove the aluminum tube at the mark placed 1-1/2" (38 mm) from the cut ends of the outer strands. Once the aluminum tube has been removed make sure that the exposed fibers are well protected while finishing preparing the cable.

**Step #14** Place a mark on the central strength member/core or aluminum tube where the cut ends of the outer strands are located. If the central tube has been cut at this location, a mark is not required. Place a second mark 2-1/4" (57mm) inward from the marked location of the cut ends of the outer strands for OPGW Type 1, 2, and 4 (a&b) or 2-3/8" (60mm) for OPGW Type 3. Place one wrap of green sealant on either side of the mark leaving roughly 1/8" (3 mm) gap between the wraps.

OPGW Types 1, 2 & 4 (a&b) = 2-1/4" (57 mm)  
OPGW Type 3 = 2-3/8" (60 mm)

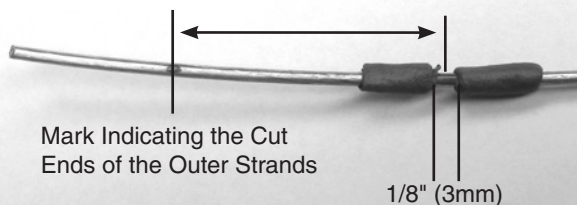

**NOTE:** For Type 2 OPGW, knead the green sealant into the slotted area before replacing the plastic buffer tubes.

**Step #15** For single layer OPGW cables, rewrap the outer layer of strands over the green sealant. Move the hose clamp that was previously placed on the cable about 1/2" (13 mm) from the green sealant area. Place a second hose clamp about 1/2" from the other side of the green sealant area. Tighten both hose clamps so that the green sealant squeezes between the strands.

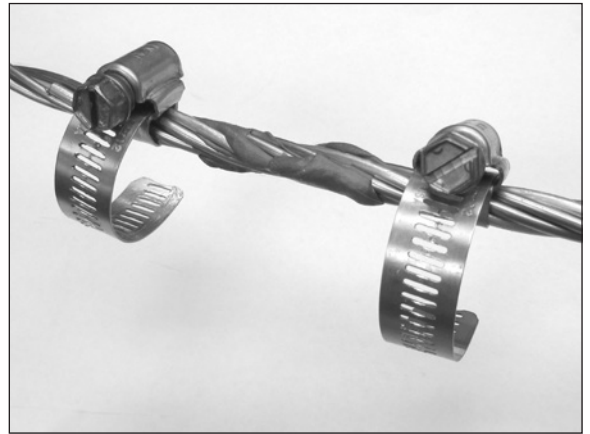
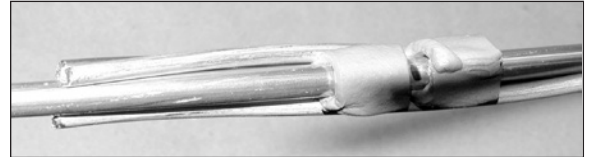

**Step #16** Feather and knead the sealant around the outer strands to form a watertight barrier to prohibit water migration through the cable.

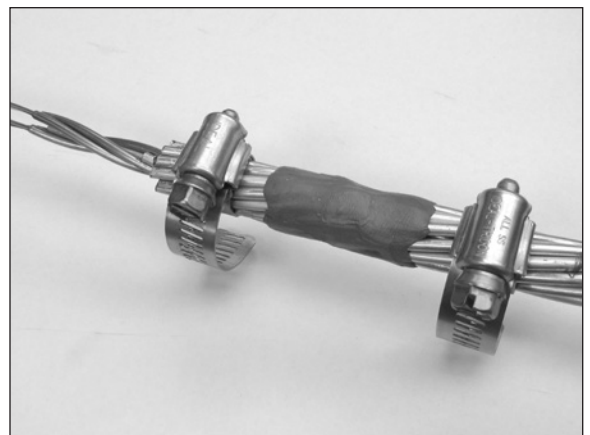

**Step #17** If the OPGW cable has multiple outer strand layers, apply the green sealant to each strand layer and squeeze the sealant through the strands using the hose clamps as in Step 15. Feather and knead the green sealant between each layer. If needed, apply an additional small amount of green sealant between each layer if not enough green sealant squeezed through from the previous layer. To help keep each strand layer from unwrapping, wrap each layer with a couple wraps of electrical tape near the cut ends of each layer.

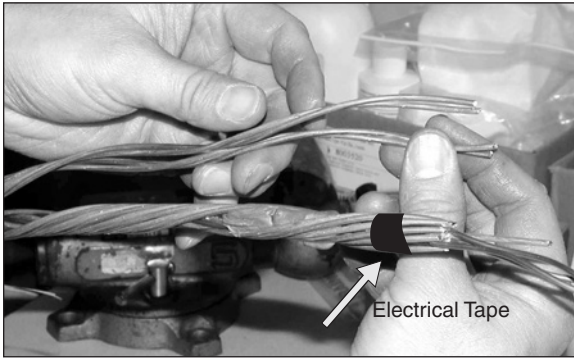

**Step #18** Remove the hose clamps from the outer strand layer. Wrap the outer strand layer a distance of 3-1/2" (89 mm) for **OPGW Types 1, 2 & 4 (a&b)** and 3-5/8" (92 mm) for **OPGW Type 3** from the cut strand ends with electrical tape.

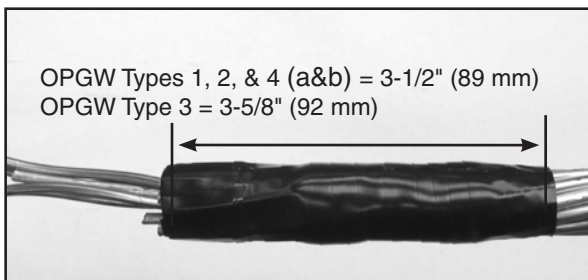

## Installation of Strength Member Bracket On To OPGW Cable

**Step #19** For **OPGW Types 1, 2 & 4 (a&b)** use the short strength member brackets. For **OPGW Type 3** use the long strength member brackets.

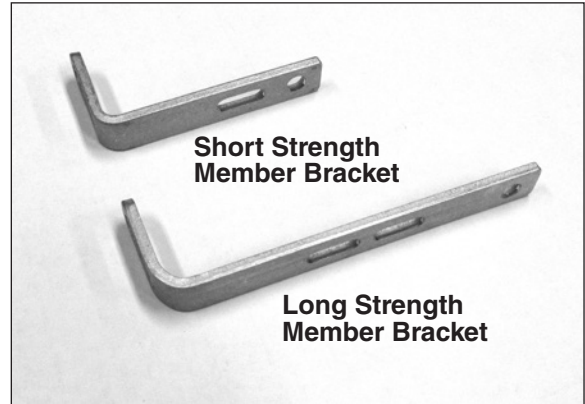

**Step #20** Install the cap on the strength member bracket.

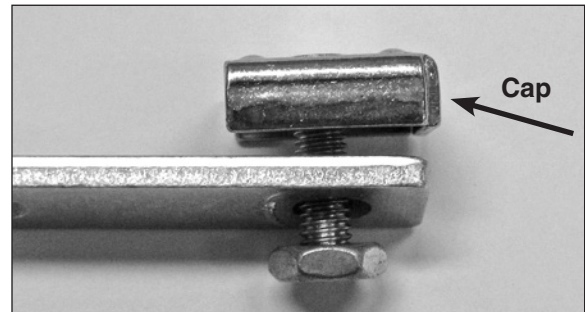

**Step #21** For OPGW Type 1 cables, position the strength member under the cap of the strength member bracket and tighten the nut of the cap to secure. For OPGW Type 3 cables, wrap the aramid yarn clockwise around the stud under the cap of the strength member bracket and tighten the nut of the cap to secure.

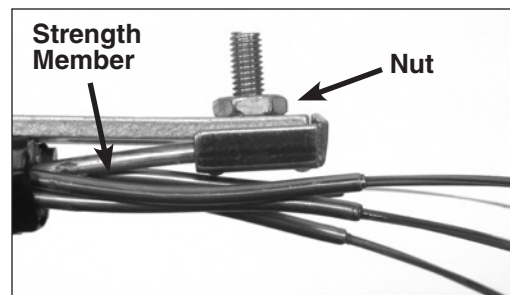



**Step #22** Align the cut ends of the outer strands with the end of the slot of the strength member bracket. (NOTE: When using the long strength member bracket, align the cut ends of the outer strands with the end of the slot nearest the leg of the bracket). Secure the cable to the bracket with a hose clamp.

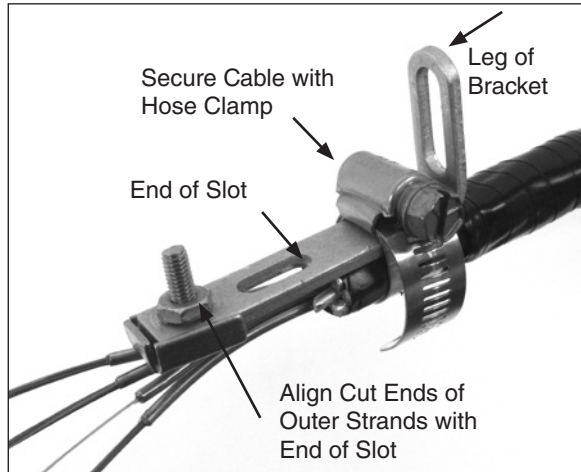

### Installation of the OPGW Cable into the End Plate

**Step #23** Slide the grommet back near the taped area.

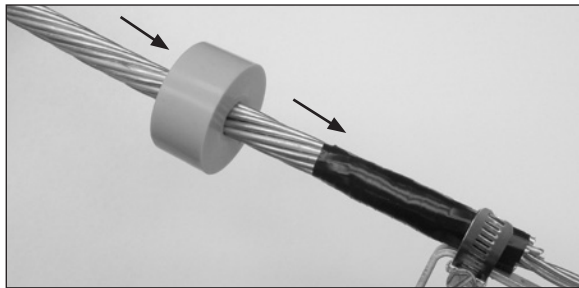

**Step #24** Lubricate the outer surface of the grommet.

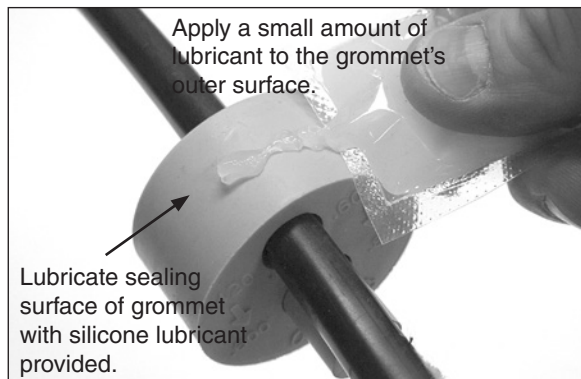

**Step #25** Position the grommet in the end plate slot.

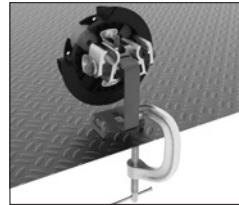
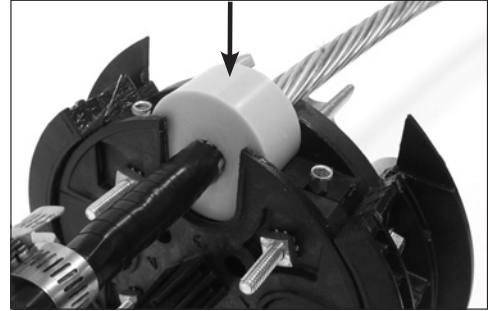

**PLP Tip:** The end plate can be stabilized during the remaining steps using the mounting adapter bracket and C-clamp. Secure the mounting adapter bracket to the CRB with the bolt and clamp the mounting adapter using a C-clamp to the work table.

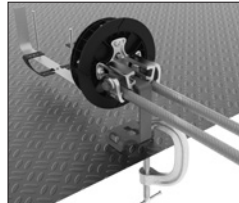

**Step #26** Position slot of the strength member bracket leg over the stud and pull the cable back.

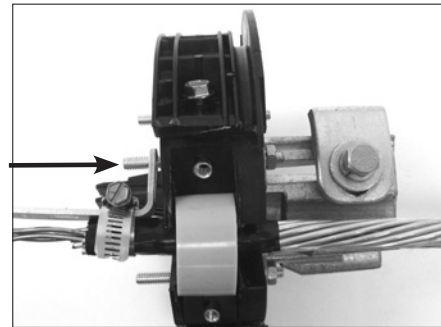

**Step #27** Install the strength member bracket on the stud. Install the lock washer and nut against the bracket, but do not tighten fully, so that the bracket can slide as the grommet is inserted.

Lock Washer and Nut

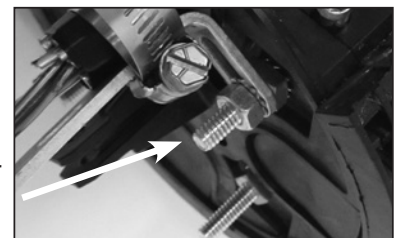

**Step #28** Secure the OPGW cable on the outside of the end plate by tightening the bolt of the CRB clamp. The bolt should be tightened to 25 ft.-lbs. The Aluminum CRB effectively provides electrical continuity between OPGW cables.

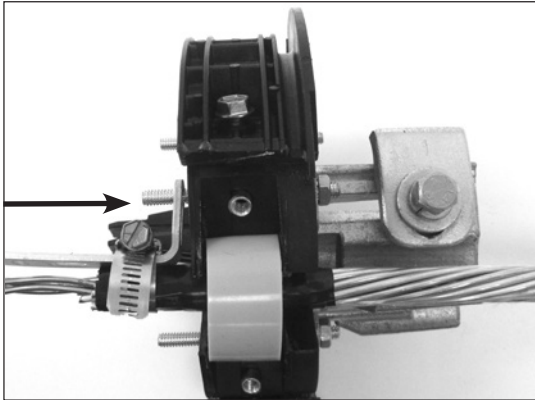

**NOTE:** If the upper cable ports are to be used, use the additional strength member brackets provided to restrain the cable. Secure one bracket to the top stud of the end plate as explained in Steps 27 & 28. Secure the remaining bracket to the same stud on the outside of the end plate. Use two hose clamps to secure the cable to the outside strength member bracket.

**Step #29** Install cable caps and secure with hex bolts.



**NOTE:** Tighten bolts by hand evenly until cable cap is fully seated (DO NOT USE POWER TOOLS TO TIGHTEN BOLTS).

When using a can wrench or nut driver, the installed torque is 35 to 40 in-lbs.

**NOTE: TIGHTEN ALL UNUSED CABLE CAPS.**

**IMPORTANT: TIGHTEN DOWN THE STRENGTH MEMBER BRACKET AFTER THE CAPS ARE TIGHTENED.**

**Step #30** End cap fully installed, shown below.

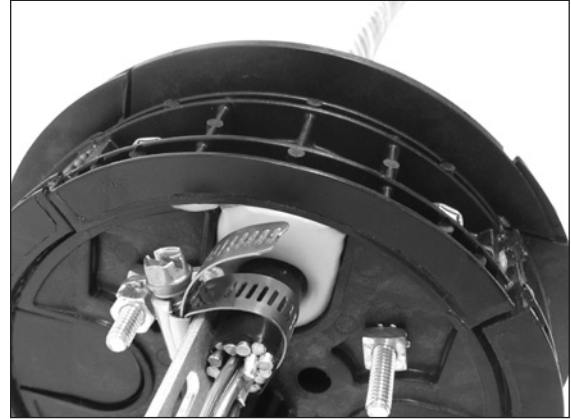

### Routing for OPGW Types 2 and 3

**Step #31** Route and store buffer tubes in storage brackets.

#### 6.5" x 17" Dome

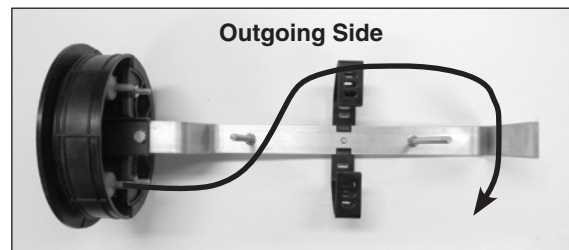
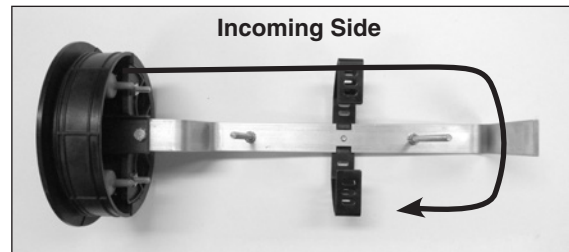

#### 6.5" x 22" Dome

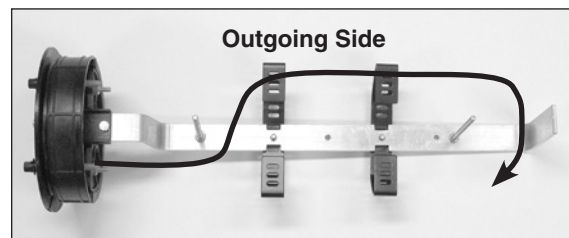
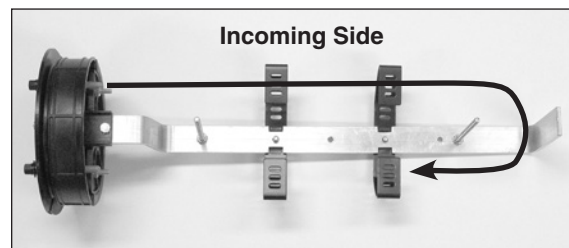

**Step #32** Route buffer tube(s) to splice tray(s). Wrap felt around the ends of each buffer tube and secure the buffer tube(s) to the splice tray(s) with tie wraps.

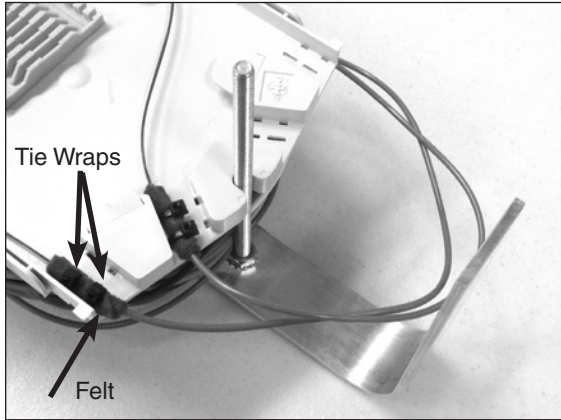

**Routing for OPGW Types 1 and 4**

**Step #33** If not completed already, remove the stainless steel buffer tubes up to the mark 1-1/2" (38 mm) away from the cut ends of the outer strands. Transition tubing is provided to protect and route the bare fiber from the stainless steel buffer tubes into the transition tray. Route the fiber from the lower entry ports to the transition tray and secure with tie wraps. Transition furcation kits may be used as well for additional protection as the bare fiber exits the stainless steel buffer tubes. See the chart at the beginning of this procedure and/or contact the cable supplier for further details. Refer to application procedure SP2963-4 for further information regarding how to apply transition furcation kits.

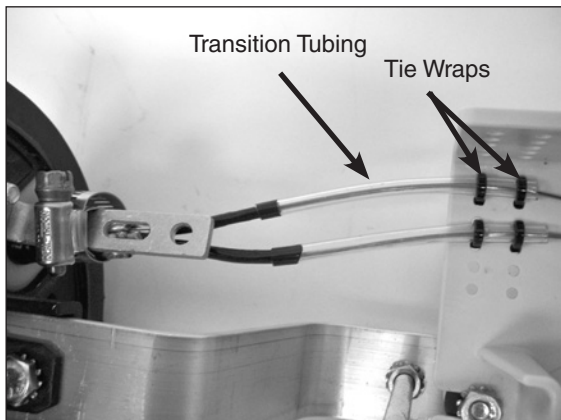

**Step #34** Route feeder fibers or ribbons within transition tray.

**6.5" x 17" Dome**

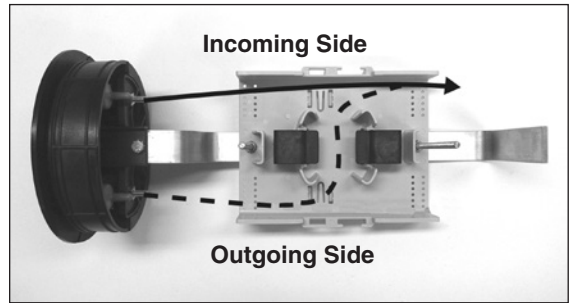

**6.5" x 22" Dome**

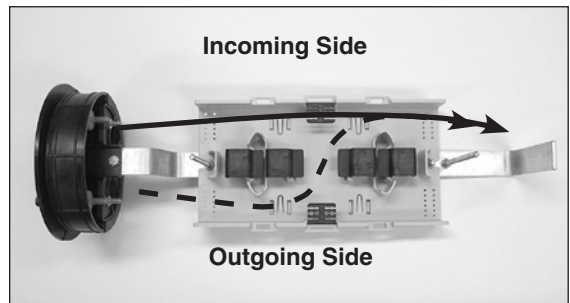

**Step #35** Route dark fibers under clips.

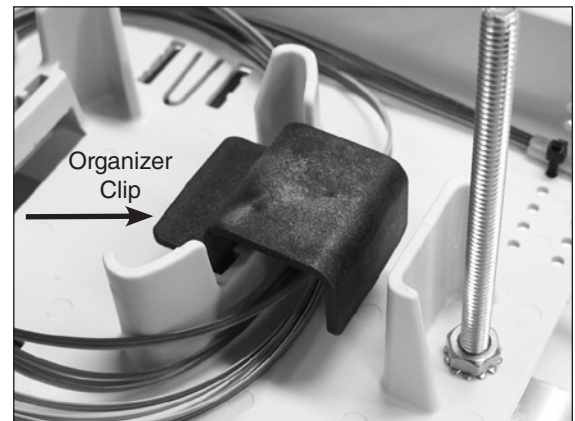

**Step #36** Insert fibers to be routed to splice tray(s) into transport tube(s) and secure tubes to transition tray with tie wraps.

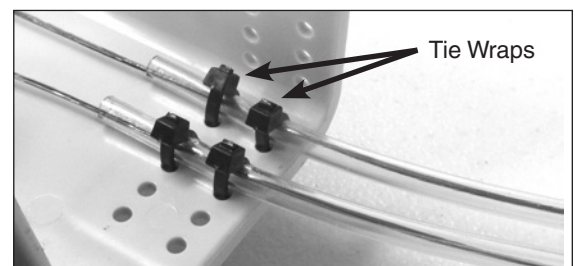

**Step #37** Install cover on transition tray.

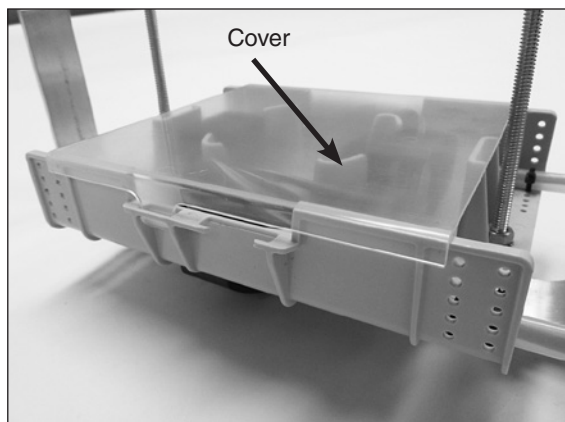

**Step #38** Route transport tube(s) to splice tray(s) and secure with tie wraps.

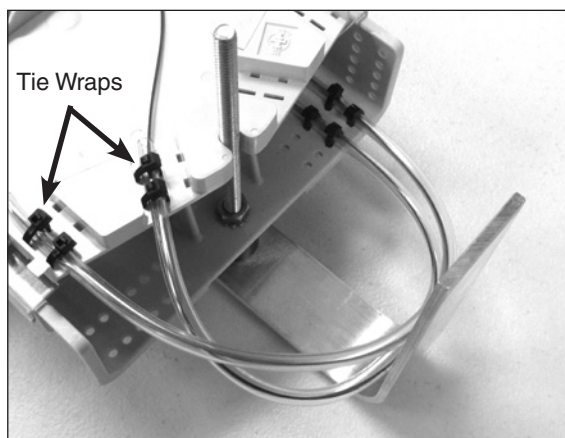

## Splice Tray Management

**Step #39** Routing for the 12 count splice tray for the 6.5" x 17" Dome are shown below.

**Incoming Fiber Routing**

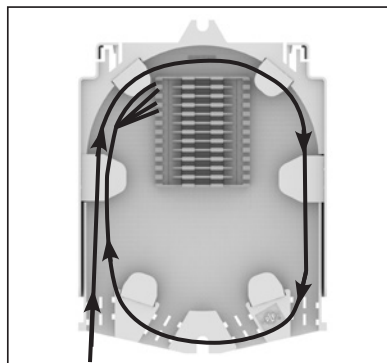

**Step #40** Routing for the 12 count splice tray for the 6.5" x 17" Dome is shown below.

**Outgoing Fiber Routing**

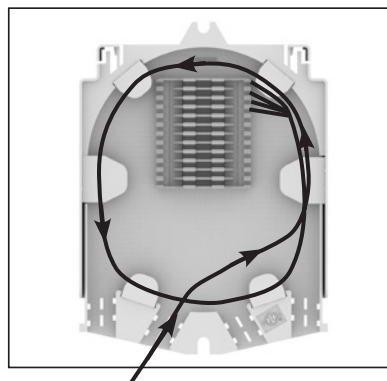

**Step #41** Route incoming fibers in splice tray.

**Splices 1-24**

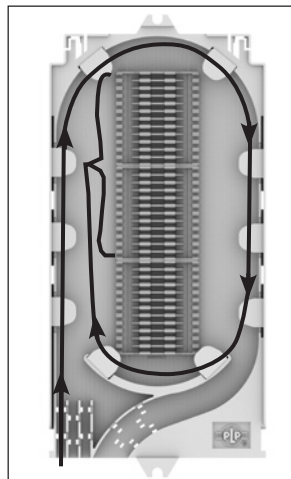

**Splices 25-36**

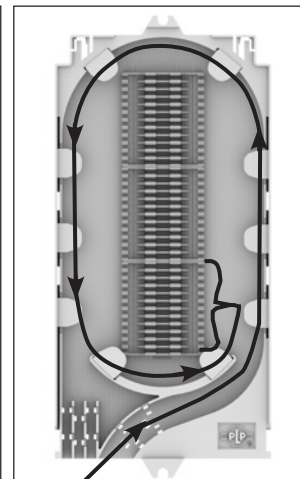

**Step #42** Route outgoing fibers in splice tray.

**Splices 1-24**

**Splices 25-36**

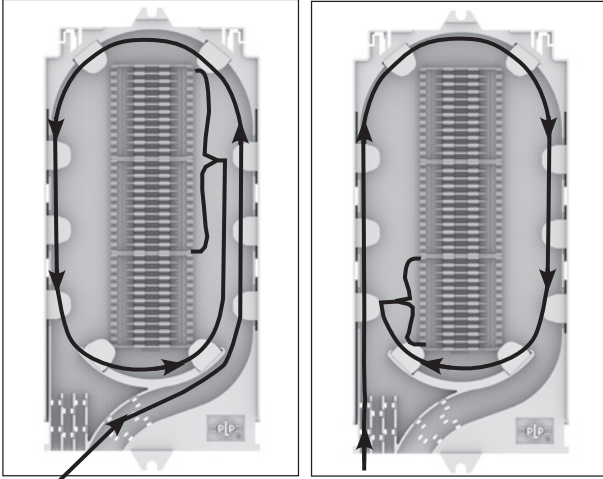

**Step #43** Splice incoming fibers to outgoing pigtail fibers per your accepted company practices.

**Step #44** Install cover on transition tray.

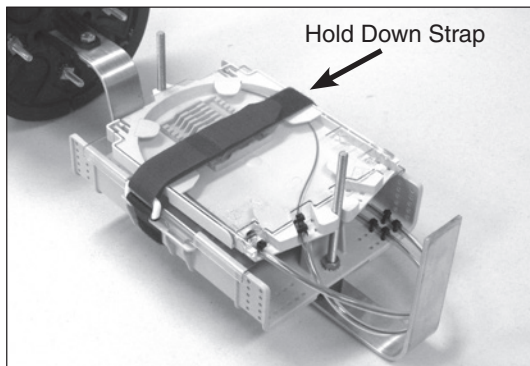

## Dome & Collar Installation

**Step #45** Lubricate all surfaces around gasket with silicone lubricant to assure easy assembly and closure re-entry.

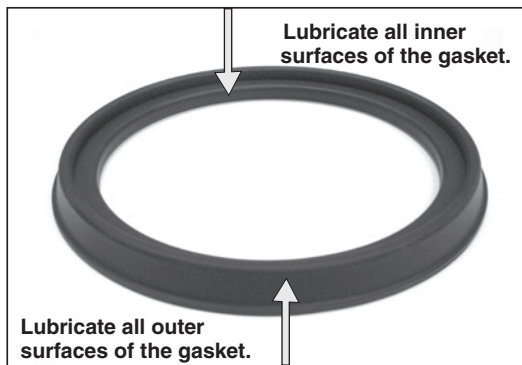

**Step #46** Slide end plate gasket onto end plate and press into groove.

**Make sure that gasket is fully seated in groove of end plate**

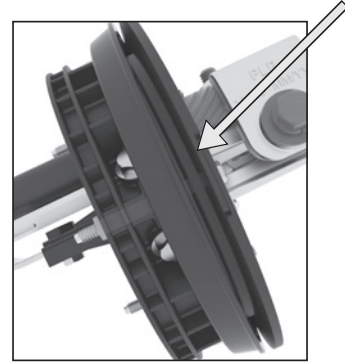

**Step #47** Work the gasket into the groove.

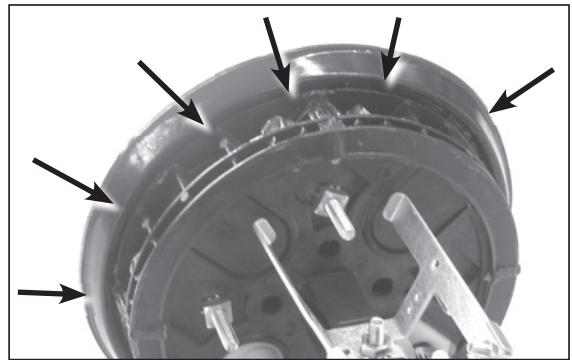

**Step #48** Re-tighten all cable cap bolts (step #29) to assure that the cable caps are fully seated. When using a can wrench or nut driver, the installed torque is 35 to 40 in-lbs.

**Step #49** Position the dome over the end plate.

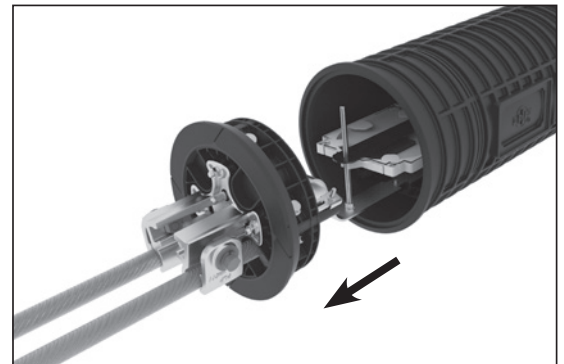

**Step #50** Position the collar flat on the work surface as shown below.

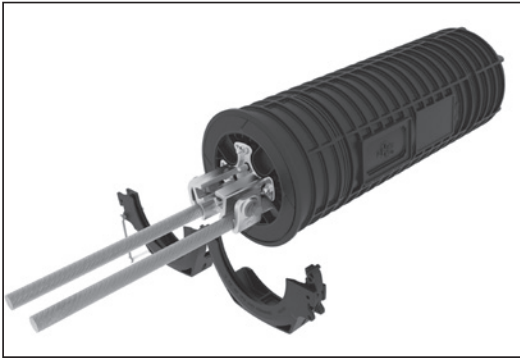

**Step #51** While holding the collar in place, compress a portion of the end plate into the dome and insert them in the groove of the collar near the latch, as shown below.

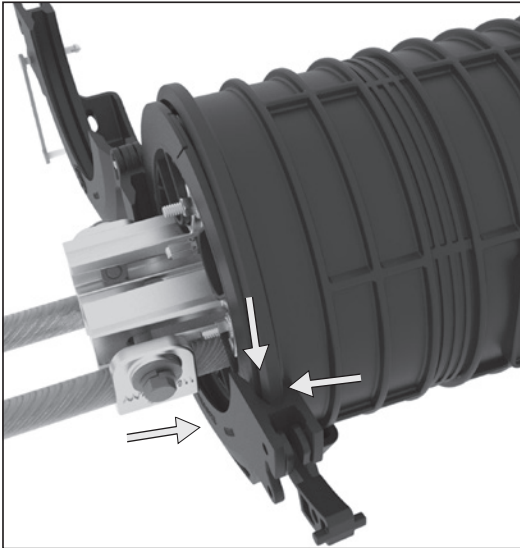

**Step #52** While holding the collar in place, push against the end of the dome and slightly lift and push the other half of the collar up and over the lip of the dome with your fingers to fully install the dome in the collar half.

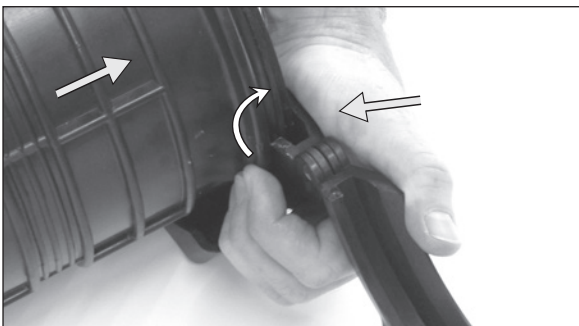

**Step #53** Check to make sure that the lip of the dome is captured within the collar half.

**Front Side**

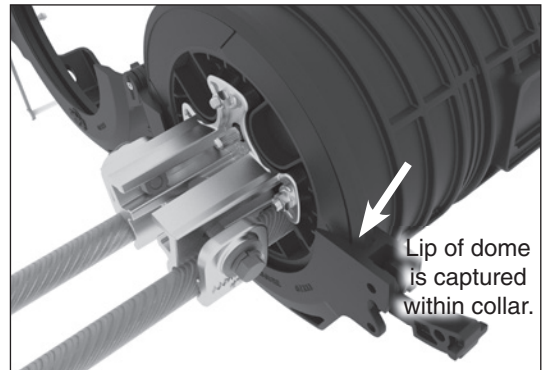

**Back Side**

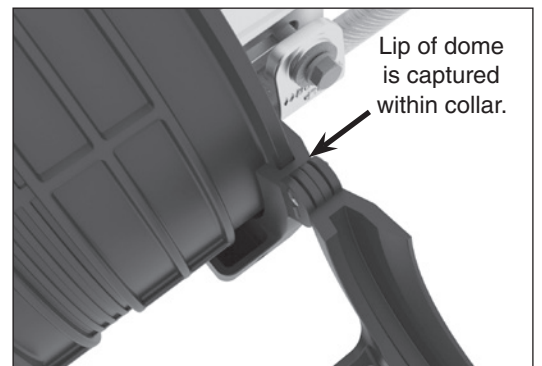

**Step #54** Install the other collar half onto the closure.

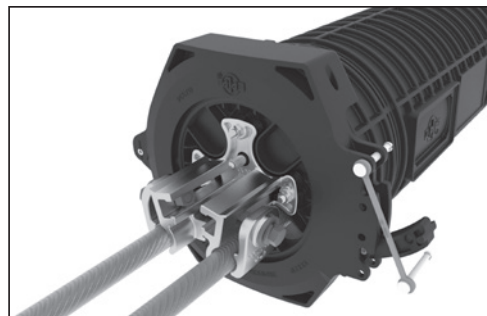

**Step #55** Secure the collar with the latch and pin.



## Flash Test Procedure

**Step #56** Remove cap from air valve of end plate.



**Step #58** Spray all sealing surfaces of the dome end-plate with soapy water to determine if there are any leaks.



**Step #57** Pressurize closure up to a max of 10 psi.



**Step #59** Release the pressure in the closure using the bump on the top of the air valve cap.

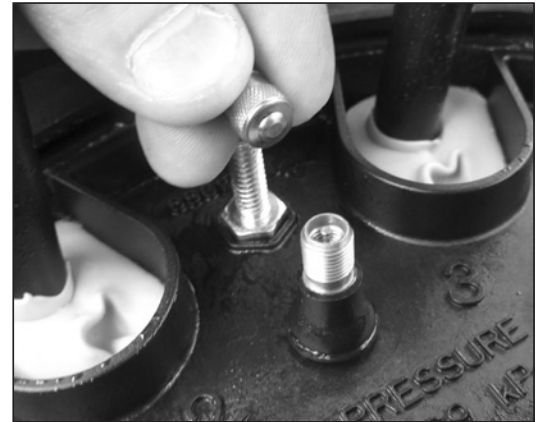

## Common End Plate Leaks During Flash Testing

Leak occurring at the corner of the cable port due to the cap of the cable port not being fully tightened.



Leak occurring at the corner of the cable port

To resolve, remove collar, remove End Plate/Organizer Assembly from the Dome, and tighten bolts on end cap where leak occurred. Reassemble and flash test to confirm that the leak has stopped.

Leak occurring at the cable entry of the grommet due to the cable not being within the stated cable diameter range of the grommet



Leak occurring at the cable entry of the grommet

To resolve, remove collar and remove End Plate/Organizer Assembly from the Dome. Remove end cap where leak occurred, remove grommet, remeasure cable with measure tape provided and select proper grommet. Reassemble the components and flash test the closure to confirm that the leak has stopped.



## Vertical Mounting

**Step #60 The COYOTE® Dome CRB slides onto the Mounting Adapter Bracket.**

The COYOTE Dome for OPGW slides onto the mounting adapter bracket. The mounting adapter bracket is secured with 3/8" bolt to the CRB. Use socket wrench with 9/16" socket.

The Mounting Adapter bracket can be mounted (a) directly to the structure via 5/8" bolt or 1-1/4" wide band (b) to the FIBERLIGN® Cable Storage 2 (c) to the COYOTE® Defender 2 or (d) to the Cable Storage & Defender combined – all shown below.

### Mounting Adapter Bracket and CRB

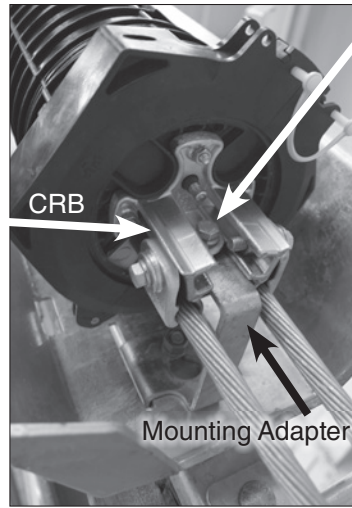

Secured to CRB with bolt



Fully Engaged

### OPTIONS for Mounting:

**a) Mounted directly to structure**



**b) Mounted to FIBERLIGN® Cable Storage 2**

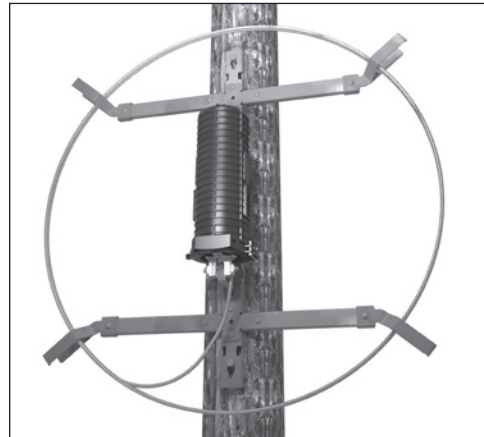

**c) Mounted to COYOTE® Defender 2**

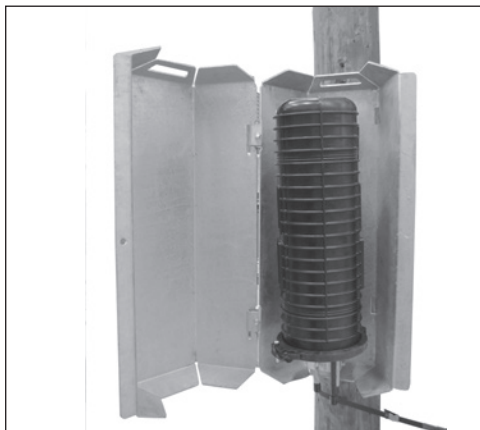

**d) Mounted to Cable Storage and COYOTE® Defender 2**







## SAFETY CONSIDERATIONS

This application procedure is not intended to supersede any company construction or safety standards. This procedure is offered only to illustrate safe application for the individual. **FAILURE TO FOLLOW THESE PROCEDURES MAY RESULT IN PERSONAL INJURY OR DEATH.**

**Do not modify this product under any circumstances.**

This product is intended for use by trained technicians only. **This product should not be used by anyone who is not familiar with, and not trained to use it.**

When working in the area of energized lines, extra care should be taken to prevent accidental electrical contact.

For proper performance and personal safety, be sure to select the proper size PREFORMED™ product before application.

PREFORMED products are precision devices. To insure proper performance, they should be stored in cartons under cover and handled carefully.



# PREFORMED LINE PRODUCTS

P.O. Box 91129, Cleveland, Ohio 44101 • 440.461.5200 • [www.preformed.com](http://www.preformed.com) • e-mail: [inquiries@preformed.com](mailto:inquiries@preformed.com)

SP3232-2