

NOMENCLATURE

End Plate Assembly Kit

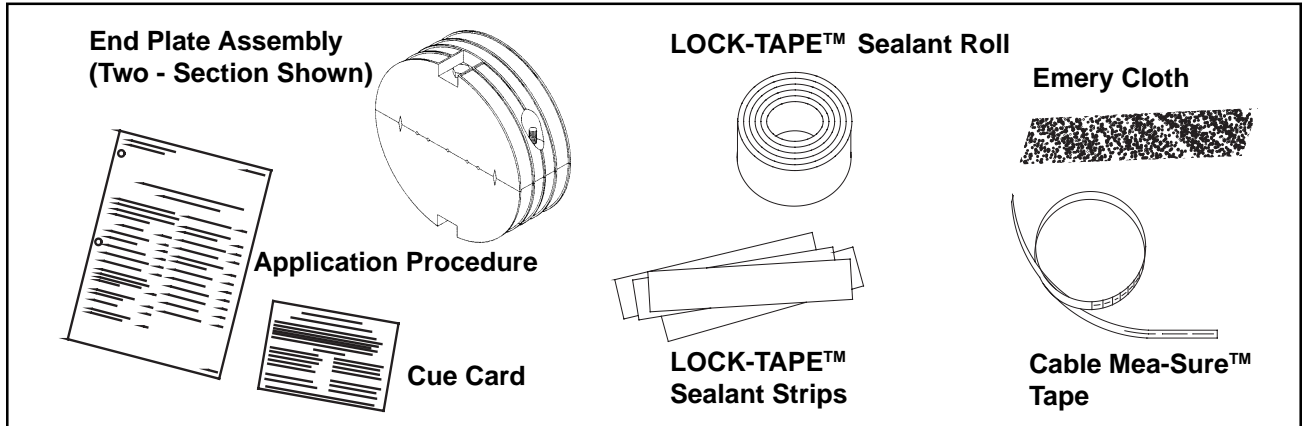

Dimensions & Capacities

Two-Section End Plates

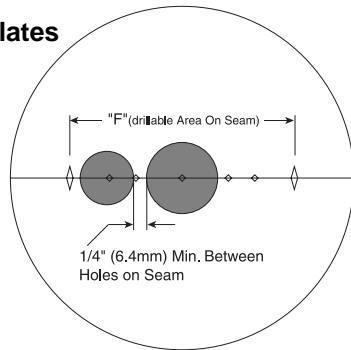

End Plate Size (mm)	"F" (mm)
4.0" (102)	2.2" (56)
6.5" (165)	4.1" (104)
8.0" (203)	5.6" (142)
9.5" (241)	7.1" (180)
12.5" (318)	9.3" (236)

End Plate Size (mm)	Maximum Combined Cable Diameters (mm)			
	1 Cable	2 Cables	3 Cables	4 Cables
4.0" (102)	2.2" (56)	1.95" (50)	1.70" (43)	1.45" (37)
6.5" (165)	4.1" (104)	3.85" (98)	3.60" (91)	3.35" (85)
8.0" (203)	5.6" (142)	5.35" (136)	5.10" (130)	4.85" (123)
9.5" (241)	7.1" (180)	6.85" (174)	6.60" (168)	6.35" (161)
12.5" (318)	9.3" (236)	9.05" (230)	8.80" (224)	8.55" (217)

Three-Section End Plates

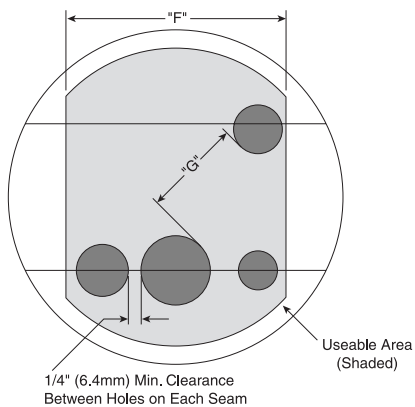

End Plate Size (mm)	"G" (mm)
6.5" (165)	3/8" (10)
8.0" & 9.5" (203 & 241)	1/2" (13)
12.5" (318)	3/4" (19)

1.

RACKING AND SECURING CABLE

Have at least 6" (152 mm) of straight and non-stressed cables entering the End Plates.

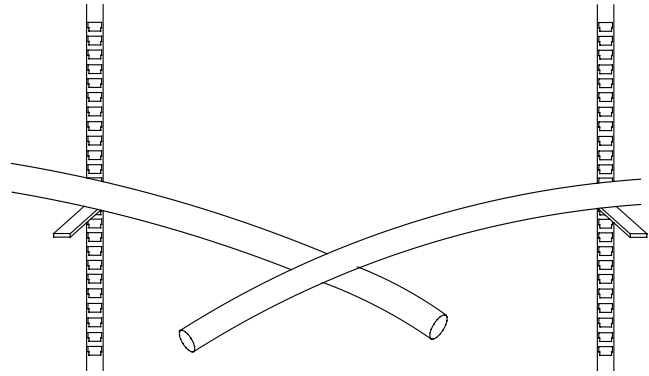

2.

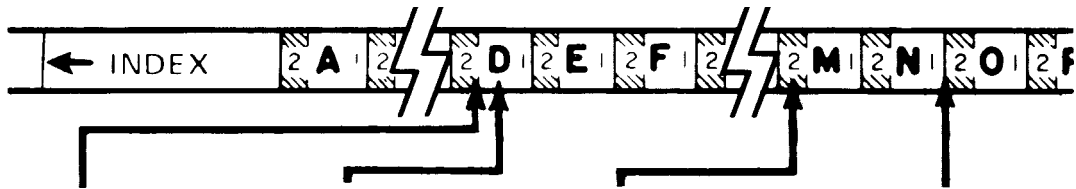

Use D blade and one half-lap of LOCK-TAPE™ Sealant.

The shaded area = two half laps.

Use D blade and one half-lap of LOCK-TAPE™ Sealant.

Use M blade and two half-laps of LOCK-TAPE™ Sealant.

The clear area = one half lap.

Use O blade and two half-laps of LOCK-TAPE™ Sealant.

Measure the cable to determine the proper blade sizes and number of LOCK-TAPE Sealant layers. If the index line falls on a line use the measurement immediately to the right of the line.

3.

Wrap the CABLE Mea-SURE™ Tape around the cable to determine the proper blade size and number of layers of LOCK-TAPE Sealant.

Note: For lead sheath cable, apply two half-lapped layers of LOCK-TAPE Sealant first, then measure with Cable Mea-SURE Tape to determine proper blade size and additional number of layers of LOCK-TAPE Sealant.

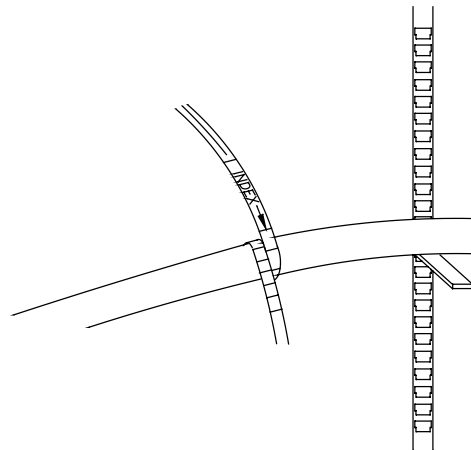

4.

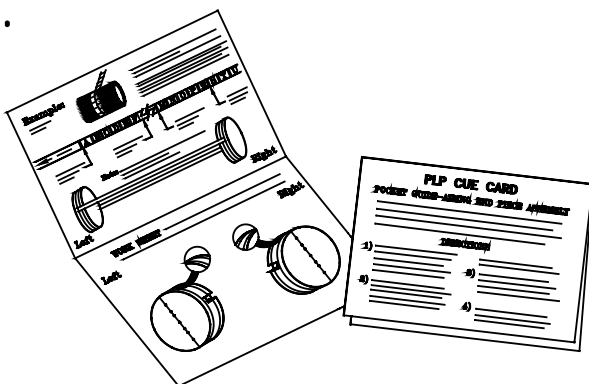

Use the PLP® CUE CARD as a worksheet to assure correct cutter blade size, proper hole cutting locations, and correct amount of LOCK-TAPE Sealant.

5.

POWER END PLATE CUTTER

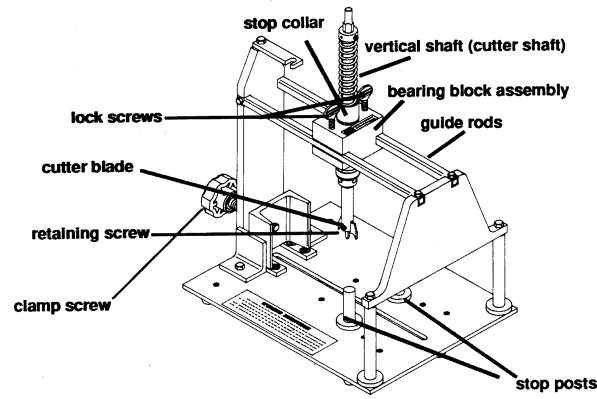

6.

Slide the blade into the adaptor and tighten the retaining screw.

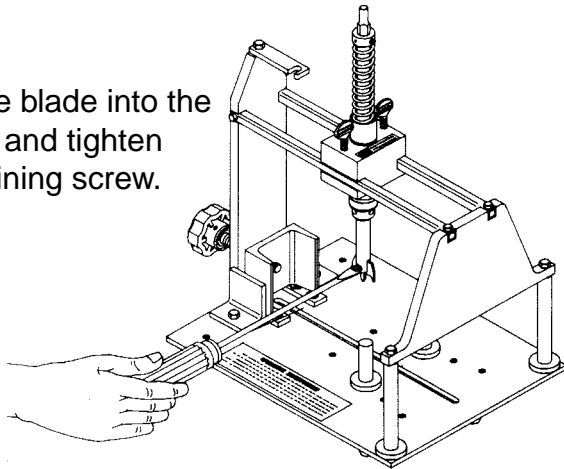

7.

Insert stop posts and hand tighten firmly.

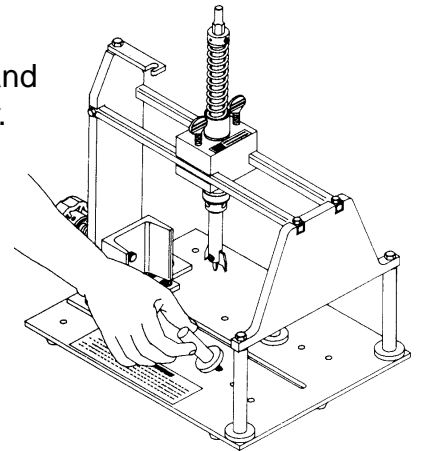

8.

Place End Plate in cutter on top of flanges of stop posts and clamp-jaw guides.

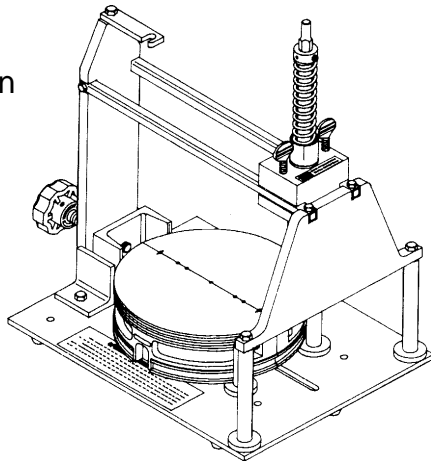

9.

Place End Plate with seam parallel to the guide rods and hand tighten clamp screw.

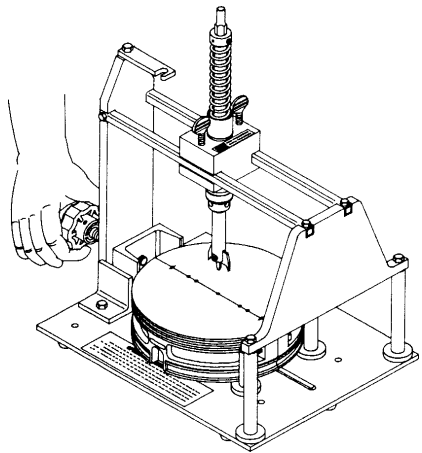

10.

Position the blade inside the designated marks.

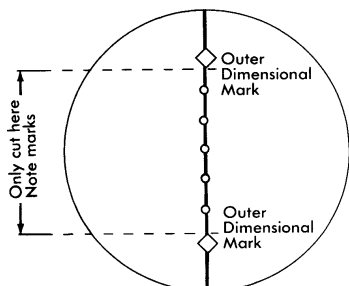

11.

Loosen lock screw in bearing block and lower shaft until center point of cutter blade is on desired position for center of hole.

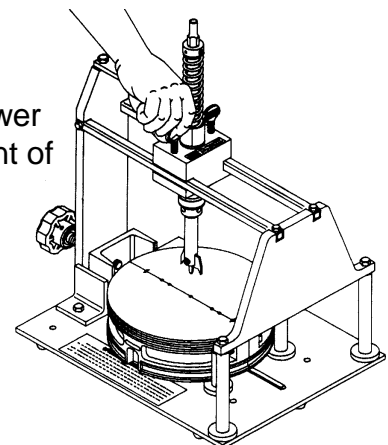

12.

Mount a 3/8" electric drill to the upper end of the cutter shaft. (PLP Catalog # 80851659). Cut through the black plastic until foam is just visible in ring.

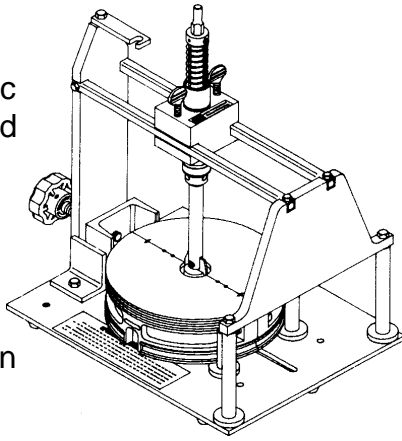

13.

Use a screwdriver to pop out the plastic disc (not necessary for A, B, C, and D blades). Continue drilling until stop collar on shaft bottoms on bearing block.

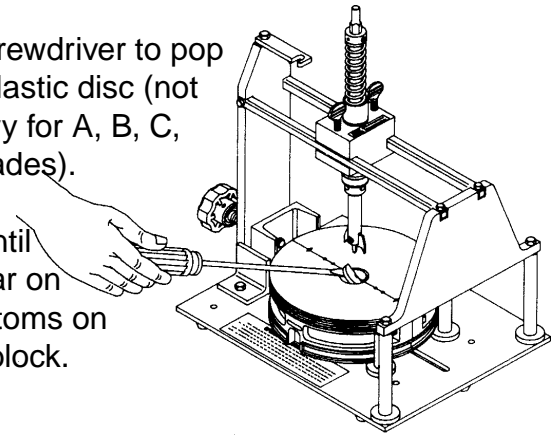

14.

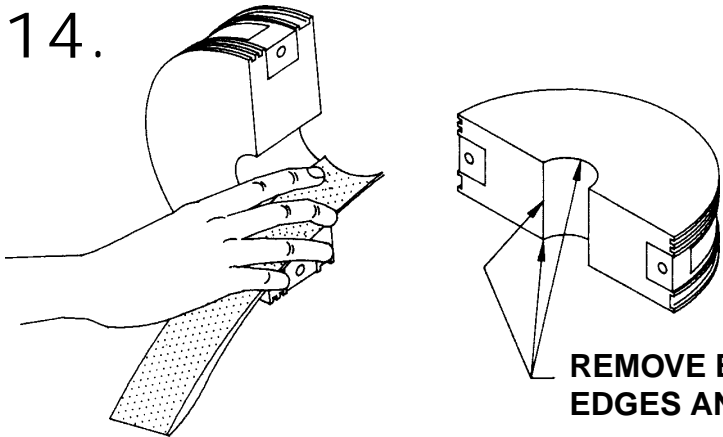

Scuff lightly using the emery cloth provided with the kit. Be careful not to remove too much material.

REMOVE BURRS LIGHTLY ON EDGES AND CORNERS ONLY

15.

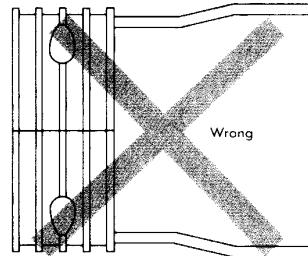
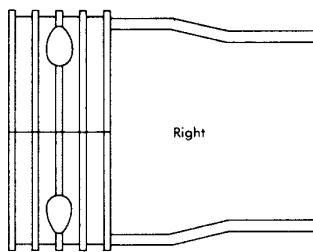

TORQUE BAR PLACEMENT

Apply Torque Bars to End Plates with threaded bolt holes. The offset in the bars should face the splice bundles as shown in above drawing.

16.

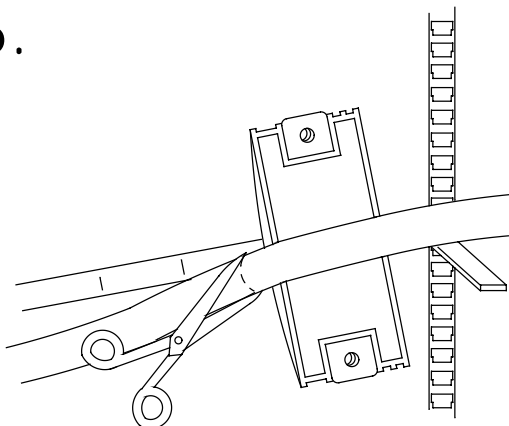

Use the Torque bar assembly to mark area to be cleaned and scuffed. Mark a 6" (152 mm) cable opening and coat scuffed area with C-Cement and allow it to dry to a tacky base.

17.

Half-lap LOCK-TAPE™ Sealant around cable.
Stretch while applying to reduce its width
to 1-1/8".

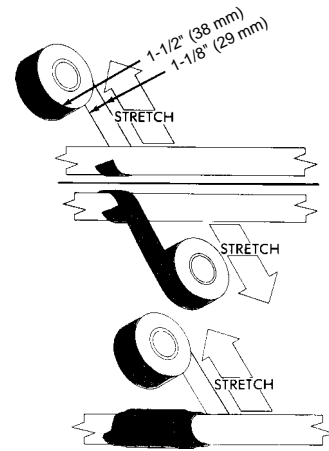

18.

LOCK-TAPE SEALANT APPLIED TO SHEATH

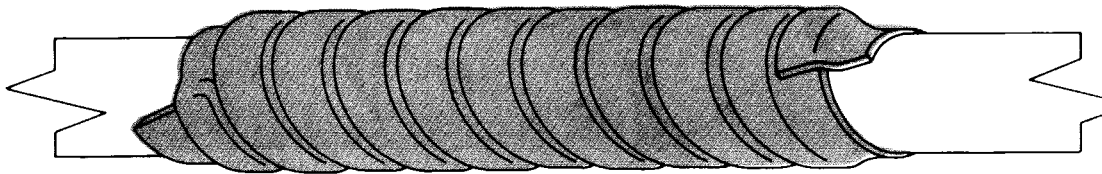

Be sure to keep the LOCK-TAPE™ Sealant wrap dry, free from grease and dirt.

19.

APPLY C-CEMENT TO END PLATE SURFACES

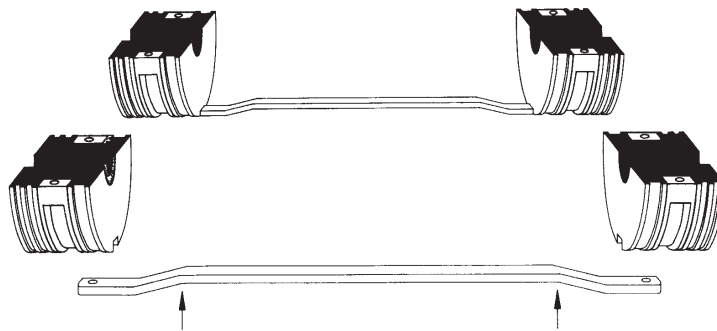

20.

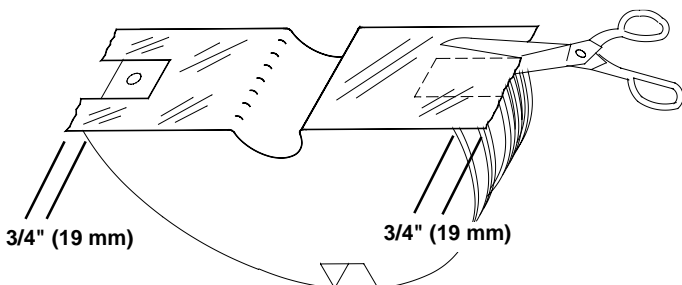

Apply LOCK-TAPE™ Sealant to End Plate halves without stretching. Leave 3/4" (19 mm) of sealant extending beyond End Plate on both sides. Square cut the tape way from bolt holes.

21.

Paint a strip of C-Cement over the LOCK-TAPE™ Sealant along the edge of the cable openings.

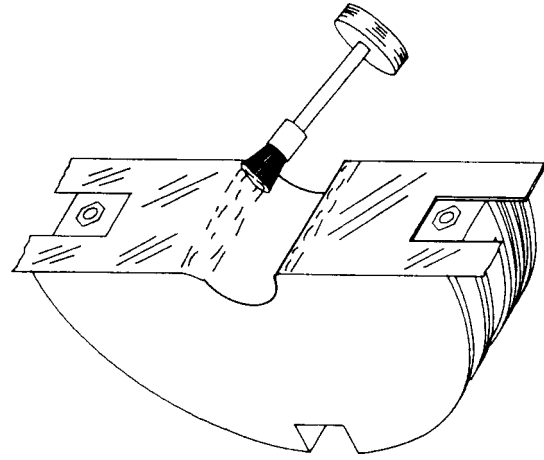

22.

COMPLETED PREPARATION OF END PLATE HALVES

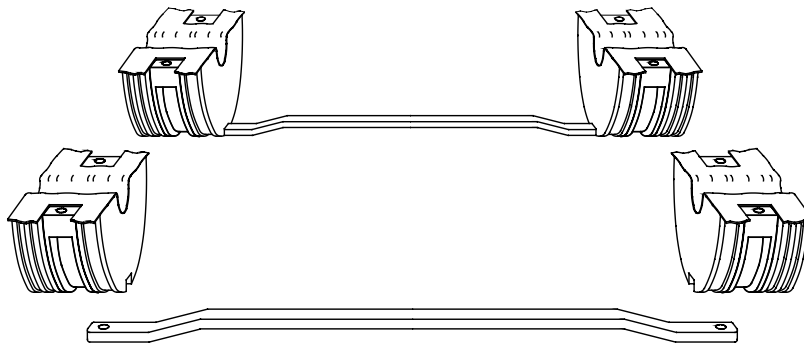

23.

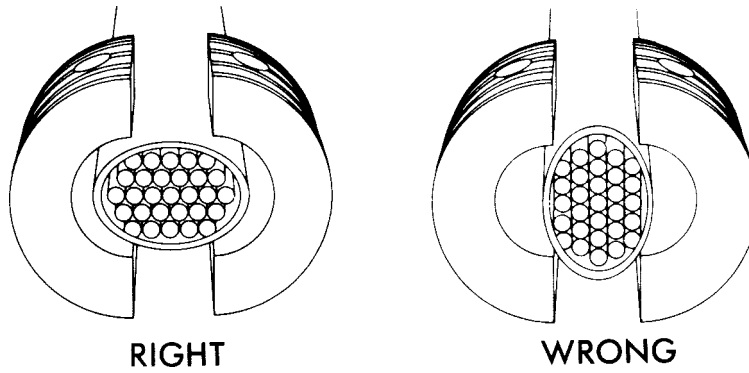

Using the cable shaper, compress cable to form a slight oval. Then, place End Plates as shown.

24.

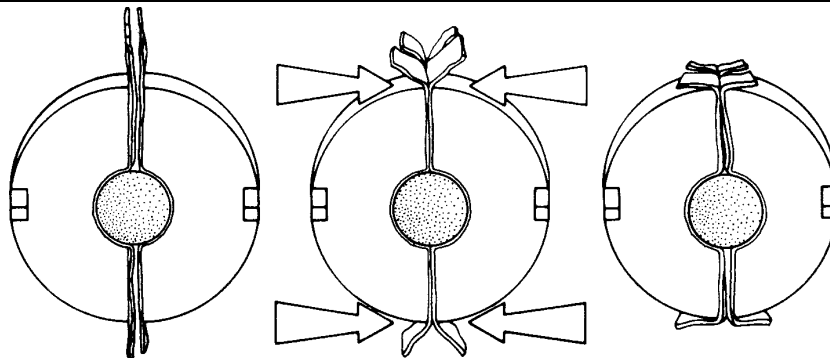

Using a ratchet wrench, draw the End Plate halves together evenly until the excess LOCK-TAPE™ Sealant separates and lays back.

25.

Trim the LOCK-TAPE™ Sealant flush with the End Plate. (Do not pull sealant)

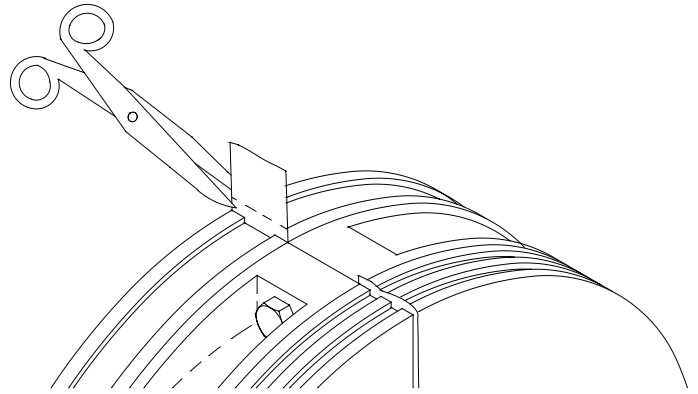

26.

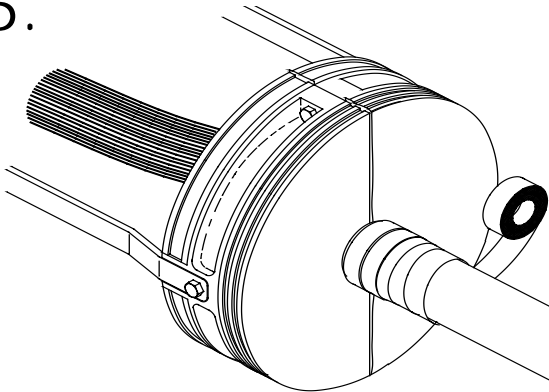

Apply two wraps of vinyl tape over exposed LOCK-TAPE™ Sealant on cables.

27.

For End Plates with a Bonding Insert, Extend Internal Bonding Braid through Shield Connector to End Plate Insert. Attach Braid to End Plate with Bonding Clip (provided).

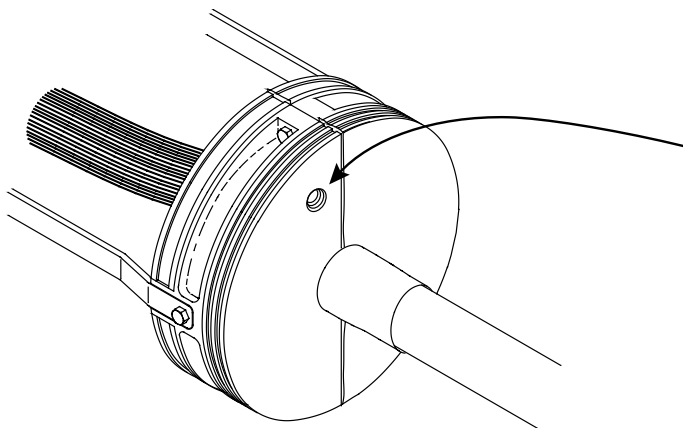
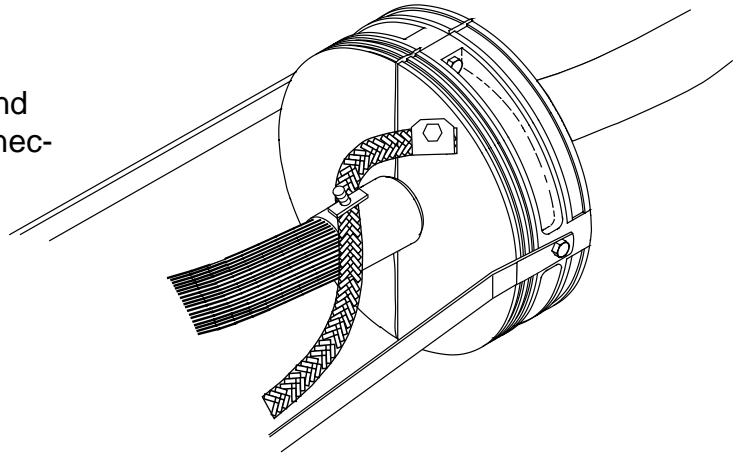

28.

For Underground & Buried Applications attach Bonding Braid or Bonding Strap to Insert on exterior of End Plate following standard company practices.

29.

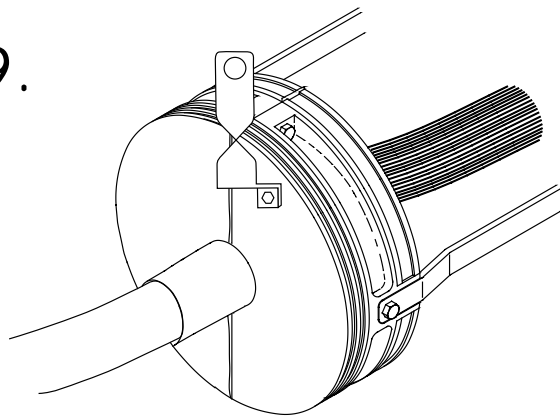

For Aerial Applications attach Aerial Hanger Bracket (available from PLP) to Insert on exterior of both End Plates, and attach to strand with messenger clamp (not provided).

30.

For End Plates with Air Valve Inserts, install an "F" Valve (not supplied) to flash test closure. Remove "F" Valve after flash test and install plug (provided).

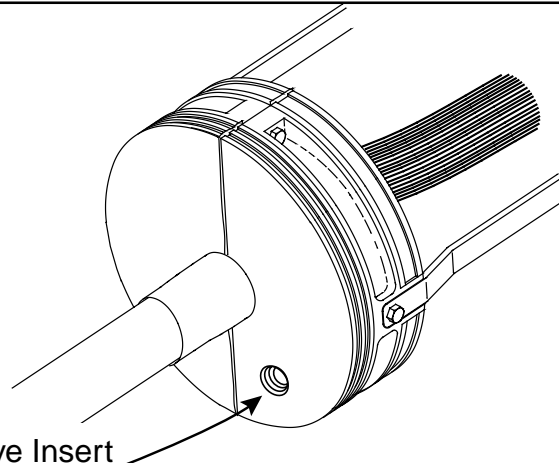

SAFETY CONSIDERATIONS

1. This Application Procedure is not intended to supersede any company construction or safety standards. This procedure is offered only to illustrate safe application for the individual. **CAUTION: FAILURE TO FOLLOW THESE PROCEDURES AND RESTRICTIONS MAY RESULT IN PERSONAL INJURY OR DEATH.**
2. This product is intended for the specified application. **CAUTION: DO NOT MODIFY THIS PRODUCT UNDER ANY CIRCUMSTANCES.**
3. This product is intended for use by trained craftspeople only. This product **SHOULD NOT BE USED** by anyone who is not familiar with and trained in the use of it.
4. When working in the area of energized lines with this product, **EXTRA CARE** should be taken to prevent accidental electrical contact.
5. For **PROPER PERFORMANCE AND PERSONAL SAFETY** be sure to select the proper size **PREFORMED™** products before application.
6. **PREFORMED™ PRODUCTS** are precision devices. To insure proper performance, they should be stored in cartons under cover and handled carefully.

PREFORMED LINE PRODUCTS 

P.O. Box 91129, Cleveland, Ohio 44101 • 440.461.5200 • www.preformed.com • e-mail: inquiries@preformed.com

SP2919-1