



# EARTH RODS

## AND ACCESSORIES

---

PLP - The Connection You Can Count On

---



## WE ARE YOUR TRUSTED MANUFACTURER

Preformed Line Products (Australia) has been manufacturing fittings for the power distribution market for more than 50 years. PLP manufactures fittings for bare and insulated overhead cabling for aluminium and copper systems for the power distribution sector and for rail networks.

PLP Australia manufactures products that cover the functions of termination, suspension, connection, protection along with a wide range of line hardware fittings and accessories. An extensive range of standard fittings are available off the shelf, however with PLP Australia's engineering expertise, skills and resources, PLP can effectively design, develop and produce fittings to overcome problems that face the customer in the field.

Although the majority of fittings in the upcoming distribution catalogue are to suit Australian Standard cable sizes, PLP Australia has additional products to suit United Kingdom, European and USA cable specifications.

If you have a particular requirement, please do not hesitate to contact PLP on (02) 8805 0000.

# TABLE OF CONTENT

<b>ABOUT US</b>	<b>4</b>
<b>ABOUT EARTH RODS</b>	<b>6</b>
Types of earth rods	6
Steel core earth rods	7
Earth rod length is more important than diameter	7
Earth Rod length is more important than quantity	8
Electrical resistance	8
<b>EARTHING BASICS</b>	<b>10</b>
What is earthing?	10
The purpose of earthing	11
Good earthing requires low soil resistivity	12
The Earth Path	13
Factors affecting soil resistivity	14
Essential site testing	16
<b>THE EARTHING RANGE</b>	<b>20</b>
Non-Extendable Bonded Earth Rod – Domestic	20
Copper Bonded Earth Rod – Domestic and Commercial	20
Copper Bonded Earth Rod – Pointed	21
Copper Bonded Earth Rod – Threaded	21
CBE & CBET Based on Imperial Diameter	22
Threaded Rod Couplers	22
Unthreaded Rod Couplers	22
Threaded Rod Driving Stud	22
Average Driving Head for CBE & STE	22
STE Series Stainless Steel Clad Rods	23
Stainless Steel Earth Rod Accessories	23
Driving Points	23
Connection Boxes	24
Earthing Enhancement Compounds	24
Earth Rod Clamps	25
Earth Mats and Installation Kits	28
Earthing Bond	30
Tower Bond	30
Copper Clad Steel Wire Conductor	31
Earth Stubs	32
CEC Connectors	33
Exothermic Welding Connection	35
Airport Earthing Terminal	37
Methods of installing Earth Rods	37

## ABOUT US **WHO WE ARE**

PLP (Preformed Line Products) is an Australian manufacturing company that has been supplying patented products to the electricity power utility, telecommunication, cable television and data network industries as well as specialised niche markets for more than 50 years.

PLP is a designer, manufacturer and supplier of high-quality cable anchoring and control hardware systems for supporting, protecting, terminating, and splicing transmission and distribution lines.

Experienced engineers provide technical support and inspection services comprising in-depth data analysis from unmanned aerial inspection vehicles for critical infrastructure.

Inventiveness, integrity, and foresight are the foundations of PLP, and the company continues to improve power utility networks by creating and building innovative new products for the industries it serves.

PLP has an extensive product range and the ability to provide solutions from experienced industry professionals to ensure the best outcome for your project.

PLP Australia has a dedicated team of on-site customer service staff and industry experienced external sales professionals to assist customers.



**PLP HAS BE PROUDLY  
MANUFACTURING IN  
AUSTRALIA FOR 60 YEARS.**

# ABOUT EARTH RODS

## Types of Earth Rods

At one time or another, all manner of conductor materials and shapes have been installed in the ground to provide an electrical earth. These materials range from cast iron plates, tubes, galvanised steel stakes, copper strip, metallic rod, wire and water pipe.



Taking into account conductivity, high resistance to atmospheric corrosion and soil attack, ease and economy of installation and overall reliability, the steel rod clad with either copper or stainless steel has proven its superiority over all others.

The copper bonded steel rod is simple to install and the connection to the earthing system is easily made. The installation is readily accessible for inspection and testing.

With the use of deep driving techniques, extendable earth rods have been developed to reach underlying strata of low permanent resistivity unaffected by seasonal drying.

## Steel Core Earth Rods

Electrically, a good earth rod should have a low intrinsic resistance and be of sufficient cross-section to carry high currents without damage when required.

Mechanically, its physical properties should exhibit strength, have a rigid core for easy driving and be of durable, corrosion resistant material.

PLP has extensive experience in the design and production of a variety of copper and stainless steel earth rods for domestic, industrial and substation applications.

The range includes the specially designed extendable earth rods which may be joined end to end to reach into the deeper levels of moist soil.

## Earth Rod Length is More Important Than Diameter

There is little advantage to be gained from increasing the diameter of the earth rod to increase the surface area in contact with the soil.

The usual practice is to select an earth rod with a diameter that will have enough strength to be driven into the soil without bending or splitting.

Large diameter rods may be more difficult to drive into the earth than smaller diameter rods.

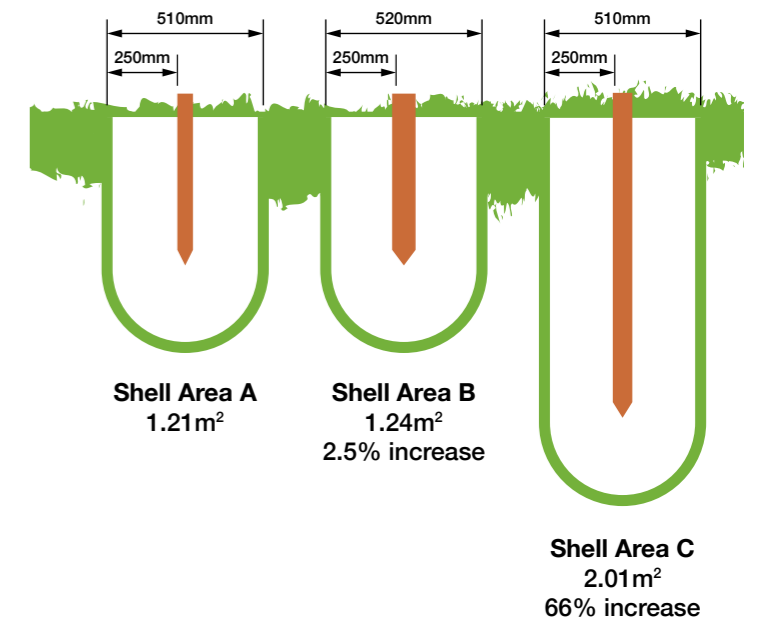

Image 7

## Earth Rod Length is More Important Than Quantity

The combined resistance of parallel rods is a complex function involving the number of rods, rod diameter, rod length, rod separation, the configuration of earth rods and soil resistivity.

In most cases, fewer rods coupled together for deep driving will achieve a lower resistance than the same number in parallel.

The earth rod spacing should not be less than the earth rod length to avoid overlap of resistance areas. This is because multiple earth rods, unless spaced well apart, do not follow the law of resistance in parallel as their earth conducting paths overlap.

The installation of multiple earth rods at sufficient distances apart takes up a large area, requires long cabling and many connections that all add up to higher costs in time, labour and equipment.

## Electrical Resistance

The depth to which an earth rod is driven into the earth has much more influence on its electrical resistance characteristics than its diameter.

This is because it is not the actual area of contact with the soil that counts, so much as the total resistance area of the sheath or shell surrounding the earth rod.

The resistance of an earthing installation by an earth rod is calculated according to the formula:

### Formula

$$R = \frac{\rho (\ln (8L) - 1)}{2\pi L d} \text{ Ohms}$$

where:

R = resistance of earth rod in Ohms

$\rho$  = soil resistivity in Ohm metres

L = length of earth rod in metres

d = diameter of earth rod in metres

The curve in Image 8 is based upon the above formula where the earth resistance using a 25mm diameter earth rod is plotted against its length for soil having a resistivity of 10 Ohm metres.

The curve shows a dramatic change when the length of the earth rod is increased.

Note: If the diameter of the earth rod is halved or doubled, the resistance is changed by 12.5%.

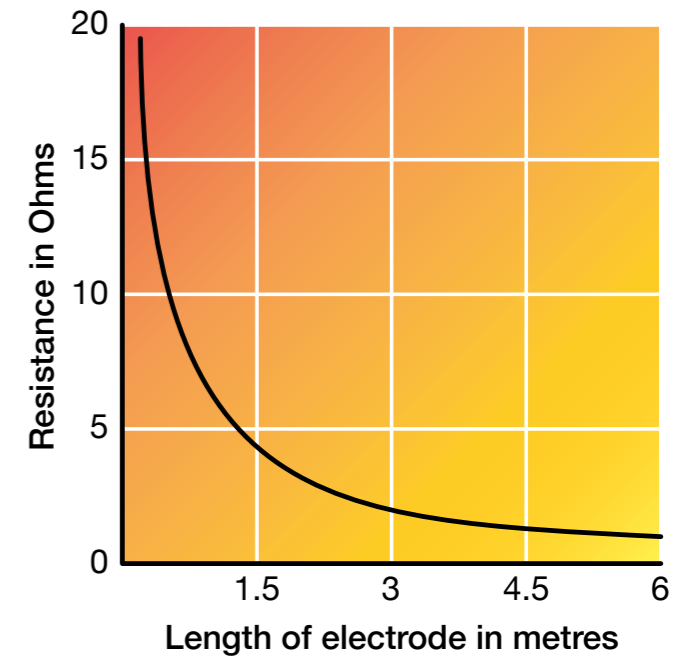
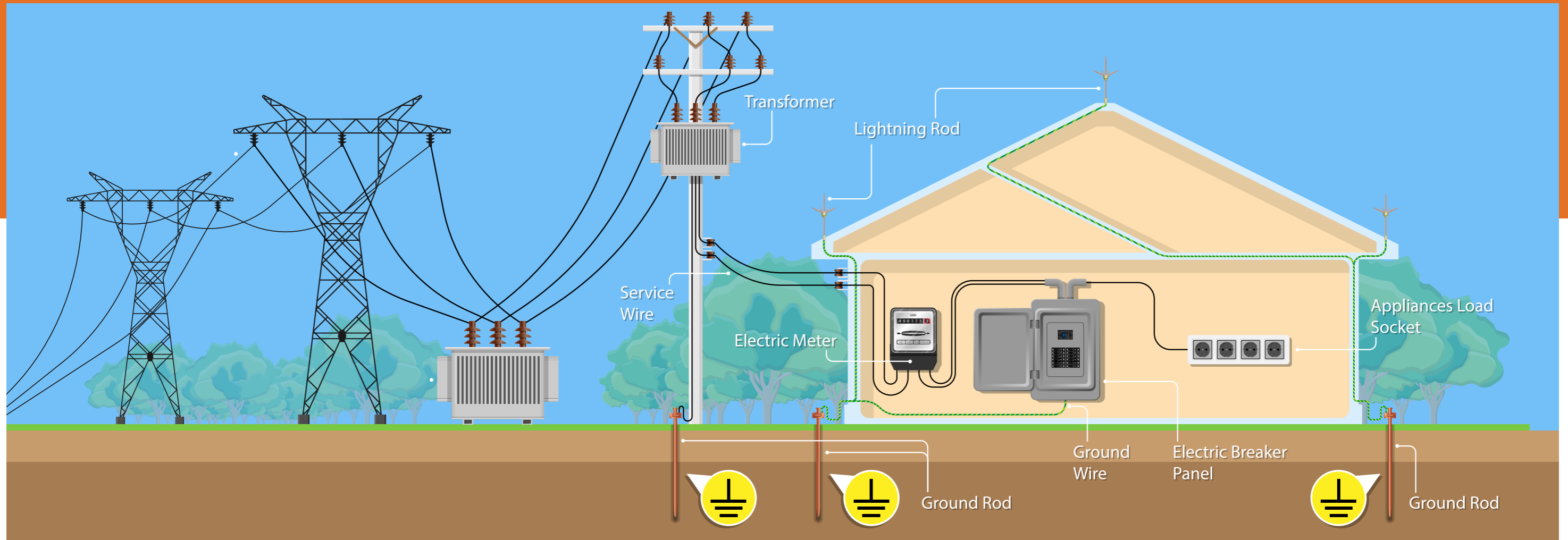

Image 8





## EARTHING BASICS

### What is Earthing?

Earthing, also known as grounding, refers to the process of creating a direct physical connection between electrical systems and the earth. This system of electrical connections ensures that any stray electrical currents are safely dissipated into the general mass of the earth.

The primary factor determining the effectiveness of an earthing system is the resistance of the earth electrode. The earth electrode is a conductor buried in the ground that provides a low-resistance path for electrical currents to flow into the earth. Lower resistance ensures that electrical faults and surges are efficiently conducted away from electrical systems, protecting both equipment and personnel from potential hazards.

### Purpose of Earthing

Earthing an electrical installation has two purposes:

1. To ensure that in the event of an electrical fault, excess current is safely directed into the ground, protecting individuals and animals from the risk of electric shock, and
2. To stabilize voltage levels within the electrical system, ensuring proper operation of electrical equipment and preventing malfunctions and damage.



## Good Earthing Requires Low Soil Resistivity

The resistance of the earth path is determined by:

---

The resistivity of the soil surrounding the earth rod,

---

Its contact resistance between the earth rod and the surrounding soil, and

---

The resistance of the earth rod and connecting conductors.

Soil resistivity is usually measured in Ohm metres, one Ohm metre being the resistivity the soil has when it has a resistance of one Ohm between the opposite faces of a cube of soil having one metre sides.

The other unit commonly used is the Ohm centimetre. To convert Ohm metres to Ohm centimetres, multiply by 100.

Soil resistivity varies greatly from one location to another. For example, soil around the banks of a river have a resistivity in the order of 1.5 Ohm metres. In the other extreme, dry sand in elevated areas can have values as high as 10,000 Ohm metres.



## The Earth Path

When an electrical current passes into the soil from a buried earth rod, it passes from a low resistance metal into an area of high resistance soil.

Images 1 and 2 below depict what happens when a current flows from an earth rod into the surrounding earth. The areas of resistance can be described as being that of a number of sheaths of ever increasing diameters.

The current path passes into the first sheath immediately adjacent to the earth rod and then into the second sheath which is of a larger cross-section with a greater area for current flow, and therefore, of lower resistance than the first sheath. And so on into a succession of sheaths or shells of ever increasing area, and because of this, of ever decreasing resistance.

Eventually at a distance of three or four metres, the area of current dissipation becomes so large, and the current density so small, the resistance at this point is negligible. Measurements show that 90% of the total resistance

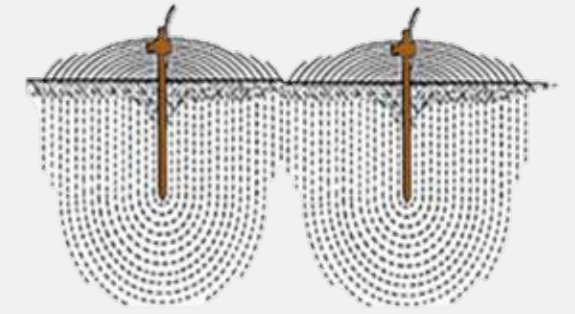

Image 1



Image 2

around an earth rod is within a radius of three metres.

However, it is this resistance at the interface where the current leaves the earth rod and flows into the main body of the earth that is important and explains why soil resistivity tests are very necessary in order to secure lowest overall resistance.

## Factors Affecting Soil Resistivity

### Types of Soil

Soil composition can be clay, gravel, loam, rock, sand, shale, silt or stones. In many locations soil can be quite homogeneous, while other locations may be mixtures of these soil types in varying proportions. Very often soil composition is in layers or strata, and it is the resistance of the varying strata, especially at sub-soil level and lower where the moisture content is not subject to drying out, that is important in securing a good electrical earth. Refer Table 1 (page 6) for typical soil resistivity values.



### Seasonal Conditions

The effects of heat, moisture, drought and frost can introduce wide variations in “normal” soil resistivity. Soil resistivity usually decreases with depth, and an increase of only a few percent of moisture content in a normally dry soil will markedly decrease soil resistivity. Conversely, soil temperatures below freezing greatly increase soil resistivity, requiring earth rods to be driven to even greater depths. See Table 2 for variations of soil resistivity with moisture content, and Table 3 for variations of soil resistivity with temperature.



### Climate

The climate plays a significant role in determining soil resistivity. Arid climates, characterized by low humidity and minimal rainfall, typically result in higher soil resistivity. In contrast, regions with substantial rainfall and higher humidity levels tend to have lower soil resistivity due to increased moisture content in the soil.

### Other Factors

In addition to climate, several other soil properties contribute to soil resistivity: Soils rich in certain minerals and salts can conduct electricity more efficiently, thereby lowering resistivity.

The presence of ions in the soil enhances its conductivity. Ion-rich soils usually have lower resistivity.

Uniformly sized and well-distributed soil grains help in maintaining consistent moisture levels, which is conducive to lower resistivity.

The ability of soil to retain moisture is a critical factor. Soils that retain moisture well provide better contact with the earth rod, resulting in lower resistivity.

These factors collectively contribute to the substantial variation in soil resistivity observed across different soil types and moisture contents. By considering these variables, one can better design and implement earthing systems that meet safety and performance standards.

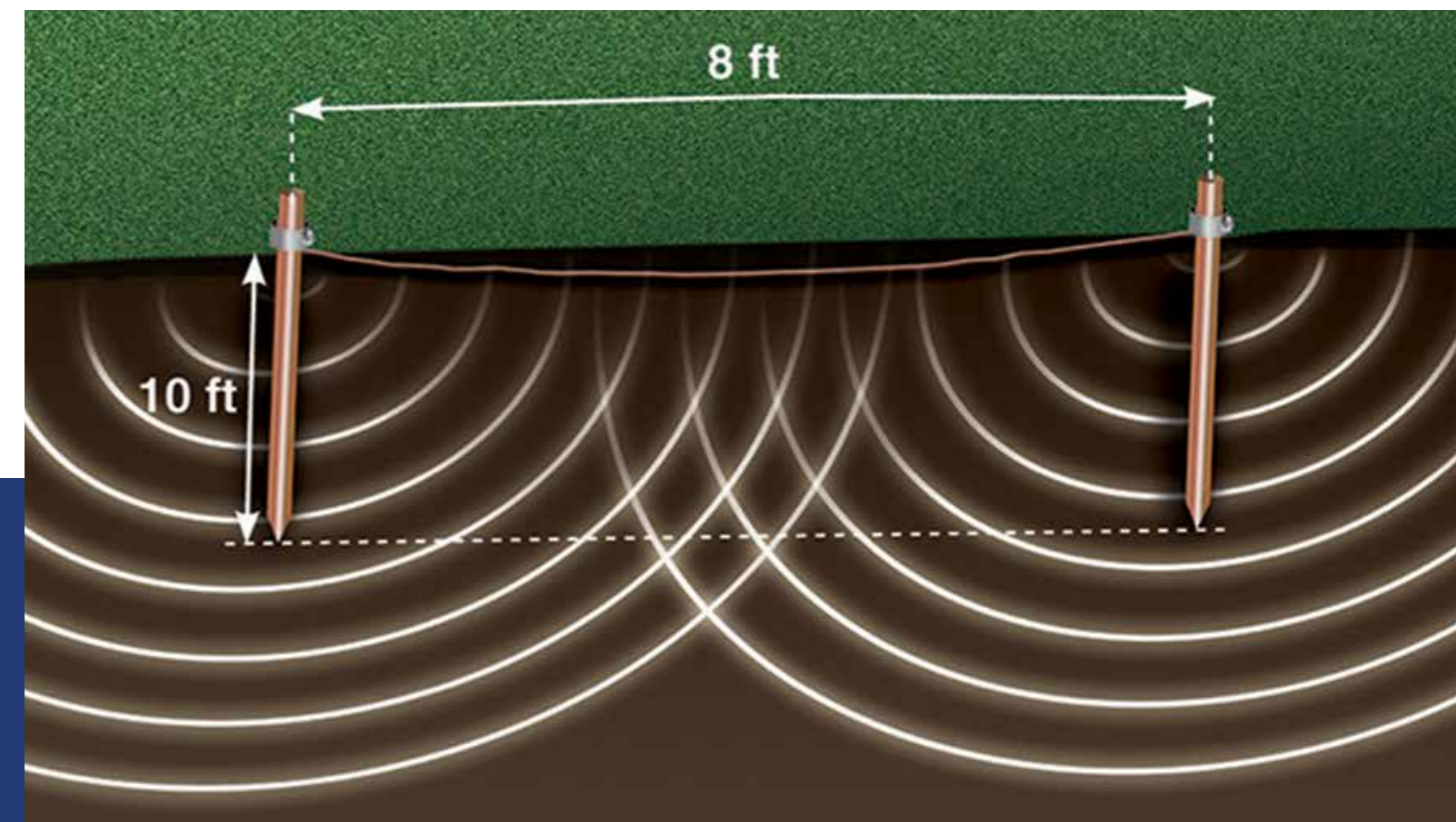

## Essential Site Testing

Ensuring the effectiveness of an earthing installation is critical for both safety and compliance with regulations. Each earthing system is unique, and the only reliable way to verify that an installation meets code requirements is through precise on-site resistance measurements.

A range of test instruments is available for this purpose. These instruments

generally fall into two categories: three-terminal and four-terminal test instruments. Three-terminal testers are typically used for basic assessments, while four-terminal testers provide more accurate readings by eliminating the effects of contact resistance. Proper selection and usage of these instruments are crucial to obtaining accurate and meaningful results.

### Measuring Resistance

Image 3 illustrates the test setup for measuring the resistance in Ohms between the installed earth rod and the general mass of earth. Refer to the instrument manufacturer's manual on how to carry out the test. As a general rule, the distance between the earth rod under test and the current probe "C" is not less than 15 metres.

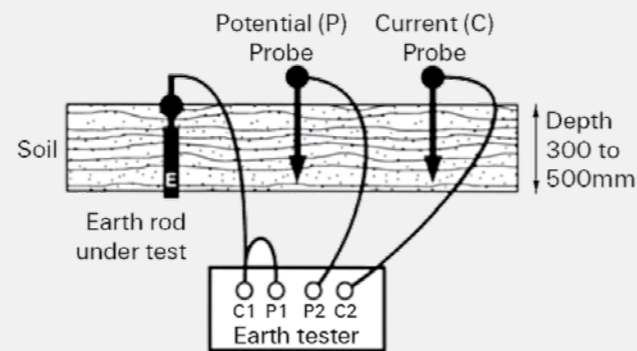

Image 3

### Measuring Soil Relativity

Image 4 illustrates the simple test setup for measuring soil resistivity. The test results give a resistivity profile of the earth beneath the surface.

A four-terminal instrument is required for soil resistivity. The probes are installed in a straight line with an equal

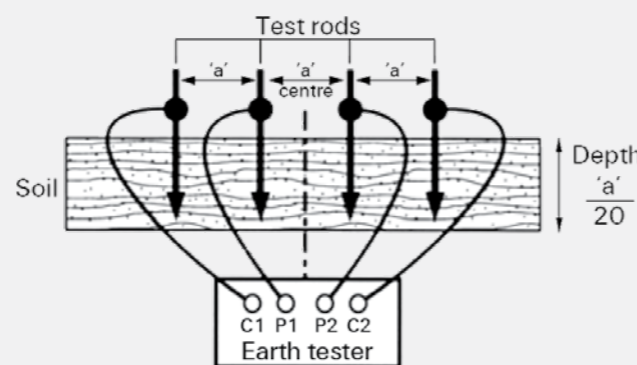

Image 4

spacing and inserted to a depth of no more than 20 metres. For example, for a spacing of two metres the depth must be less than 100mm.

Keeping the centre position the same, resistance measurements are taken at

### Measuring Resistance

The soil resistivity can be obtained from the following formula:

The resistivity at probe spacing 'a' metres and the average resistivity to a depth of 'a' metres is a good approximation for most circumstances.

Using the above formula, the soil resistivity versus depth profile can be drawn from Images 5 and 6.

The profile can be used to identify where low resistivity soil occurs so that appropriate installation techniques can be used. As the soil resistivity decreases with depth, deep driving earth rods are recommended.

If the soil resistivity increases with depth, earth rods should be installed in parallel to obtain a lower resistance reading. Best results are achieved when the spacing of the parallel earth rods is greater than their depth.

increasing spacings. For example a = 2m, 3m, 4m, etc. Always ensure that the spacing between individual test probes are identical.

### Formula

$$R = 2\pi a R \text{ (Ohm metres)}$$

Where:

$\rho$  = apparent soil resistivity

a = spacing of probes in metres

R = resistance value in Ohms (as indicated on the tester)

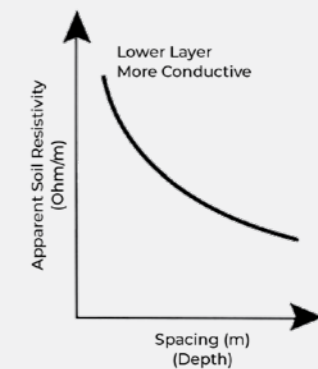

Image 5

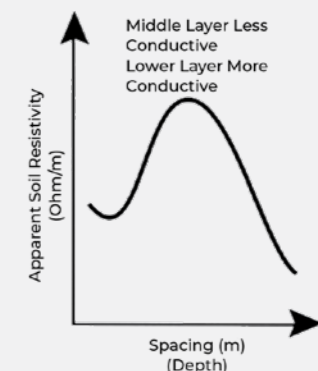

Image 6

Table 1 – Resistivity values for several types of soils and water

Type of Soil or Water	Typical Resistivity $\Omega\text{m}$	Usual Limit $\Omega\text{m}$
Sea Water	2	0.1 to 10
Clay	40	8 to 70
Ground well and spring water	50	10 to 150
Clay and sand mixtures	100	4 to 300
Shale, slates, sandstone	120	10 to 1,000
Peat, loam and mud	150	5 to 250
Lake and brook water	250	100 to 400
Sand	2,000	200 to 3,000
Morane gravel	3,000	40 to 10,000
Ridge gravel	15,000	3,000 to 30,000
Solid granite	25,000	10,000 to 50,000
Ice	100,000	10,000 to 100,000

Table 2 – Variations of soil resistivity with moisture content

Moisture Content % of Weight	Typical Value of Resistivity $\Omega\text{m}$	
	Clay Mixed with Sand	Sand
0	10,000,000	-
2.5	1500	3,000,000
5	430	50,000
10	185	2,100
15	105	630
20	63	290
30	42	-

Table 3 – Variations of resistivity with temperature

Temperature with a mix of sand and clay and a moisture content of about 15% by weight.

Temperature $^{\circ}\text{C}$	Typical Value of Resistivity $\Omega\text{m}$
20°	2
10°	40
0° (water)	50
0° (ice)	100
-5°	120
-15°	150



# THE EARTHING RANGE

## Non-Extendable Bonded Earth Rod - Domestic

At one time or another, all manner of conductor materials and shapes have been installed in the ground to provide an electrical earth. These materials range from cast iron plates, tubes, galvanised steel stakes, copper strip, metallic rod, wire and water pipe.

Part Number	Description	Pack Quantity
CBE-127-1400-DOM	Domestic earth rod assembly (includes earthing clips and tags)	10

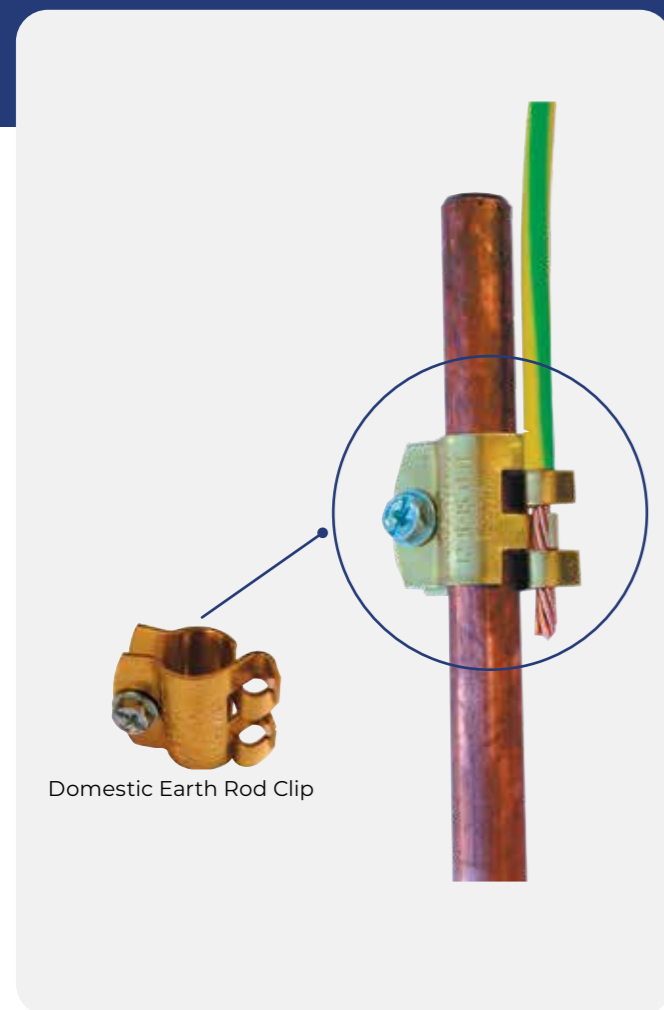

## Copper Bonded Earth Rod – Domestic and Commercial

The CBE Copper Bonded Earth Rod provides an effective solution for domestic as well as commercial earthing applications.

Manufactured from low carbon high tensile steel with pure copper plating at >250 microns, molecularly bonded onto the steel rod. All Copper Bonded Earth Rods supplied by PLP are tested in accordance with IEC62561-2 : 2018.

## Copper Bonded Earth Rod – Pointed



Rod Diameter mm	Part Number	Length mm
12.7	CBE-127-1400	1400
12.7	CBE-127-1800	1800
14.2	CBE-142-1500	1500
14.2	CBE-142-1800	1800
14.2	CBE-142-2400	2400
19	CBE-190-1800	1800
19	CBE-190-2400	2400
19	CBE-190-3000	3000

## Copper Bonded Earth Rod – Threaded



Rod Diameter mm	Part Number	Length mm
13	CBET-130-1400	1400
13	CBET-130-1800	1800
15	CBET-150-1800	1800
15	CBET-150-2400	2400
15	CBET-150-3000	3000
19	CBET-190-1400	1400
19	CBET-190-1800	1800
19	CBET-190-3000	3000

## CBE & CBET Based on Imperial Diameter

Rod Diameter mm	Part Number
12.7	CBET-130-xxxx
14.2	CBET-150-xxxx
17.2	CBET-190-xxxx
17.2	CBE-190-xxxx

### Threaded Rod Couplers



Rod Diameter mm	Part Number
13	CBET-130-COUPLER
15	CBET-150-COUPLER
19	CBET-190-COUPLER

### Threaded Rod Driving Stud

Rod Diameter mm	Part Number
13	DS-13
15	DS-15
19	DS-19

### Unthreaded Rod Couplers



Rod Diameter mm	Part Number
12.7	CBE-127-COUPLER
14.2	CBE-142-COUPLER
19	CBE-190-COUPLER

### Average Driving Head for CBE & STE

Rod Diameter mm	Part Number
12.7 / 13mm	DHT15
14.2 / 15mm	DHT15
17.2 / 19mm	DHT19

## STE Series Stainless Steel G304 Rods



Rod Length	13mm Diameter	Pack/Bulk Quantity
1200	STE1312	10/500
1400	STE1314	10/500
1800	STE1318	5/500
2400	STE1324	5/500
3000	STE1330	1/50

## Stainless Steel Earth Rod Accessories

<b>Coupling</b>	SCT13	10/100
<b>Point</b>	DPT12	50/200
<b>Star Point</b>	SDP12T	10/100

### Driving Points

Part Number	Description
DPT12	Average Driving Point 13mm
DPT15	Average Driving Point 19mm
SDP12T	Hard Driving Point 13mm
SDP15T	Hard Driving Point 19mm

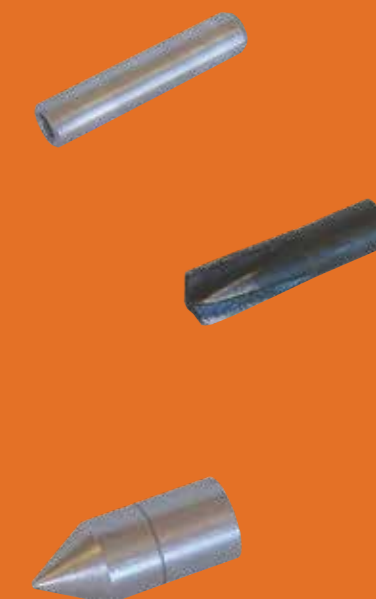

## Connection Boxes

These enclosures provide a tidy means of protecting the connection of the main earth conductor to the earth rod. Manufactured from high strength aluminium alloy or polymer concrete, they are well suited to use in high traffic areas. Hinged covers allow easy access for inspection or testing.

Part Number	Material	Dimensions	Entry Holes	Load Rating
ERB1	Aluminium	138 x 144 x 74mm	2 x 19mm	5000kg
ERB3	Polymer Concrete	220 x 220 x 150	1 x 40mm	Pedestrian
ERBP3	Plastic	300 x 300 x 207	1 x 70mm	5000kg



ERB1- Aluminium Alloy Casting



ERB3 - Polymer Concrete



ERBP3 - Plastic

## Earthing Enhancement Compounds

### Features

Stable, high conductivity providing long term low ground resistance. High expansion, low shrink characteristics. Non-toxic, non-corrosive.

### Packaging

20kg non-tear, plastic lined bags.

### Installation

1. Apply as a dry mix or pourable slurry.
2. Dry mix will yield a volume of approximately 0.0176m<sup>3</sup> (roughly 57 bags to the cubic metre).
3. Slurry will yield a volume of approximately 0.030m<sup>3</sup> when mixed with 20 to 25 litres of water (roughly 33 bags to the cubic metre).



Type GRC5



Clamp 210

## Earth Rod Clamps

### Single Conductor – Parallel

The Pinch and U-Bolt clamps are simple, robust and have a 'V' groove in the casting to accommodate the earthing cable.

**Material:** Copper alloy casting, bronze set screw or stainless steel U-Bolt and nuts.

### Single Conductor – Parallel (continued)

Part Number	Pack Quantity	Rod Diameter mm	Conductor Size	
			CSA mm <sup>2</sup>	Diameter mm
GRC5	100	13 - 15	10 - 35	4.05 - 7.65
CLAMP 210	10/50	13 - 15	16 - 120	5.10 - 14.21
EPI	40	17 - 19	16 - 120	5.10 - 14.21

### Single Conductor – Versatile

The clamps are designed for either parallel or right angle connections.

**Material:** High copper content alloy castings with stainless steel U-Bolt, spring washers and nuts.

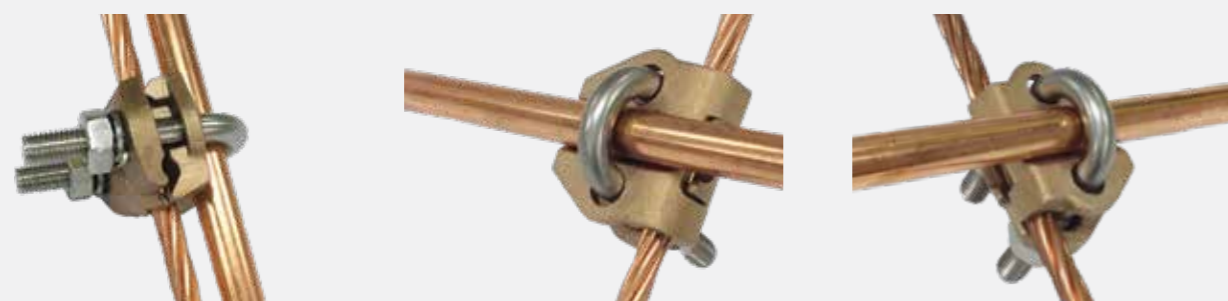

Parallel Connection

Right Angle Connection

Right Angle Connection



Type GB1



Type GB2

Part Number	Pack Quantity	Rod Diameter mm	Conductor Size	
			CSA mm <sup>2</sup>	Diameter mm
GB1	25	13 - 19	16 - 35	5.1 - 7.7
GB2	20	13 - 19	50 - 120	8.9 - 14.2
GB3	10	13 - 19	150 - 185	15.7 - 17.6
EL21090	10	12 - 15	35 - 120	7.6 - 14.2

### Multiple conductor installations for multi-conductor earthing

For two earth conductors parallel to rod or two or three earth conductors at right angles to rod.

**Material:** High copper content alloy castings with stainless steel U-Bolt, spring washers and nuts.

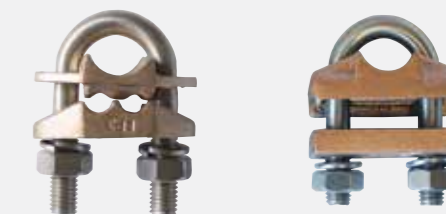

Type EP3

Type ET1

### Earth Rod Clamp Configurations

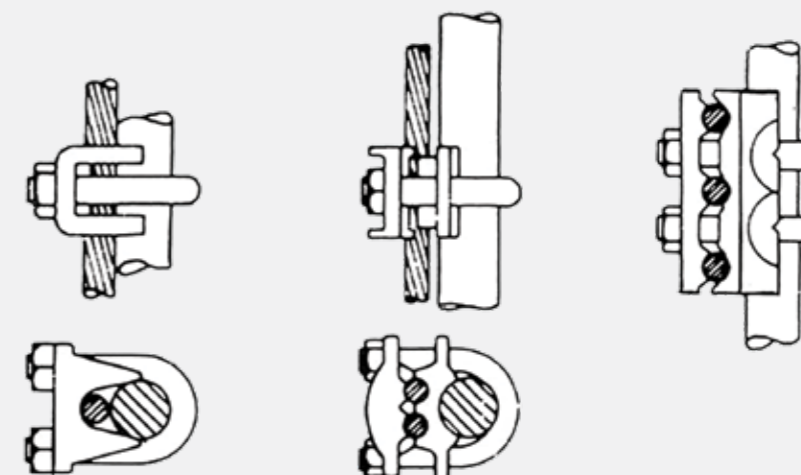

Image No. 1

Image No. 2

Image No. 3

### Earth Rod Clamp Configurations (continued)

Part Number	Pack Quantity	Rod	Conductor Size		No. of Conductors	Image No.
			CSA mm <sup>2</sup>	Diameter mm		
EP3	20	13 - 19	16 - 35	5.1 - 7.7	2	1
EP4	20	13 - 19	50 - 120	8.9 - 14.2	2	1
ET1	25	13 - 19	16 - 35	5.1 - 7.7	2	2
ET2	15	13 - 19	50 - 120	8.9 - 14.2	2	2
ET4	10	13 - 19	50 - 120	8.9 - 14.2	3	3

### Earth Mat Table

Part Number	Material	Size mm	Mesh Size mm
Earthmat	Galvanised Steel	1500 x 900	75 x 60
Earthmat-1	Galvanised Steel	2500 x 1200	75 x 50 x 5
Earthmat-2	Galvanised Steel	2500 x 1000	75 x 50 x 5
Earthmat-3	Galvanised Steel	1500 x 1000	75 x 50 x 5
Earthmat-4	Galvanised Steel	1800 x 1200	75 x 50 x 5

**Note:** Other sizes are available, please contact PLP.

KITY	Installation kit for type RDB rotary switches with earth switch.
------	--

### Earth Mats and Installation Kits

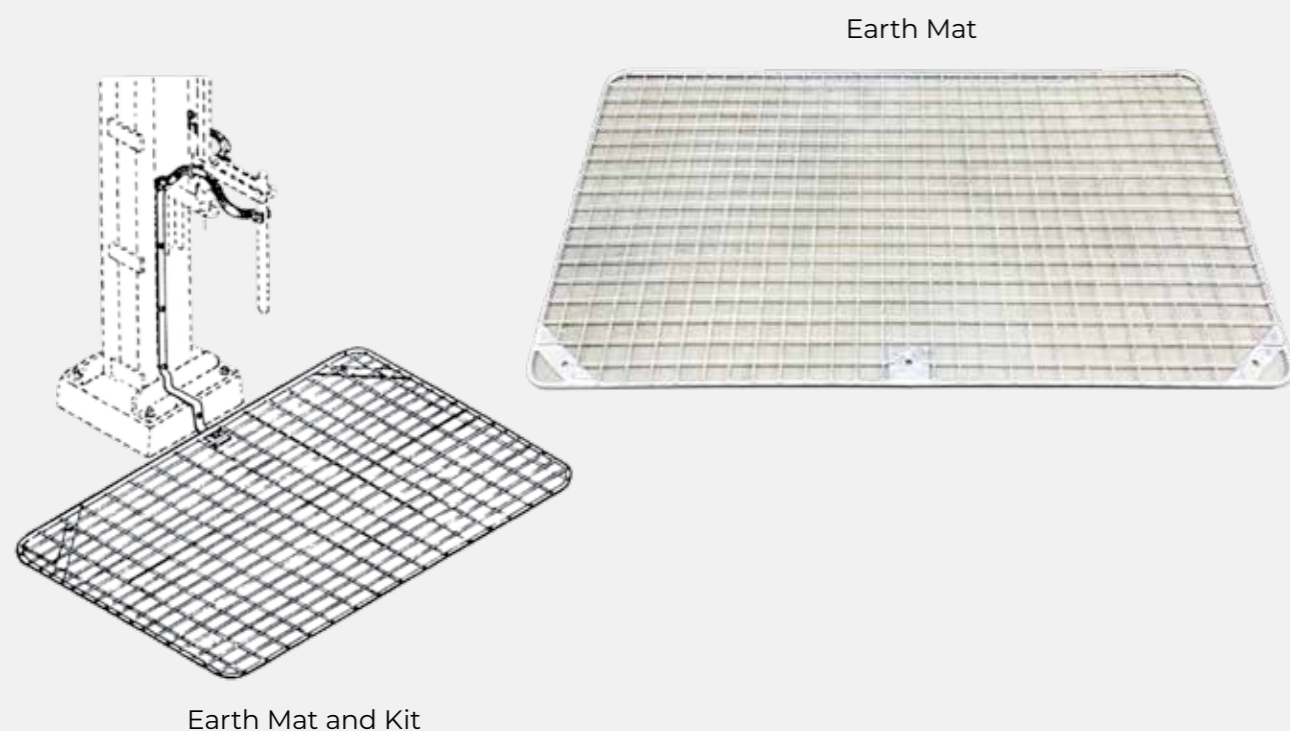

Earth Mat and Kit



Earth Mat and Kit

## Earthing Bond

For commercial earthing installations

The Earthing Bond system provides an earth connection welded to the steel reinforcement, providing a stable and low resistance path to earth.



Earthing Bond

Earthing Bond on Ribar

### Earth Bond Assembly Table

Part Number	Bonding Conductor mm <sup>2</sup>	Length of Bonding Conductor	Lug Diameter	Fault Rating kA for 1 Sec	Terminal Thread and Depth
C70-*	70	3m	Ø12mm	5	M10 x 20mm
C70-1-*	70	1m	Ø12mm	5	M10 x 20mm
C95-*	95	3m	Ø16mm	8.5	M10 x 20mm
C95-1-*	95	1m	Ø16mm	8.5	M10 x 20mm
C120-*	120	3m	Ø20mm	10.5	M10 x 20mm
C120-1-*	120	1m	Ø20mm	10.5	M10 x 20mm

\* Add -12 for 12mm terminal thread

## Additional Products - Tower Bond

For bonding copper cables or wires to steel structures

**Material:** High Grade Copper Alloy, Bolt: Stainless Steel – SS304

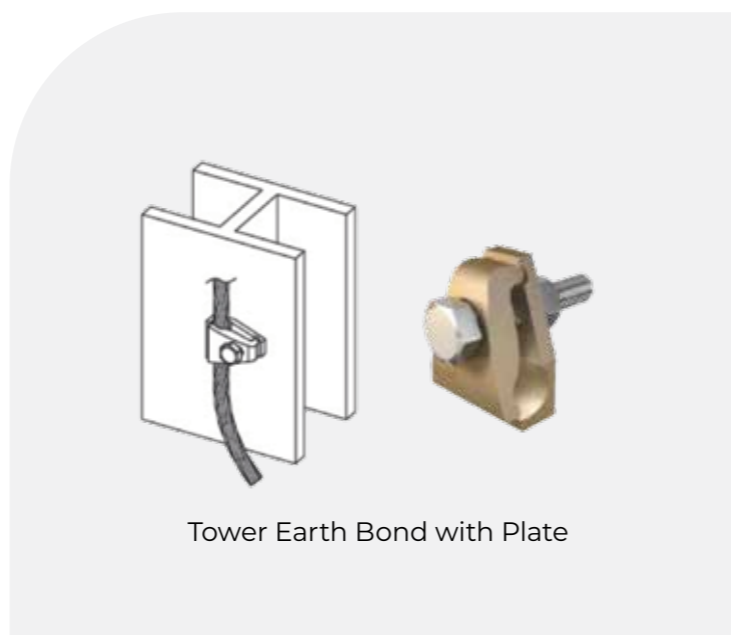

Tower Earth Bond with Plate

## Tower Bond Table

Conductor Range mm <sup>2</sup>	Channel Thickness mm	Bolt Size	Part Number
16 – 35	10	M10	TEB1635
50 – 70	10	M10	TEB5070
95 – 120	10	M10	TEB95120
185 – 240	10	M10	TEB185240

## Copper Clad Steel Wire Conductor

Copper Clad Steel (CCS) wire conductor comprises strands of single copper clad steel wire.

CCS has the strength of steel and the conductivity and corrosion resistance of copper. Other advantages include low density and low cost.

The copper clad steel conductor is an excellent replacement for traditional pure copper wire and there is also less theft as the copper cannot be recovered by scrap dealers.

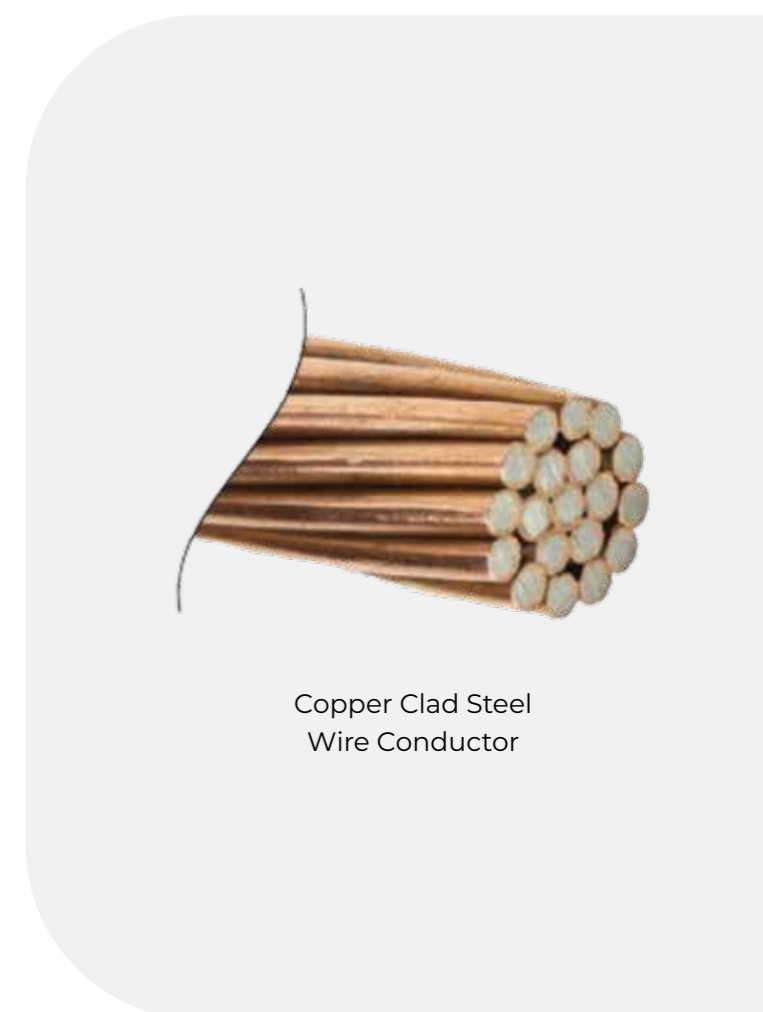

Copper Clad Steel Wire Conductor

## Advantages of Copper Clad Steel Conductors

- Higher tensile strength than pure copper wire conductor
- 13% lighter than pure copper wire conductor
- Less expensive than pure copper wire conductor
- Reduced incidence of copper theft
- Reduced production costs while ensuring the same quality wire.

## Copper Clad Steel Stranded Conductor Table

Part Number	CSA mm <sup>2</sup>	Stranding	Overall Diameter	Weight (kg/km)
SC/CU-070-19	70mm <sup>2</sup>	19/2.14mm	10.60 mm	550
SC/CU-095-19	95mm <sup>2</sup>	19/2.52mm	12.60 mm	766
SC/CU-120-19	120mm <sup>2</sup>	19/2.84mm	14.00 mm	980

## Earth Stubs

### Earth Stubs Table

Part Number	Length	Diameter	A/F	Thread Depth	Thread Size
ESB-M12-1	80mm <sup>2</sup>	25mm	30 A/F	40mm	M12
ESB-M16-120	120mm <sup>2</sup>	25mm	30 A/F	50mm	M16

Other custom versions are available upon request.



Brass Earth Stubs

## CEC Connectors

**A heavy duty compression connector for earth rods and conductors.**

PLP CEC connectors were specifically developed to dissipate surges of high fault current quickly and effectively to limit any potential damage to equipment, and to safeguard personnel close

to that equipment.

Manufactured from pure wrought copper, the CEC connector is fitted by use of standard compression tools to form a dependable, tamper-proof joint from conductor to earth rod or buried earthing cable.

## Earthing Grid Applications

By joining two Compression Connectors with the same or different part numbers, various combinations of conductor size and grid connections are possible. This enables a quick and economical assembly.

## Features and Benefits

**Simple installation** – one crimp from a standard compression tool.

**Connector design** – current carrying capacity greater than that of the conductor.

**Corrosion resistant** - identical material to the conductor eliminates problems caused by electrolytic corrosion and the corrosive effects to some soil.



CEC 6



CEC070



CEC095



## Features and Benefits

### Pre-coated with Coppalube –

a specially formulated jointing compound heavily laden with copper particles, to increase the mechanical and electrical integrity of the connection, exclude moisture and resist rotation of the connector on the earth rod

**All weather application** – this connector may be installed in damp or fire risk areas with no adverse effects on the joint or the environment

**Easy identification** – each CEC connector is clearly stamped with the appropriate catalogue number, conductor size and installation die reference

**Individually packed** – for cleanliness and ease of handling.

## Installation Notes

- Standard “C” head compression tool of minimum 12 tonne capacity recommended
- Full compressive force of the tool is utilised as application is not limited by die halves meeting,
- but the pressure release valve in the tool.
- Regular use of a load test cell to check compression performance of the tool is recommended.

## CEC Connector Table

Part Number	Conductor Combination mm <sup>2</sup>		Die Set Part Number	Profile
CEC070	35	35	DUOT	C
	50	35	DUOT	C
	50	50	DUOT	C
	70	50	DUOT	C
CEC095	70	70	DUOT	C
	70	95	DU1315	C
CEC120	95	95	DU1315	C
	120	70	DU1315	C
CEC120	95	120	DU1315	C
	120w	120	DU1315	C

Part Number	Open Section	Tap Conductor Diameter mm	Tap Conductor mm <sup>2</sup>	Profile
CEC15035	Conductors 50-120mm <sup>2</sup> OR Earth	8.4	25-40	6
CEC15070		11	50-70	6
CEC15120	Rods 13- 15mm dia	15	95-120	6
CEC15150		16.5	120-150	6

Die Set Part Number for “6 Profile” is DU1315

## Exothermic Welding Connection

Exothermic connections are the best bond for copper and steel as they provide an irreversible molecular bond that is far superior to any other type of connection.

Although the temperatures reached to achieve this weld are extremely high, the process is instant when compared to brazing, soldering and all types of mechanical connections.

### Exothermic connections provide

- Permanent connection, unaltered throughout the facility's lifetime
- A cross-sectional area that in most cases is twice that of the conductors
- A connection without contact pressures that tend to loosen and corrode over time

- High electrical current, equal to or higher than the conductors. On short-circuit tests, the conductors melt before the exothermic connection
- Capability to withstand repeated high electrical currents without any wear or erosion
- Quick and easy visual inspection

Exothermic connections are suitable for welding copper to:

- Mild steel
- Stainless steel
- Copper clad steel
- Galvanised steel
- Copper
- Bronze
- Brass
- Monel Metal

PLP supplies the **Apliweld® Secure+** exothermic system that uses a unique tablet format compound for every weld type, eliminating the traditional multiple powders required for different welds.

This unique tablet format also eliminates all explosive and flammable materials, whilst the robust electronic ignition with remote Bluetooth activation offers the user the safest exothermic welding system on the market.

**Apliweld® Secure+** is the safe, versatile and reliable exothermic system for:

- Electrical systems earthing
- Busbar connections
- Energy transport and communications
- Industrial equipment earthing

**Apliweld® Secure+** exothermic connections are:

- Self-contained
- Use zero flammable and explosive materials
- Does not require flammable and explosive
- gas cylinders
- Does not require external power source

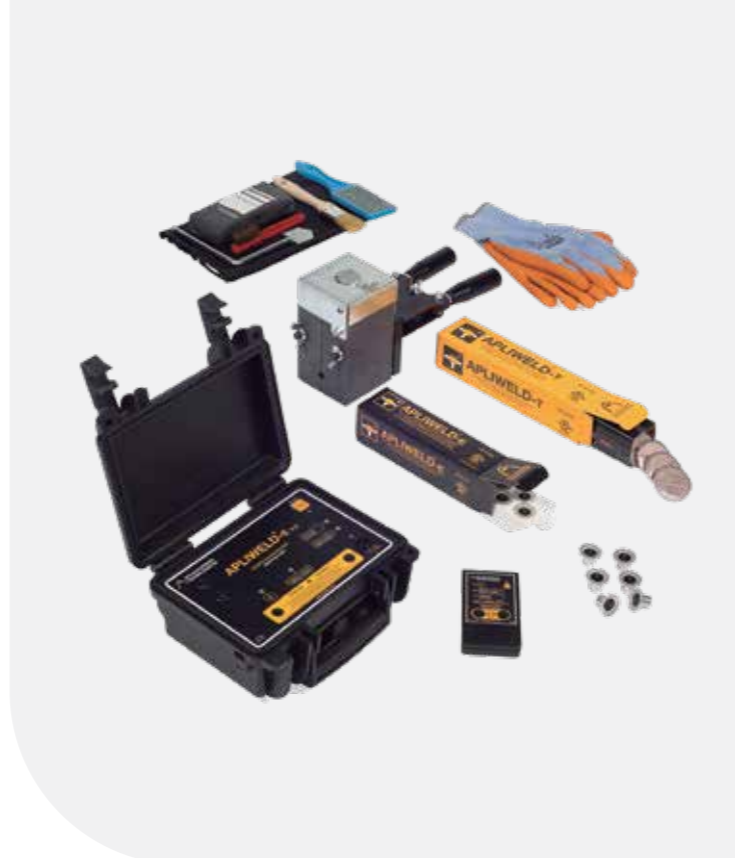

Illustrated below are various types of connections used in earthing systems above and below ground. Contact PLP for more information.

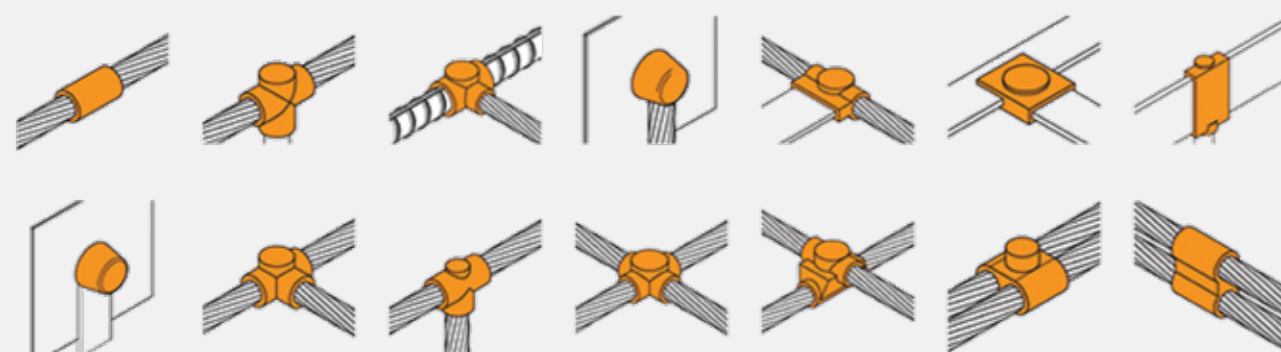

## Airport Earthing Terminal

### Static electricity earthing terminals

The standard length is 1800mm, other lengths are available via special order.

Type AET electrodes provide for the earthing of airport tarmac areas where any generation of static electricity could be hazardous, i.e. aircraft refuelling, servicing and cargo loading areas. The heavy duty capping has a ribbed design affording a fast and positive earthing connection by means of earth lead connector clips.

**Material:** Solid steel core overlaid with copper bonding and a heavy bronze cap.

**Installation Procedure:** Drive electrode into ground to required depth. Remove protruding portion of rod above cap and finish flush.

## Methods of Installing Earth Rods

Earth rods are installed by one of two methods. The rod can be driven into the ground by either a hand held hammer or mechanically operated hammer. However, where driving is difficult the only option is to drill a hole to take the earth rod.

Where holes are drilled, the gap between the earth rod and wall of the



Part Number: AET1918 (Surface)



Part Number: AET1918F (Flush)

drilled hole is commonly filled with a water expanding compound such as EARTHRITE. This is a mixture of Bentonite and Gypsum with a small amount of Sodium Sulphate to reduce the resistivity of the backfill.

### Driving Methods

Earth rods up to 3m long can be driven satisfactorily in one length. Where rods have to be longer than 3m, it is preferable to use one of the PLP extendable series earth rods.

There are a variety of methods for driving earth rods into the ground from the simple hand held hammer to power operated mobile rigs. Their use is dictated by the nature of the soil and terrain, the length of drive needed to

secure minimum resistance, and the number of rods to be driven.

The Hand Held Hammer is an effective method for most domestic installations. The earth rod should be driven lightly using a hammer of around 1.5 to 3 kgs, keeping the force of the blows axial to the rod to obviate the risk of whipping.

A large number of comparatively light hammer blows are more effective, and preferable, to heavy blows which are destructive to the metal and can cause deformation to the rod end as well as bending and possible splitting. The fitting of a guide to the rod will assist rigidity and reduce whipping when the rod comes up against resistance to penetration.

The Mechanical Hammer can be one of three types, electric, pneumatic or petrol engine driven. These power operated aids are used when soil

conditions are not suited to hand driving and when long earth rods have to be driven to great depths.

### Driving Method Precautions

Driving an earth rod with a mechanical hammer calls for special care to ensure the force of the blows are axial to the rod. While it may be possible to maintain this when manually using a light type hammer such as an electric Kanga, it is certainly advisable to use rig mounting to ensure correct driving especially when it comes to driving the longer earth rods.

Very light and very heavy hammers with a long stroke are not suited for earth rod driving. Medium tools in the 7.5 to 12 kgs range with a stroke of approximately 58 to 108mm delivering 2200 blows per minute are ideal for normal applications.



Mechanical Hammer



**PLP Australia**

190 Power Street,  
Glendenning NSW 2761

P : 1300 550 322

E : [sales@plp.com](mailto:sales@plp.com)

[www.plp.com/au](http://www.plp.com/au)